

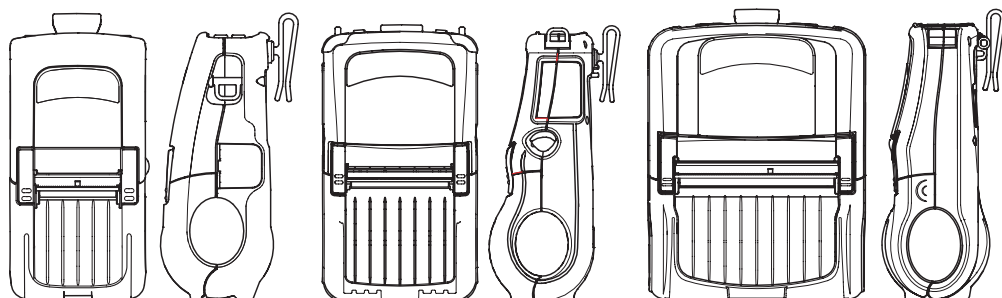

Introduction

Thank you for choosing one of our Zebra QL Plus Series™ Mobile Printers. These rugged printers will become productive and efficient additions to your workplace thanks to their innovative design. Because they are made by Zebra Technologies you can be assured of world-class support for all of your bar code printers, software, and supplies.



QL220 Plus	QL 320 Plus	QL 420 Plus
Media width: .75 in. to 2.12 in. (16 to 53.8 mm)	Media width: 1.5 in. to 3.1 in. (38.1 to 78.4 mm)	Media width: 2 in. to 4.1 in. (50.8 to 104.1 mm)
L: 7.52 in. [191.0 mm]* W: 3.57 in. [90.7 mm] H: 3.61 in. [91.7 mm]* *w/ belt clip	L: 8.16 in. [207.4 mm]* W: 4.67 in. [118.7 mm] H: 3.9 in [100.2 mm]* *w/ belt clip	L: 8.20 in. [208 mm]* W: 6.1 in. [154.9 mm] H: 3.5 in. [89 mm]* *w/ belt clip

This document provides an easy reference for operating and maintaining the QL Plus Series of Mobile Printers.

Complete and current documentation for each model printer is provided by the QL Plus Series User Guide available on the Internet at: www.zebra.com/manuals.

! Always refer to the Important Safety Information data sheet shipped with each printer and the Technical Bulletin shipped with each battery pack. These documents detail procedures to ensure maximum reliability and safety while using this printer.

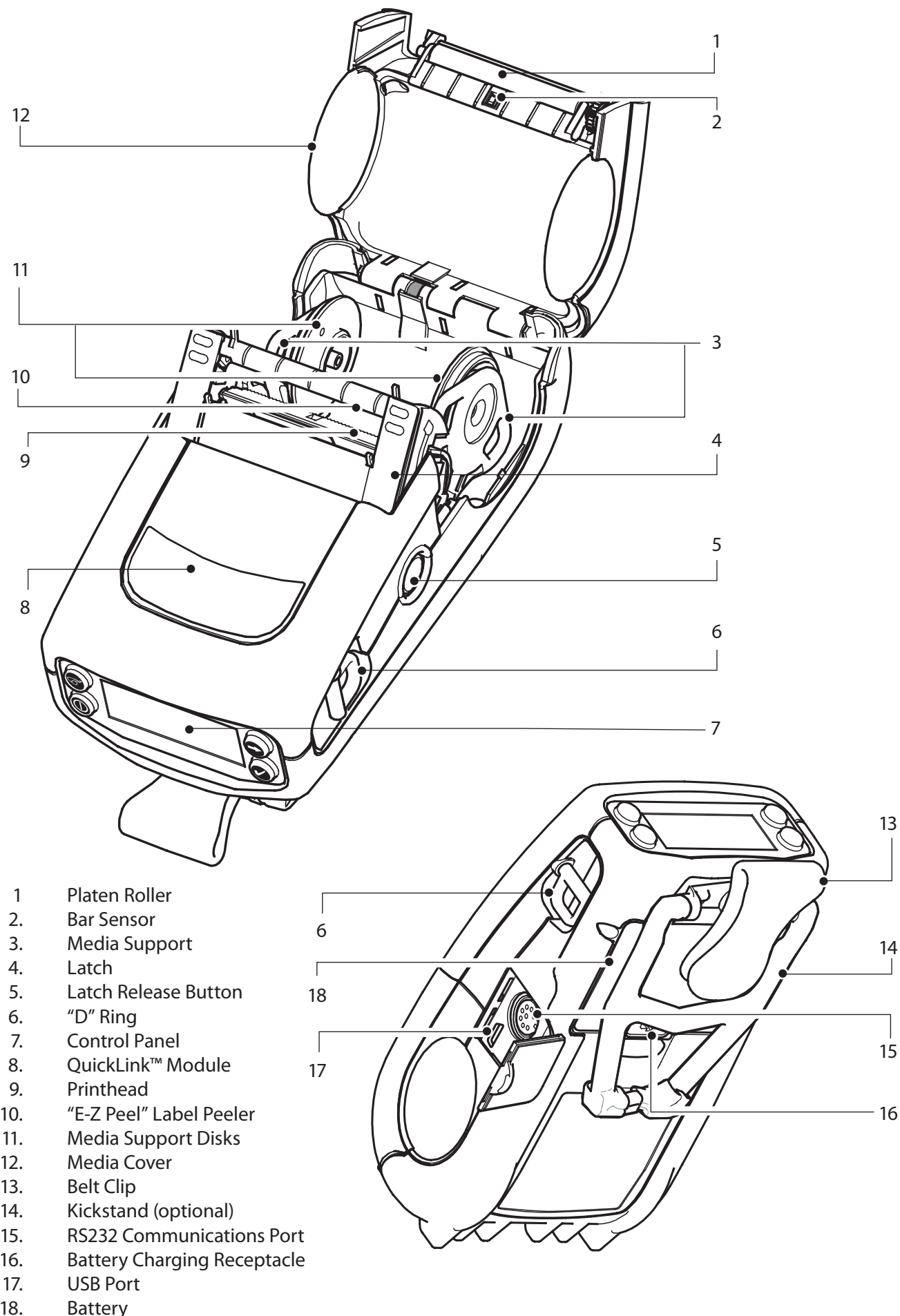

QL Plus Series Overview

(QL 220 Plus Illustrated)



1. Platen Roller
2. Bar Sensor
3. Media Support
4. Latch
5. Latch Release Button
6. "D" Ring
7. Control Panel
8. QuickLink™ Module
9. Printhead
10. "E-Z Peel" Label Peeler
11. Media Support Disks
12. Media Cover
13. Belt Clip
14. Kickstand (optional)
15. RS232 Communications Port
16. Battery Charging Receptacle
17. USB Port
18. Battery

Charge the Battery

-  Batteries are shipped uncharged. Remove protective shrink-wrap and labels from new battery packs and allow them to charge completely prior to initial use.
-  Do not charge the battery while using the printer!
Charge the battery pack when removed from the Printer for best results.

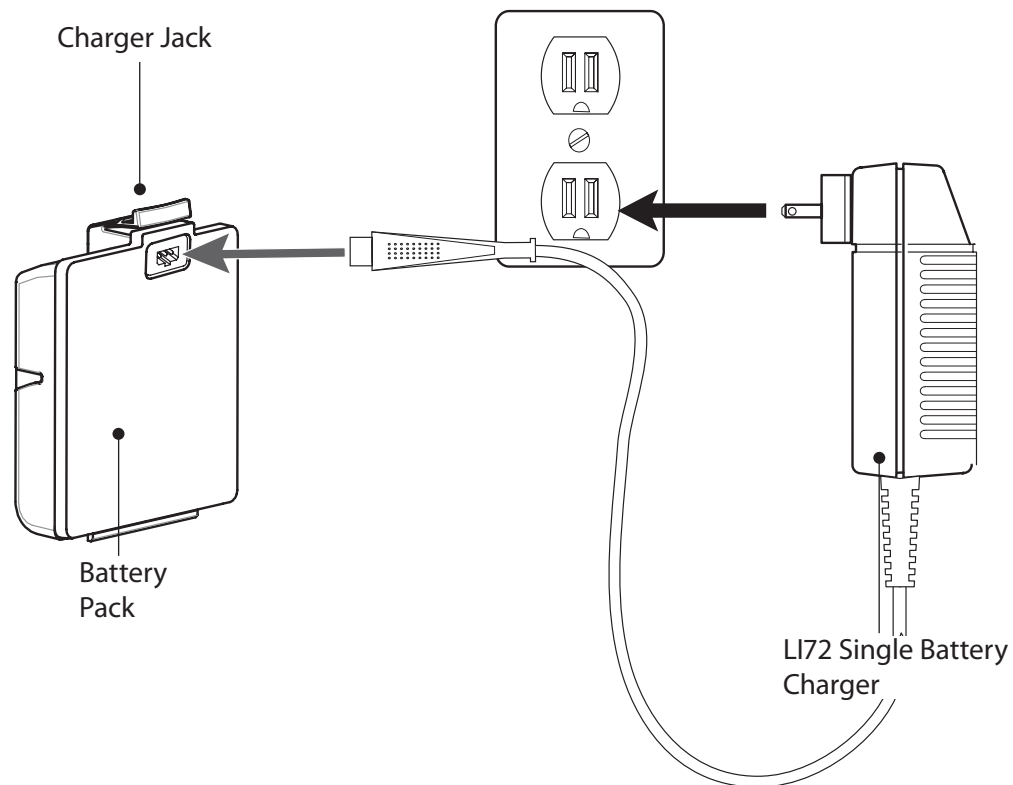

Using the LI72 Single Charger

Insert the plug from the charger cable into the battery pack's charger jack. Plug the charger into the A.C. outlet. The light on the front of the charger will indicate the battery pack's charge status.

Consult the QL Plus User's Guide available at www.zebra.com/manuals for complete information on using the various versions of the Model LI72 Single Charger.

Install the Battery

Rotate the Belt Clip out of the way of the Battery

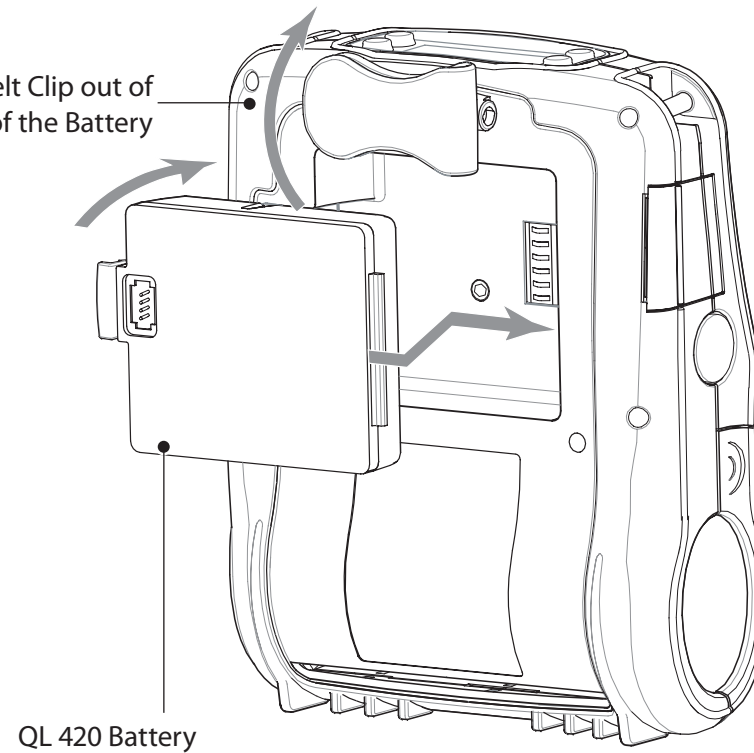

Rotate the Belt Clip out of the way of the Battery

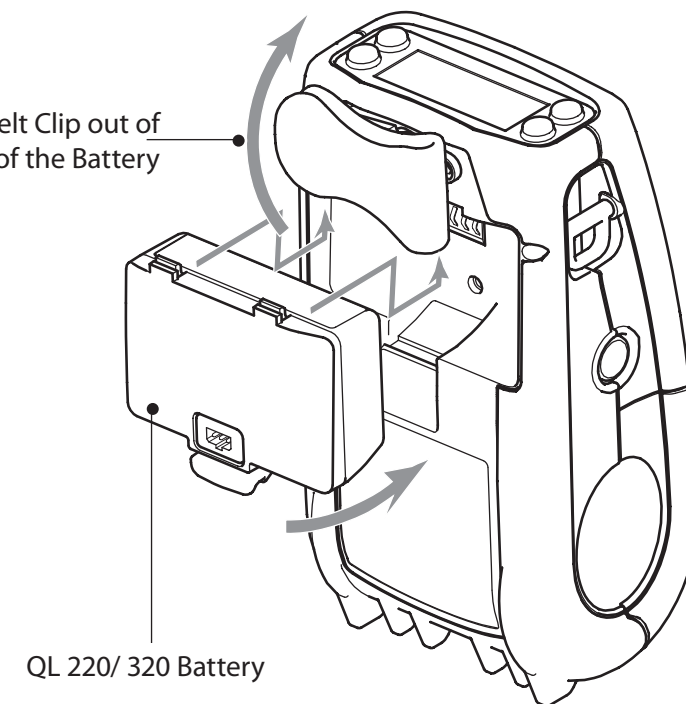

Load the Media

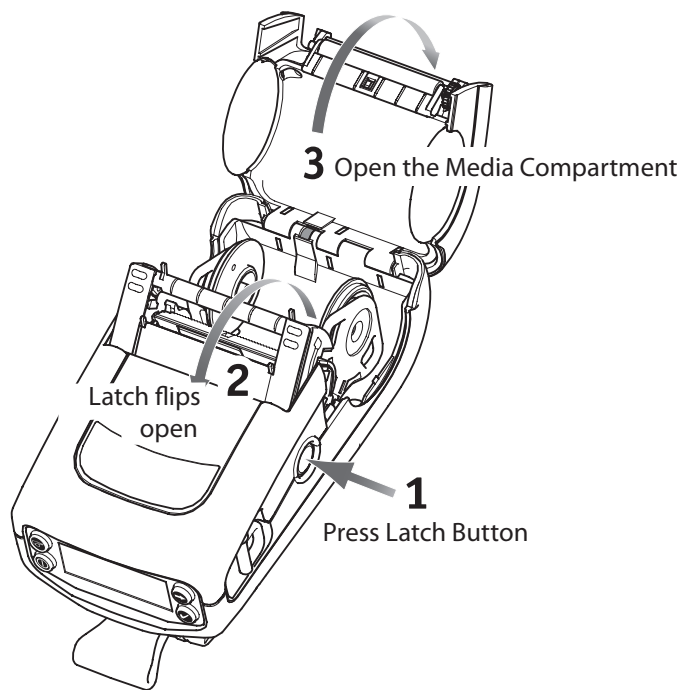

Open the QL 220 & 420

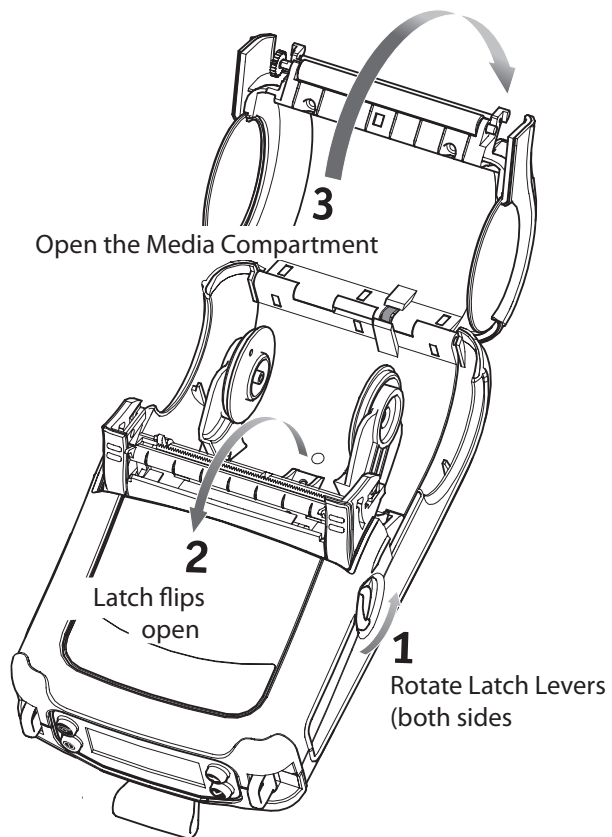

Open the QL 320

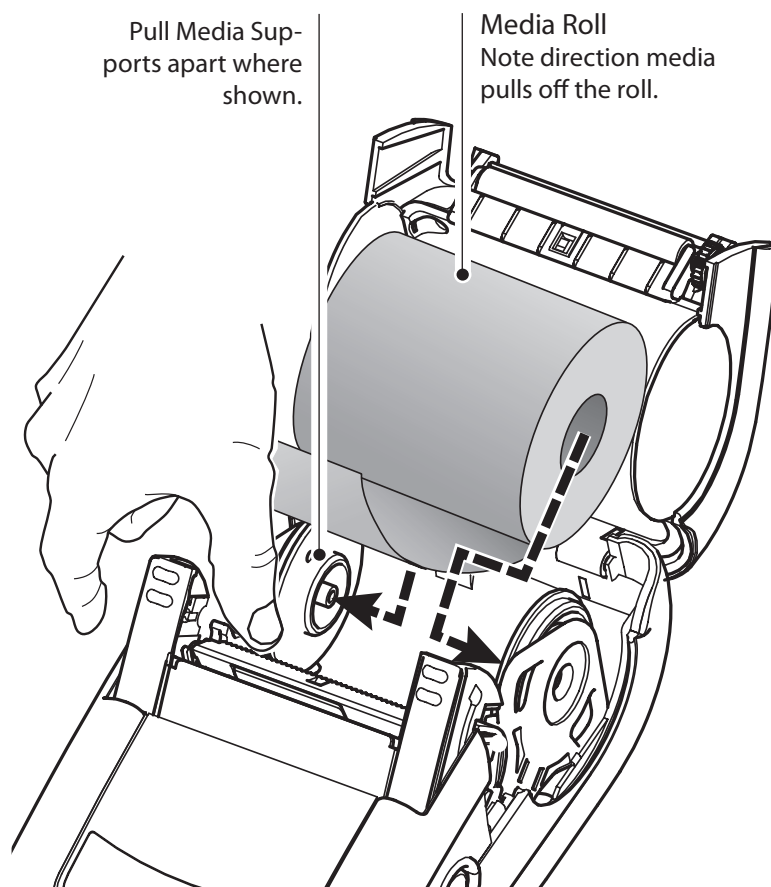

Load the Media Roll
(common for all models)

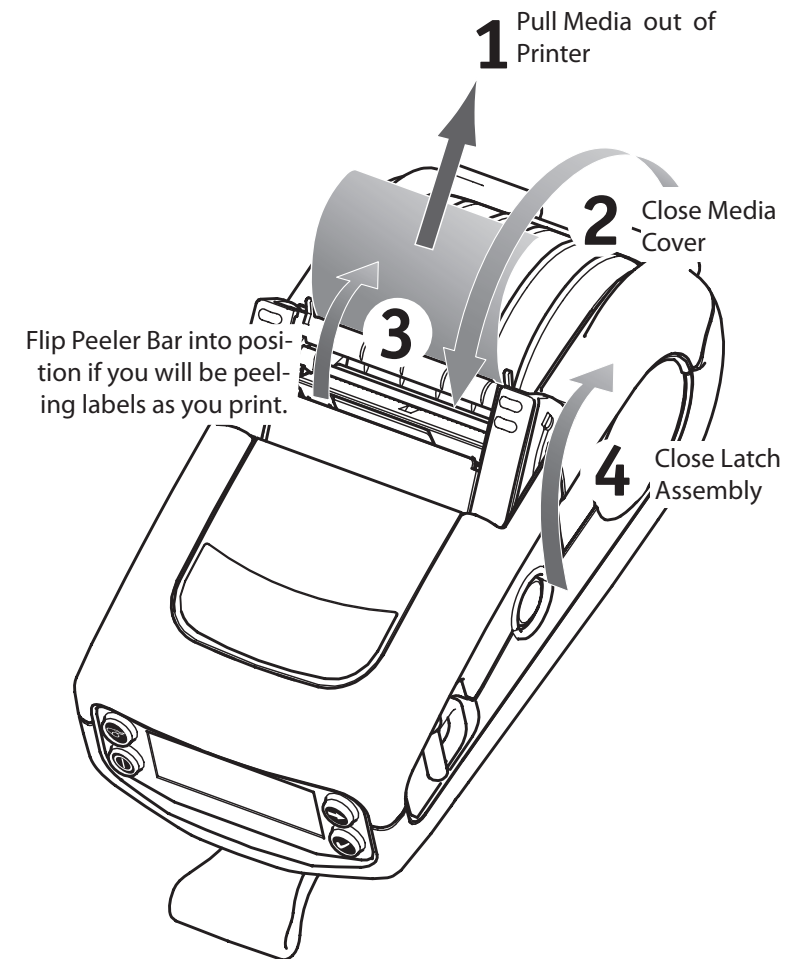

Close the Cover
(common for all models)

Connect the Printer

Connect The Printer With a Cable

You can connect your printer to a terminal or a PC using either RS232C or USB protocols. Refer to the Label Vista™ application available on the QL product CD or at www.zebra.com/software for help on setting up communications with your printer.

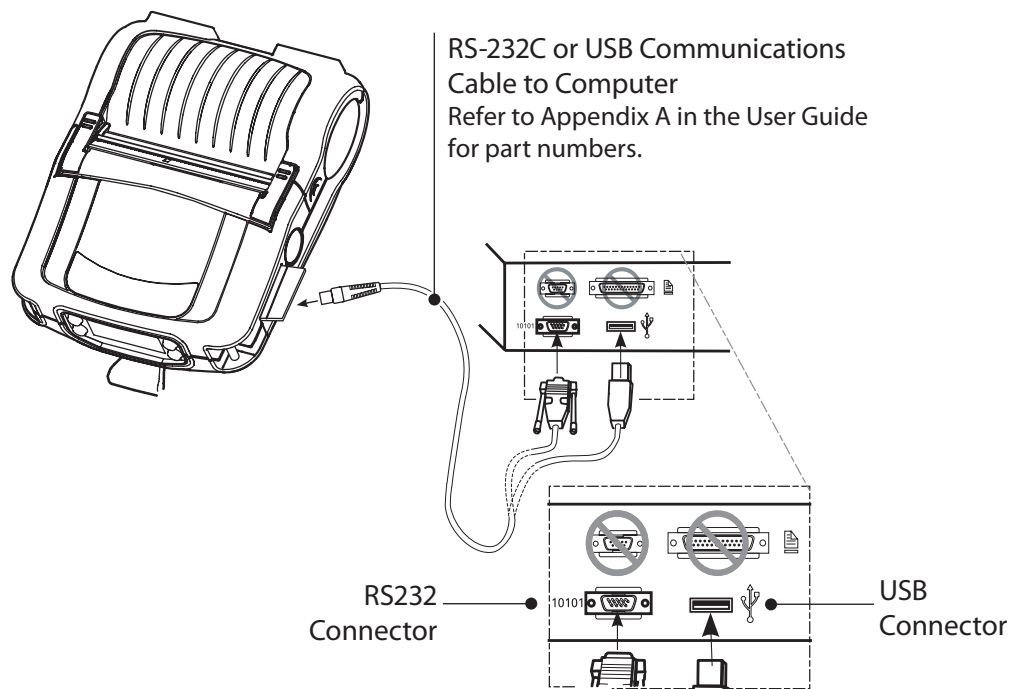
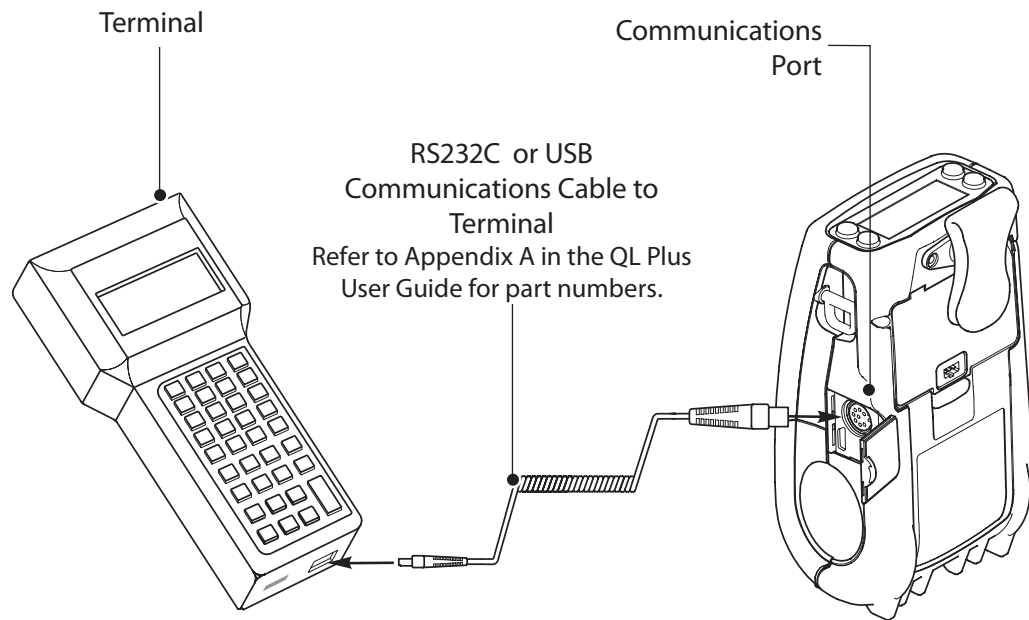

Connect the Printer by Infrared (IR) or Radio

If your QL Plus printer has the optional IR module, you can make wireless line-of-sight connections to other IR equipped devices using the standard IrDA protocol.

If your QL Plus printer has a radio option, you can connect wirelessly to either a terminal or a wireless network (WLAN.) Refer to the Mobile Printer Wireless Configuration Guide available on the product CD or at www.zebra.com/manuals for help on setting up wireless communications with your printer.

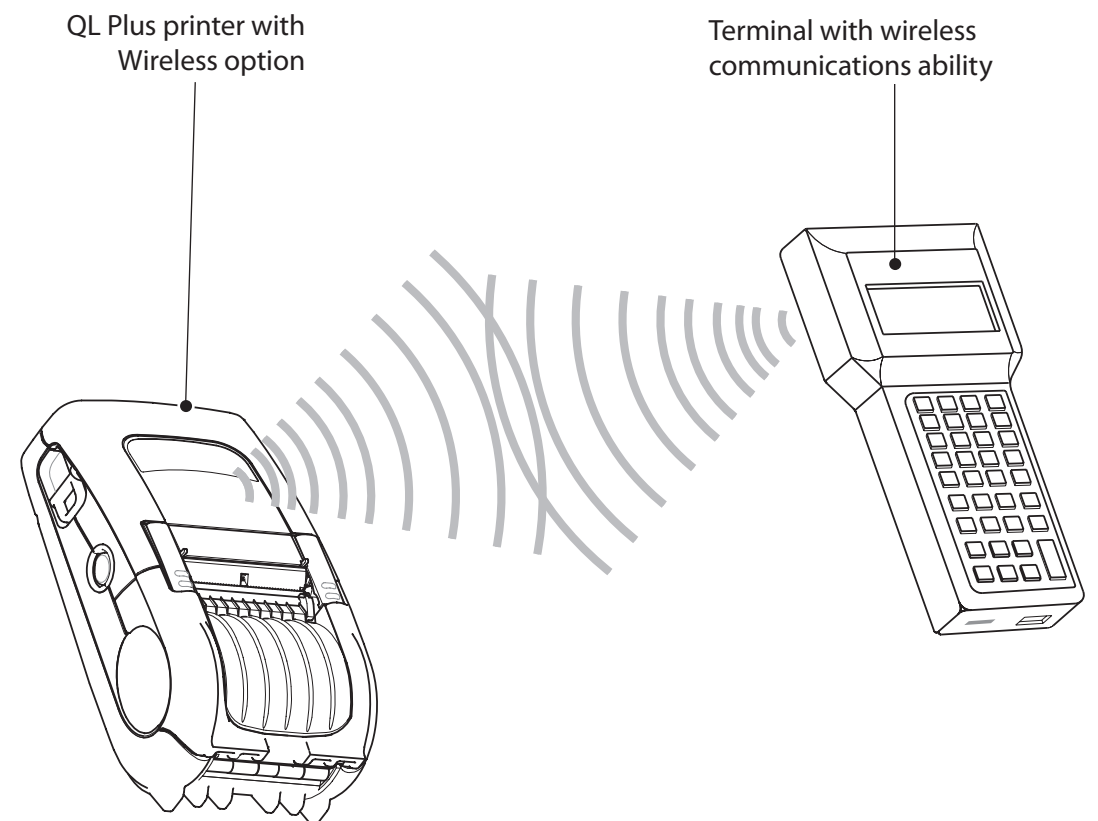

Printer Controls

Standard Keypad

Refer to the QL Plus User's Guide for complete information.

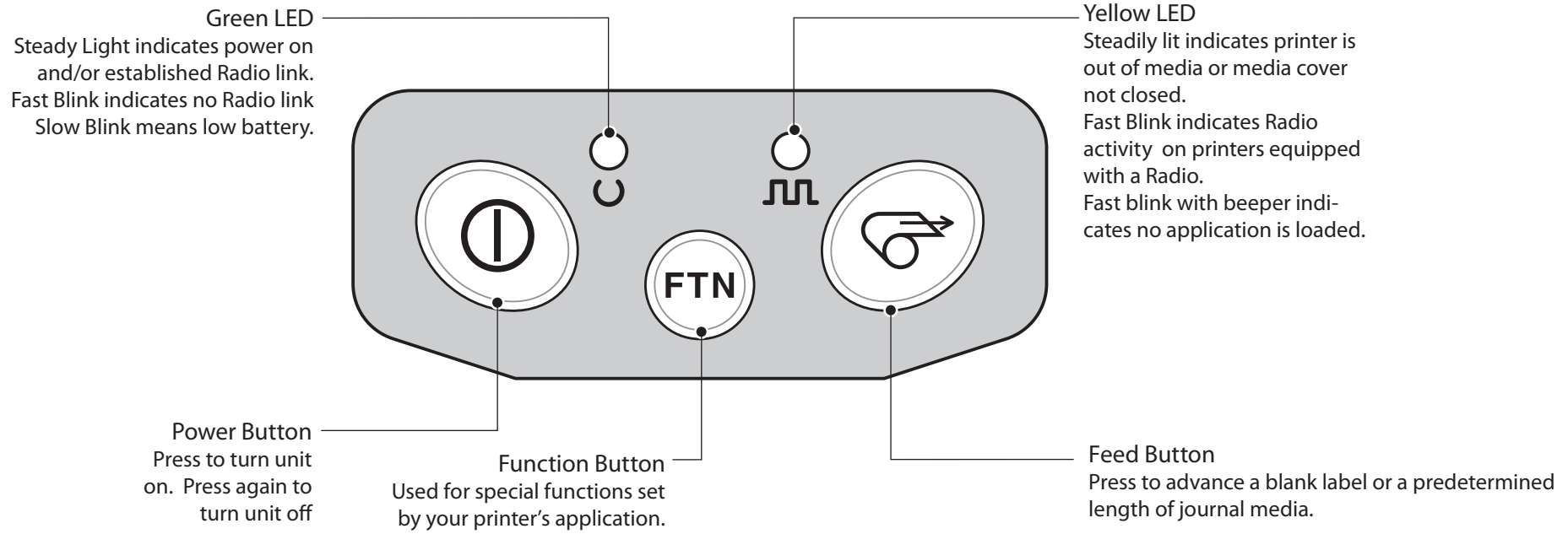

Optional LCD Keypad

Refer to the QL Plus User Guide for complete information.

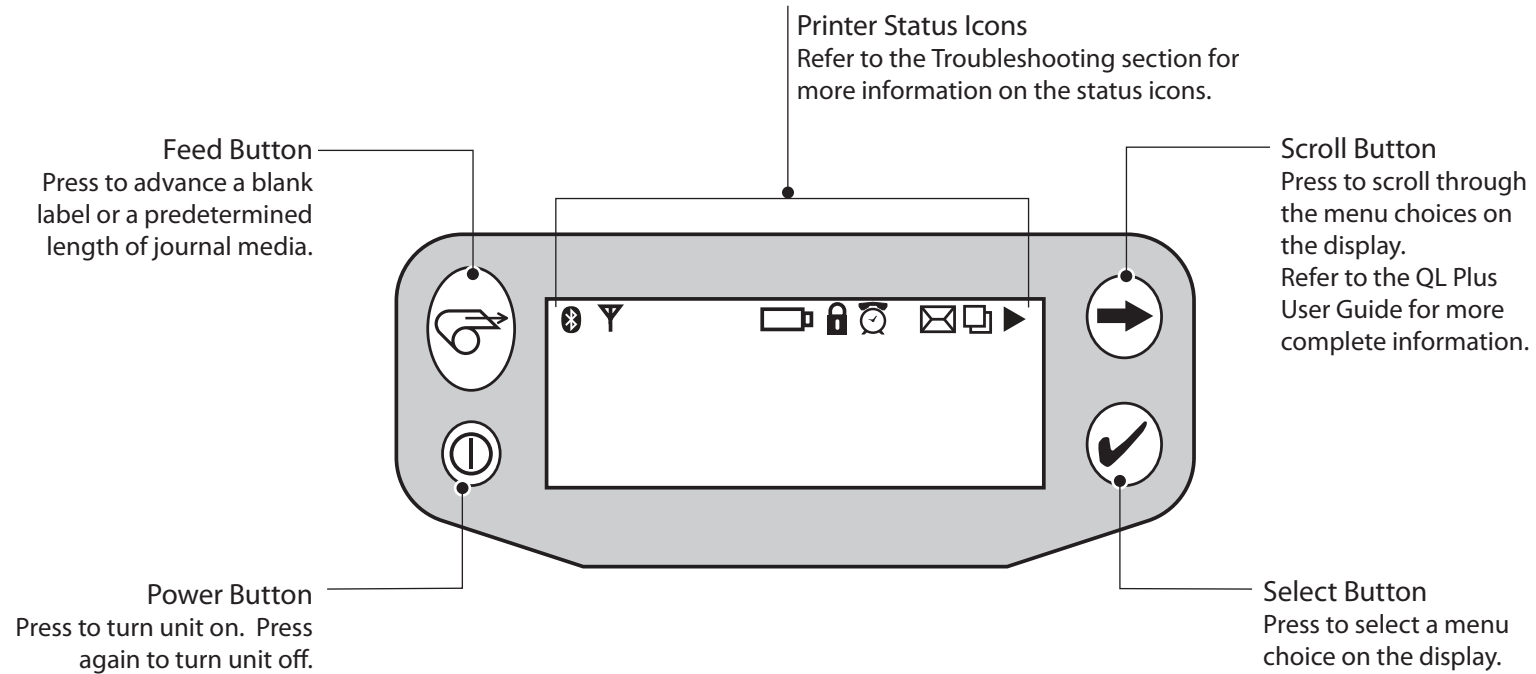

Cleaning the Printers



Caution • To avoid possible personal injury or damage to the printer never insert sharp or pointed objects into the printer mechanism.

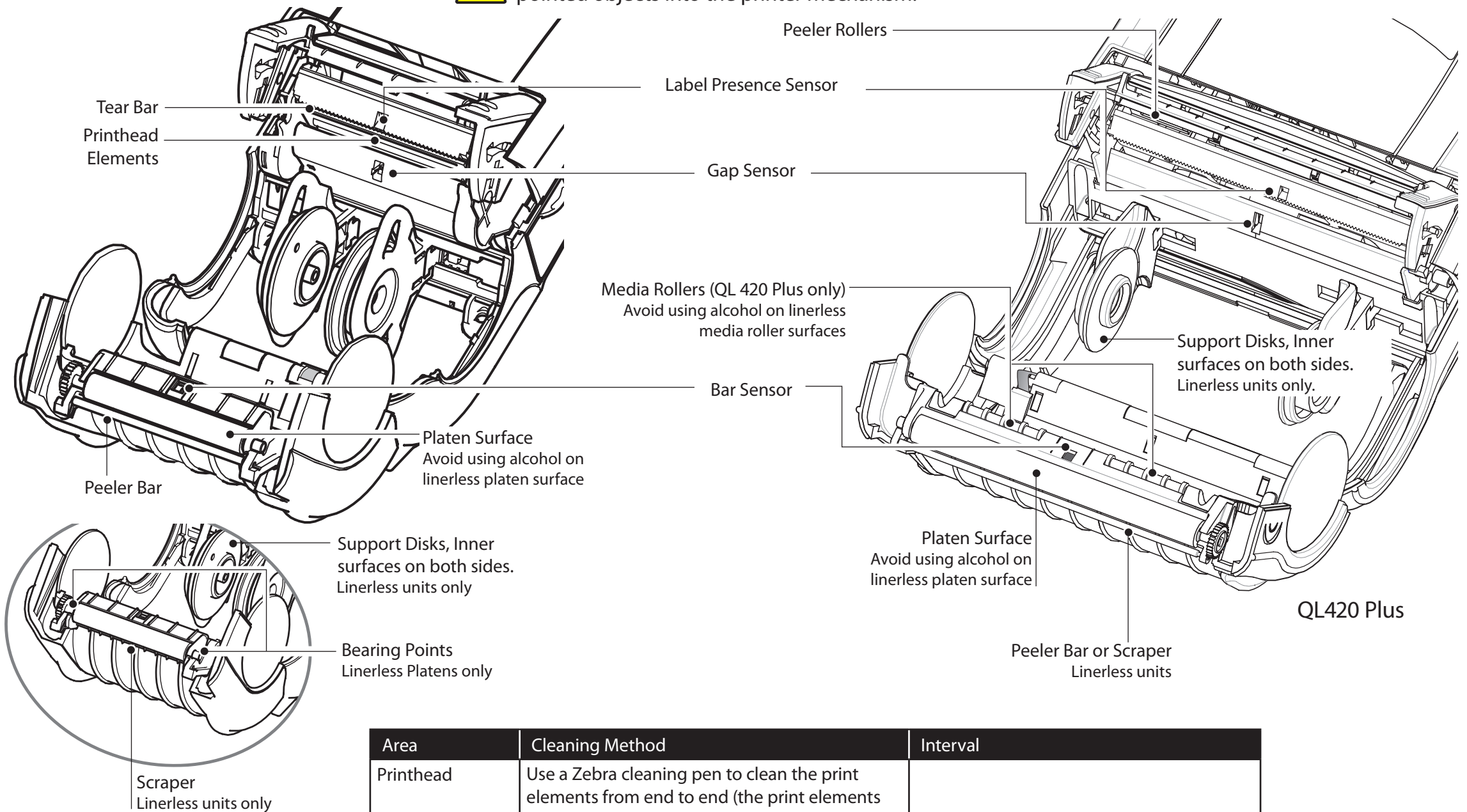

QL220 Plus (shown)
& QL 320 Plus

QL420 Plus

Area	Cleaning Method	Interval
Printhead	Use a Zebra cleaning pen to clean the print elements from end to end (the print elements are located in the thin gray line on the printhead).	After every five rolls of media (or more often, if needed) Linerless media requires more frequent cleaning
Platen Surface	Rotate the platen roller and clean it thoroughly with the cleaning pen.	
Linerless Platen Surface	Units with linerless platens: Rotate platen & clean bearing points only. Avoid use of alcohol on the surface of linerless platens!	As needed
Peel bar	Clean thoroughly with the cleaning pen.	
Scraper (Linerless units only)	Clean thoroughly with the cleaning pen.	After every five rolls of media (or more often, if needed)
Tear bar	Clean thoroughly with the cleaning pen.	As needed
Exterior	Wipe with water-dampened cloth	
Interior	Brush/airblow. Ensure the Bar Sensor, Gap Sensor and Label Present Sensor windows are free of dust.	

Troubleshooting

LCD Control Panel

The top of the display shows icons indicating various printer functions. Check the icon's status and refer to the referenced Troubleshooting topic on the following pages.

Icon	Status	Indication	Ref. to Topic # on next page
	On	Bluetooth Link established	n/a
	Off	No Bluetooth Link	5
	On	Bluetooth link established	n/a
	Off	No Bluetooth link	5
	Flashing	Transmitting/Receiving data	n/a
	On	802.11x RF Link established	n/a
	Off	No 802.11x RF Link	5
	Flashing	Low Battery	3, 5, 6,
	Flashing	Head latch not closed	9, 11
	Flashing	Indicates Printing activity	n/a
	Steady	Data processing in process	7
	Flashing	Out of Media	9,11
	Blank Screen	n/a	No application



QL series printers may be built with one of two LCD types. LCDs using the Bluetooth icon (highlighted by a gray background in the table above) will gradually replace LCDs with the "light bulb" icon indicating Bluetooth activity. Printers with either type of display will function identically.

Standard Control Panel

Refer below to find the state of the two LEDs on the Control Panel. Then refer to the referenced Troubleshooting topic on the following pages.

Green LED Status	Yellow LED Status	Indication	Ref. to Topic #
Steady	Off	Normal Operation and/or RF Link established	n/a
Off	Off	Power Off	1
Fast Blink	Off	No RF Link	5, 10
Slow Blink	Off	Low Battery	3, 5, 6
Steady	Steady	Out of media, or Media Cover not closed	8, 10
Steady	Fast Blink	Normal RF activity	7
Steady	Fast Blink, Beeper	No application	7

Troubleshooting Topics

1. No power:

- Check that battery is installed properly.
- Recharge or replace battery as necessary.

2. Media does not feed:

- Be sure printhead is closed and latched.
- Check media support components for any binding.
- If unit is equipped with label presence sensor, ensure the most recently printed label is removed.
- Ensure label sensor is not blocked.

3. Poor or faded print or icon flashing:

- Clean printhead.
- Check battery. Recharge or replace as necessary.



Always dispose of batteries properly. Refer to Appendix E of the QL Plus User Guide for more information.

- Check quality of media.

4. Partial/missing print:

- Check media alignment.
- Clean printhead.
- Ensure printhead is properly closed and latched.

5. No print:

- Replace battery.
- Check cable to terminal.
- Wireless units only: Restore wireless connection.

6. Reduced battery life:

- Check battery date code. If battery is one to two years old, short life may be due to normal aging.
- Replace battery.

7. Yellow error light or icon flashing:

- Units without a wireless option: No application loaded or application corrupted; program must be reloaded.
- Wireless units only: flashing error light or icon indicates data transmission.

8. Yellow error light always on, or flashing:

- Check that media is loaded and that printhead is closed and securely latched.

9. Skips labels:

- Ensure correct media is being used.
- Ensure bar/ or gap sensor is not blocked.

10. Communication Error:

- Check media is loaded, head is closed and error light is off.
- Replace cable to terminal.

11. Label Jam:

- Open head release latch and media cover.
- Generously apply alcohol using either a Zebra cleaning pen or an alcohol-saturated cotton swab to the area of jammed label.



Caution- Never use sharp or pointed objects when attempting to remove a label jam.

12. Blank LCD Screen:

- No application loaded or application corrupted: program must be reloaded.

Accessories

LI72-4 Quad Charger

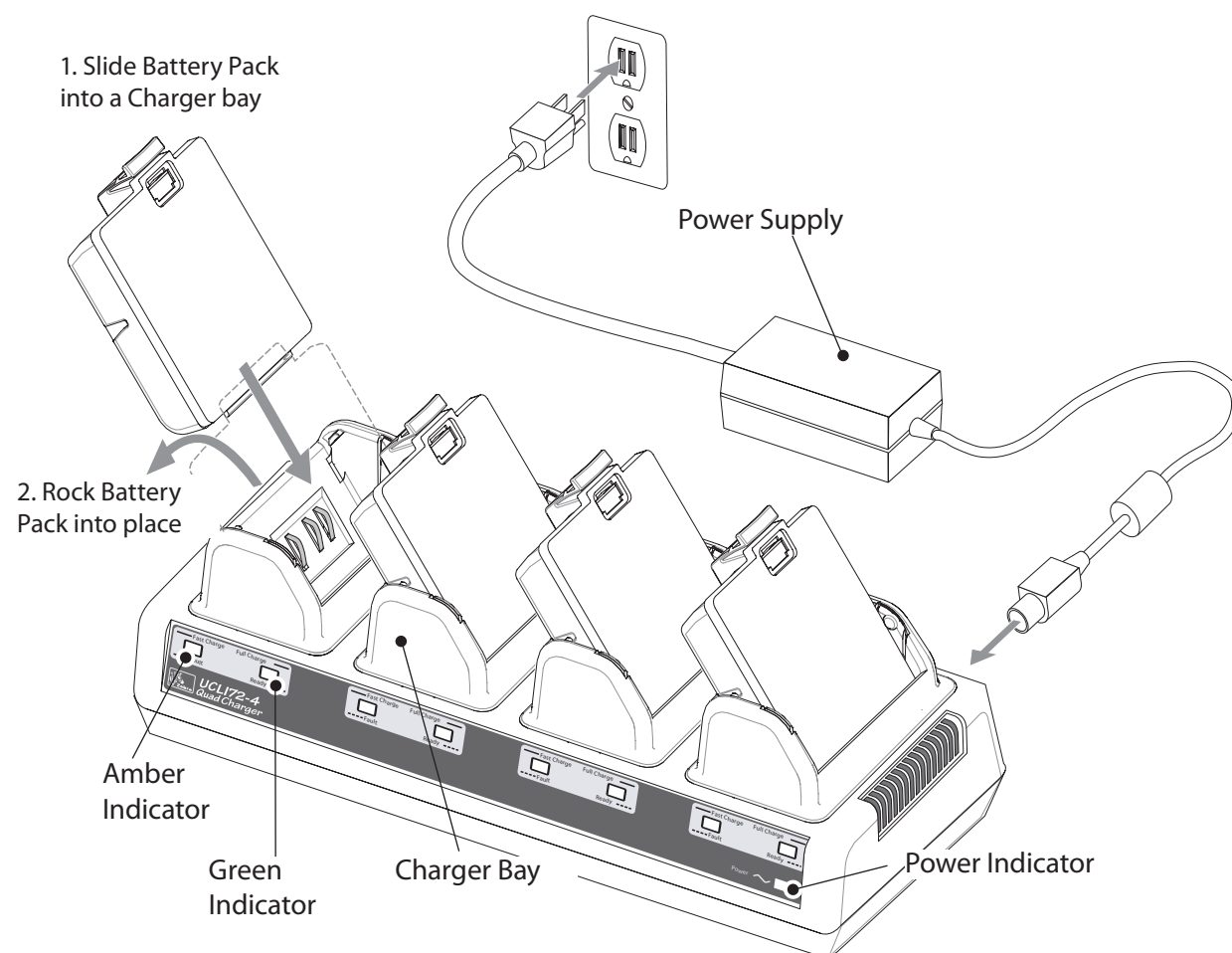

The UCLI72-4 Quad Charger is designed to charge up to four QL series battery packs simultaneously.

Plug a battery pack into any one of the four charging bays as shown opposite, noting the orientation of the battery pack. Slide the battery pack into the charging bay until it stops. Then rock the battery pack back until it snaps into place. The amber indicator directly under the battery being charged will turn on if the battery is properly inserted.

The indicators under the battery will allow you to monitor the charging process per the table below:

Amber	Green	Battery Status
On	Off	Charging
On	Flashing	80% charged (O.K. to use)
Off	On	Completely Charged
Flashing	Off	Fault



Notes: For more information refer to the instructions included with the LI72-4 Quad Charger, or to the more detailed discussion of the quad charger in the QL Plus User Guide.

The UCLI72-4 Quad Charger has a safety feature which stops charging a battery after six hours regardless of its charge state.

Belt Clip (standard on all printers)

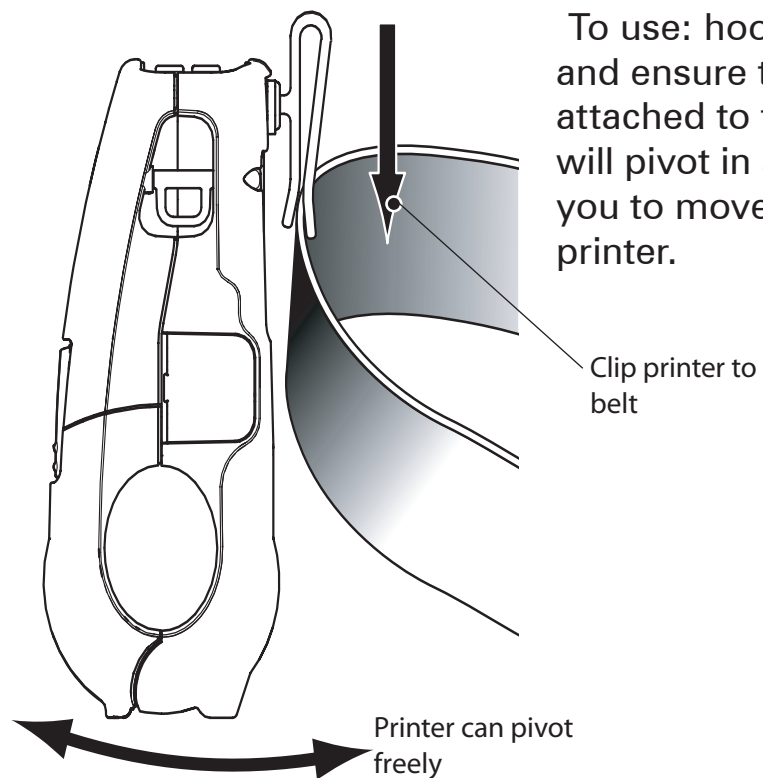

To use: hook the clip over your belt, and ensure that the clip is securely attached to the belt. The belt clip will pivot in all directions to allow you to move freely while wearing the printer.

Adjustable Shoulder Strap

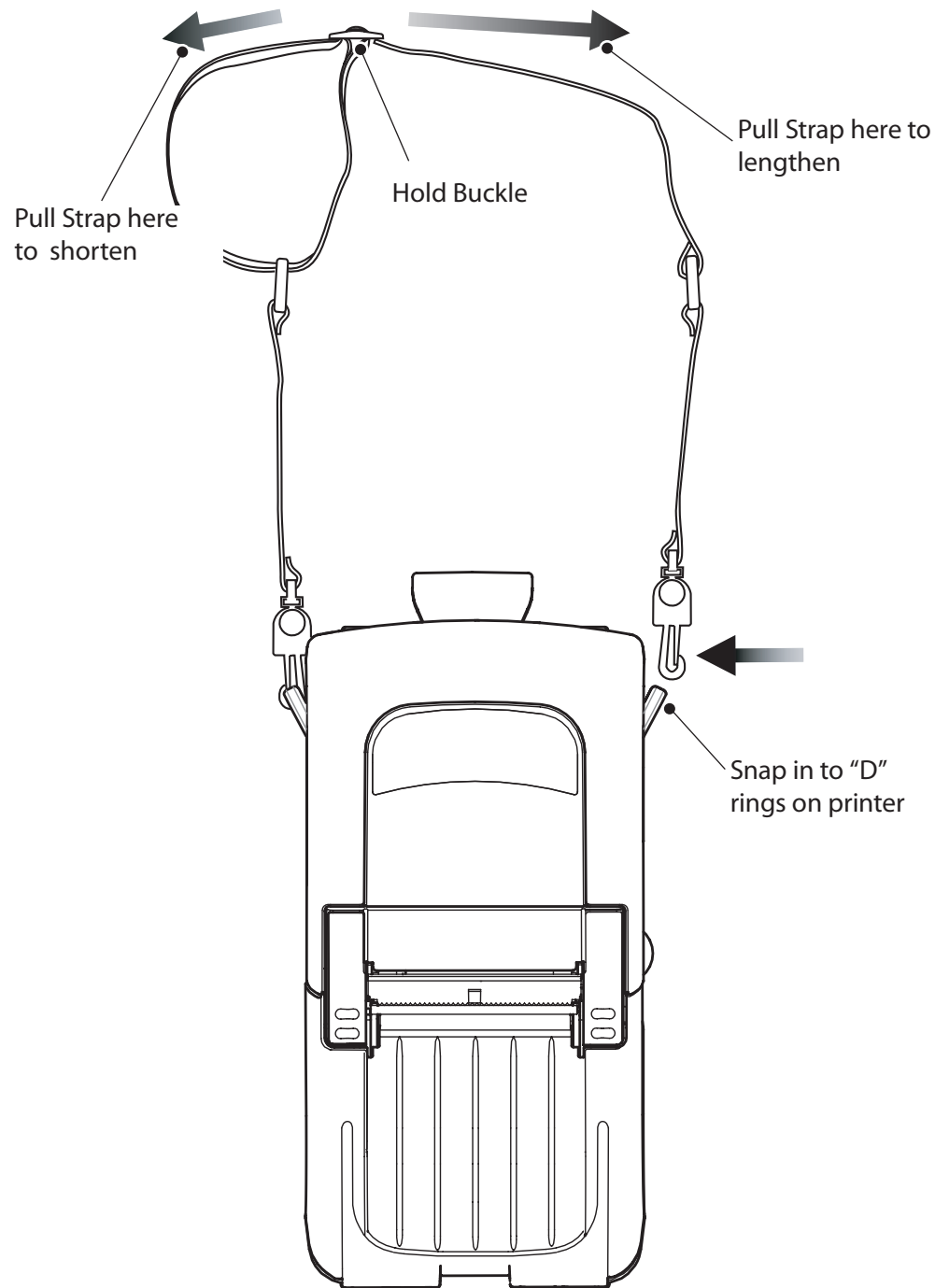

Refer to figure above. Snap each end of the shoulder strap into the "D" rings in the top of the printer. Hold the buckle and adjust the strap as shown until you achieve the desired length.

Kick Stand

Refer to the figure below. The Kickstand option allows users to use the printer on a desktop. To use the optional Kickstand: Flip the Kickstand on the back of the printer open until it locks in place. The printer will now sit at an angle on a desktop.

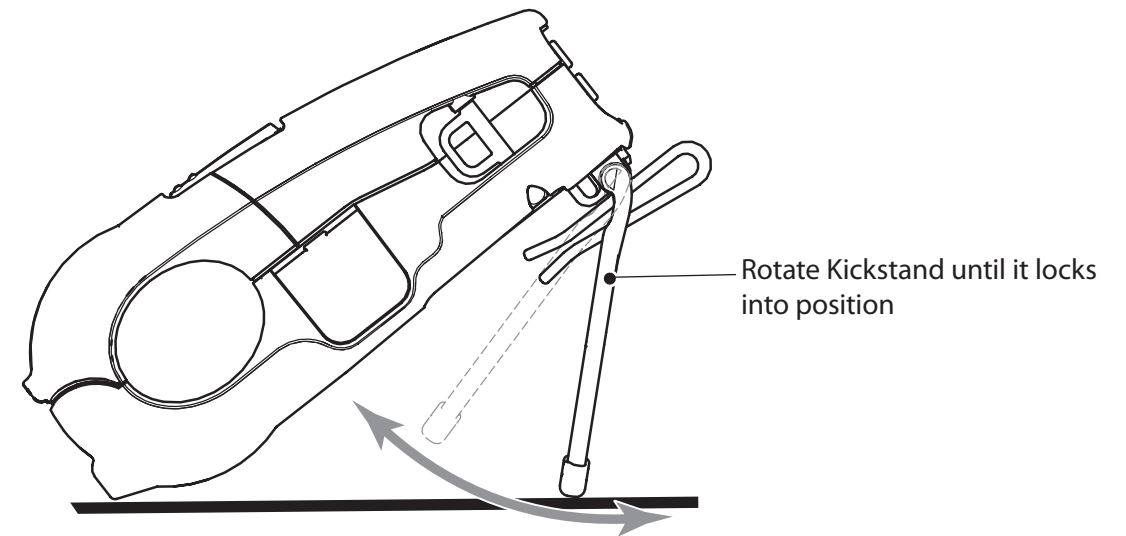

Desk Stand

Refer to the figure opposite. To use the Desk Stand: Slide the printer onto the Desk Stand shown. The printer's belt clip will hook onto Desk Stand and retain it in place. Ensure the clip is securely attached to the Stand and the media compartment of the printer is seated securely in the stand.

Holes are provided to secure the Desk Stand to the work surface. The charger and data I/O cables may be plugged into the printer in the usual manner.

 Do not charge the battery while printing.

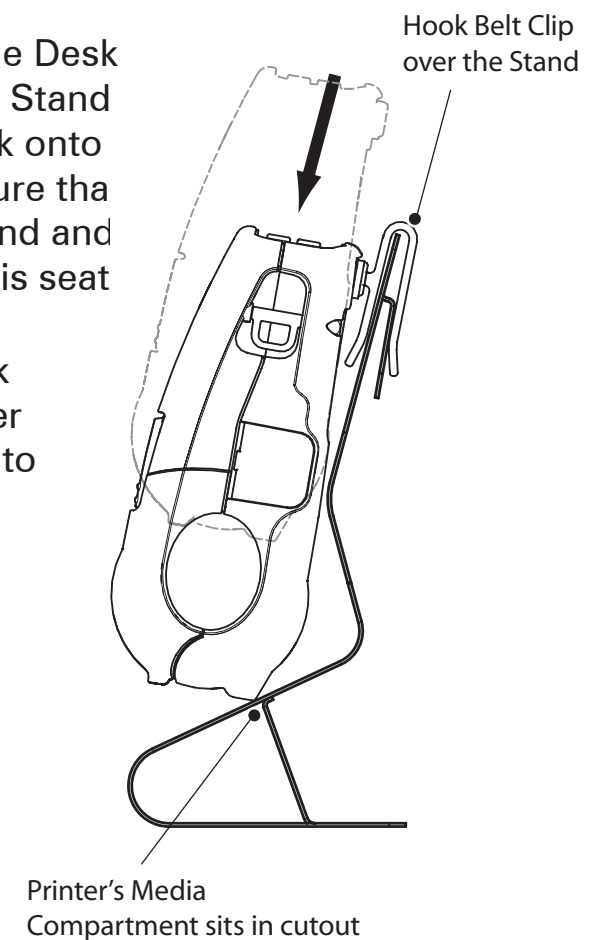

Product Support

For product support, and the latest versions of all customer documentation, contact Zebra Technologies at:
www.zebra.com

Refer to Appendix D in the QL Plus Series User Guide for more detailed contact information

IN THE AMERICAS CONTACT:

Zebra Technologies Corporation

475 Half Day Road, Suite 500
Lincolnshire, Illinois 60069 USA
Phone: +1.847.634.6700 or +1.800.423.0422
Fax: +1.847.913.8766

IN EUROPE, AFRICA, THE MIDDLE EAST, AND INDIA CONTACT:

Zebra Technologies Europe Limited

Dukes Meadow
Millboard Road
Bourne End
Buckinghamshire SL8 5XF, UK
T: +44 (0)1628 556000
F: +44 (0)1628 556001

IN THE ASIA PACIFIC REGION CONTACT:

Zebra Technologies Asia Pacific, LLC

71 Robinson Road #05-02/03
Singapore 068895
T: +65-6858 0722
F: +65-6885 0838



Zebra Technologies Corporation

475 Half Day Road, Suite 500
Lincolnshire, IL 60069 USA

T: +1 847.634.6700 or +1 800.423.0442