



Zebra® QLn-EC/QLn-EC4
Ethernet Cradle for QLn Series Printers

User Guide



P1041085-001 Rev. E
March, 2012

Contents

Product Improvements	3
FCC Compliance Statement for QLn-EC	3
FCC Compliance Statement for QLn-EC4	3
CE Compliance Statement for QLn-EC4	3
Canadian Compliance Statement	4
Agency Approvals and Regulatory Information for QLn-EC4	4
Agency Approvals and Regulatory Information for QLn-EC	4
Liability Disclaimer	5
No Liability for Consequential Damage	5
Copyrights	5
Document Conventions	6
Installation Safety	7
Indicator and Parts Descriptions	8
QLn-EC	8
Descriptions	8
Indicators and Parts Description cont.	9
QLn-EC4	9
Descriptions	9
Introduction	10
QLn-EC	10
QLn-EC4	10
Required for Installation	10
Packaging Contents	11
QLn-EC	11
QLn-EC4	11
Installation	11
Tasks for Installation	11
QLn-EC Installation	12
QLn-EC4 Installation	12
Cradle Preparation	13
Using the Printer on the Cradle	14
Printer Preparation	14
Printer Installation	15
Printer Removal	15
Printer Access	15
Cradle Indicators	16
Appendix A: Technical Specifications	17
A1: QLn-EC	17
A2: QLn-EC4	17
Technical Support	18
U.S. Only	18
All Others	18

Proprietary Statements

This manual contains proprietary information of Zebra Technologies Corporation. It is intended solely for the information and use of parties operating and maintaining the equipment described herein. Such proprietary information may not be used, reproduced, or disclosed to any other parties for any other purpose without the expressed written permission of Zebra Technologies Corporation.

Product Improvements

Since continuous product improvement is a policy of Zebra Technologies Corporation, all specifications and signs are subject to change without notice.

FCC Compliance Statement for QLn-EC

Class B digital device. Tested to comply with FCC standards for home or office use.

WARNING: Exposure to Radio Frequency radiation with certain versions of the printer used with this product. To conform to FCC RF exposure requirements this device shall be used in accordance with the operating conditions and instructions listed in the printer's User Guide. There are several radio options available with the printer used in conjunction with this product. Additional regulatory information is contained in the printer's Users Guide in sections devoted to each radio option.

Changes or modifications to this unit not expressly approved by Zebra Technologies Corporation could void the user's authority to operate this equipment.

FCC Compliance Statement for QLn-EC4

This equipment has been tested and found to comply with the limits for a Class A digital device, pursuant to Part 15 of the FCC Rules. These limits are designed to provide reasonable protection against harmful interference when the equipment is operated in a commercial environment. This equipment generates, uses, and can radiate radio frequency energy and, if not installed and used in accordance with the instruction manual, may cause harmful interference to radio communications. Operation of this equipment in a residential area is likely to cause harmful interference in which case the user will be required to correct the interference at his own expense.

WARNING: Exposure to Radio Frequency radiation with certain versions of the printer used with this product. To conform to FCC RF exposure requirements this device shall be used in accordance with the operating conditions and instructions listed in the printer's User Guide. There are several radio options available with the printer used in conjunction with this product. Additional regulatory information is contained in the printer's Users Guide in sections devoted to each radio option.

Changes or modifications to this unit not expressly approved by Zebra Technologies Corporation could void the user's authority to operate this equipment.

CE Compliance Statement for QLn-EC4

WARNING

This is a Class A product. In a domestic environment this product may cause radio interference, in which case the user may be required to take adequate measures.

Canadian Compliance Statement

This Class A digital apparatus complies with Canadian ICES-003.

Cet appareil numérique de la classe A est conforme à la norme NMB-003 du Canada.

"IC:" before the equipment certification number signifies that the Industry Canada technical specifications were met. It does not guarantee that the certified product will operate to the user's satisfaction.

Agency Approvals and Regulatory Information for QLn-EC4

- FCC part 15 Class A
- Canadian STD ICES-003 Class A
- EN55022 Class A European Electromagnetic Radiation Standard
- EN55024 European Immunity Standard
- EN60950 Safety Standard
- NOM (Mexico)
- C-Tick (Australia)
- VCCI (Japan)
- PCT (Russia)
- SABS (South Africa)
- BSMI (Taiwan)
- SII (Israel)
- KC (Korea)
- Ukrsepro (Ukraine)
- CE (EU/EFTA)

Agency Approvals and Regulatory Information for QLn-EC

- FCC part 15 Class B
- Canadian STD ICES-003 Class B
- EN55022 Class B European Electromagnetic Radiation Standard
- EN55024 European Immunity Standard
- EN60950 Safety Standard
- NOM (Mexico)
- C-Tick (Australia)
- VCCI (Japan)
- PCT (Russia)
- SABS (South Africa)
- BSMI (Taiwan)
- SII (Israel)
- KC (Korea)
- Ukrsepro (Ukraine)
- CE (EU/EFTA)

Liability Disclaimer

In as much as every effort has been made to supply accurate information in this manual, Zebra Technologies Corporation is not liable for any erroneous information or omissions. Zebra Technologies Corporation reserves the right to correct any such errors and disclaims liability resulting therefrom.

No Liability for Consequential Damage

In no event shall Zebra Technologies Corporation or anyone else involved in the creation, production, or delivery of the accompanying product (including hardware and software) be liable for any damages whatsoever (including, without limitation, damages for loss of business profits, business interruption, loss of business information, or other pecuniary loss) arising out of the use of or the results of use of or inability to use such product, even if Zebra Technologies Corporation has been advised of the possibility of such damages. Because some states do not allow the exclusion of liability for consequential or incidental damages, the above limitation may not apply to you.

Copyrights

The copyrights in this manual and the label print engine described therein are owned by Zebra Technologies Corporation. Unauthorized reproduction of this manual or the software in the label print engine may result in imprisonment of up to one year and fines of up to \$10,000 (17 U.S.C.506). Copyright violators may be subject to civil liability.

ZebraLink and all product names and numbers are trademarks, and Zebra, the Zebra logo, ZPL, ZPL II, Element Energy Equalizer Circuit, and E3 Circuit are registered trademarks of ZIH Corp. All rights reserved worldwide.

CG Triumvirate is a trademark of AGFA Monotype Corporation. All rights reserved worldwide. CG Triumviratetm font © AGFA Monotype Corporation. Intellifont® portion © AGFA Monotype Corporation. All rights reserved worldwide. UFST is a registered trademark of AGFA Monotype Corporation. All rights reserved worldwide.

All other brand names, product names, or trademarks belong to their respective holders.

©2012 ZIH Corp

Document Conventions

The following conventions are used throughout this document to convey certain information:



Caution • Warns you of the potential for electrostatic discharge.



Caution • Warns you of a potential electric shock situation.



Warning • Indicates an imminently hazardous situation which, if not avoided, will result in death or serious injury. Before you work on any equipment, be aware of the hazards involved with the electrical circuitry and be familiar with standard practices for preventing accidents.



Caution • Warns you of a situation where excessive heat could cause a burn



Caution • Advises you that failure to take or avoid a specific action could result in physical harm to you.



Caution • Advises you that failure to take or avoid a specific action could result in physical harm to the hardware.



Important • Advises you of information that is essential to complete a task.



Note • Indicates neutral or positive information that emphasizes or supplements important points of the main text.

Installation Safety



Caution • Only trained and qualified personnel should be allowed to install, replace, or service this equipment.



Warning • It is very important to ensure that the correct power adaptor is connected to the cradle.



Note • Zebra Technologies Corporation is not liable for personal injury or damage to any equipment caused by the improper installation of this equipment to any power source.



Caution • This equipment should be installed in accordance with this installation guide and under the supervision of properly trained and qualified personnel.



Caution • Do not place coins, keys, paper clips, or other objects on the cradle or the 16-pin connectors.



Caution • Use only the approved power supply for the QLn-EC and QLn-EC4. Use of an alternative power supply will void the product warranty and may cause product damage.

Indicator and Parts Descriptions

QLn-EC

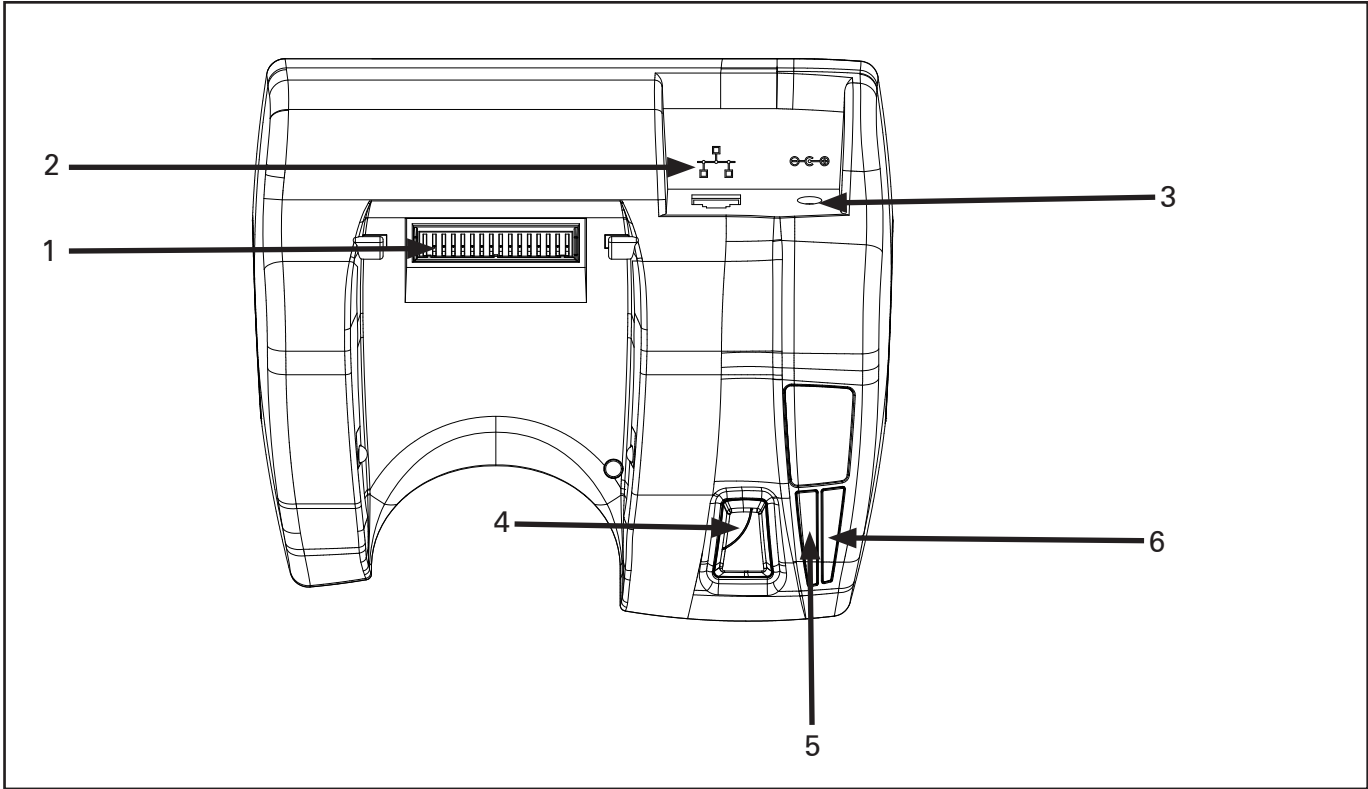

Figure 1: QLnEC

Descriptions

1. 16-pin docking port connector
2. Ethernet RJ-45 jack
3. DC power input jack
4. Eject printer button
5. Ethernet link indicator
6. Power indicator

Indicators and Parts Description cont.

QLn-EC4

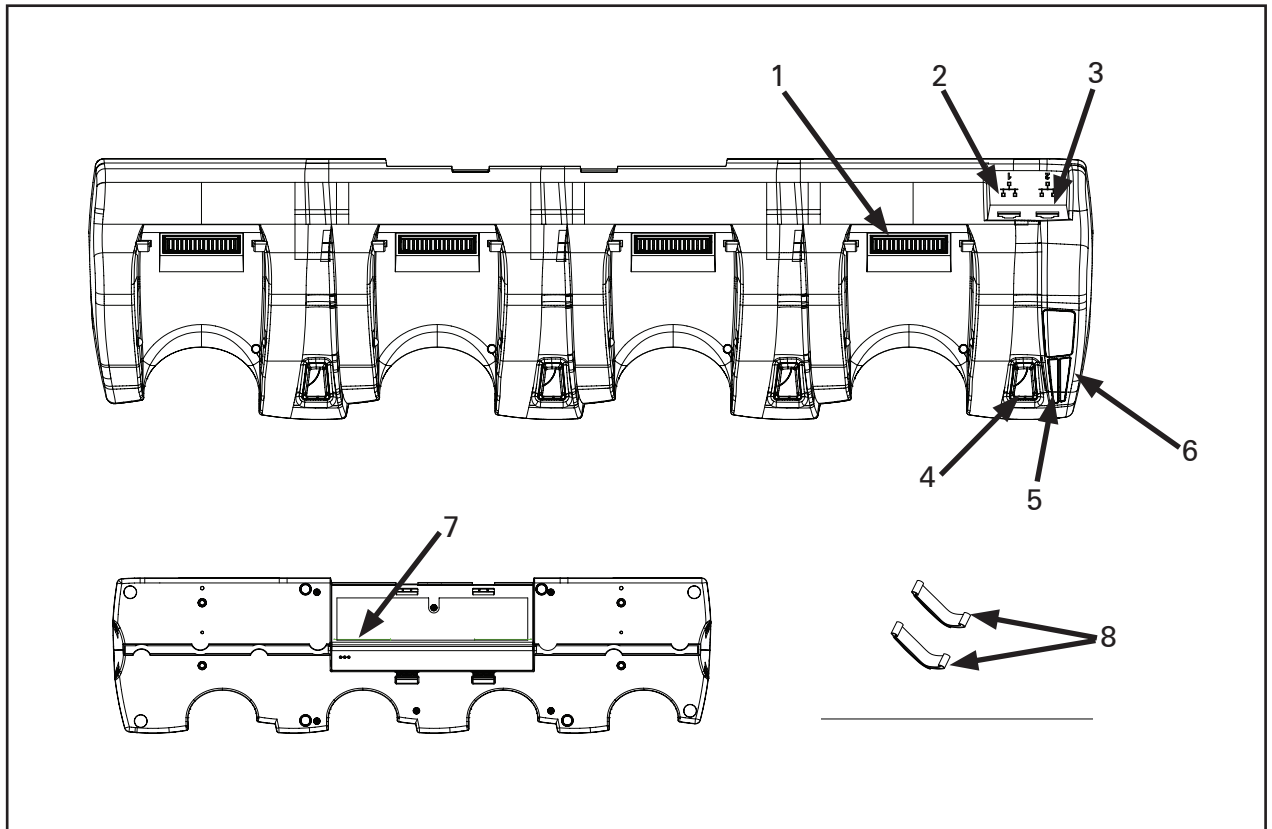

Figure 2: QLnEC4

Descriptions

1. 16-pin docking connector
2. Ethernet jack
3. Ethernet jack 2 (used to daisy chain other Ethernet cradles)
4. Eject printer button
5. Ethernet link indicator
6. Power indicator
7. DC power jack
8. Velcro belt (used to fasten the power adapter)

Introduction

QLn-EC

The QLn-EC Cradle allows the QLn family of printers to connect to an Ethernet Network. The cradle also provides battery charging power while still maintaining all of the printer's functionality.

The cradle has two input connections:

- A DC supply input that connects to the supplied AC power adapter.
- An RJ-45 connector for connection to the Ethernet Network.

QLn-EC4

The QLn-EC4 Quad Cradle allows the QLn family of printers to connect to an Ethernet Network. It allows a maximum of four (4) QLn-EC4 Quad cradles to be daisy chained together. The cradle also provides battery charging power while still maintaining all of the printer's functionality.

The cradle has two (2) inputs and one output connections:

- A DC supply input that connects to the supplied AC power adaptor.
- An RJ-45 connector for connection, Ethernet Jack 1 to the Ethernet Network.
- An RJ-45 connector, Ethernet Jack 2 for daisy chaining connections to other QLn-EC4 Quad cradles.

The following instructions detail the installation and use of the cradle. Following these instructions closely will ensure safe, reliable performance of the printer when docked on the cradle.

The printer runs off its own battery, which is monitored and charged by circuitry within the printer.

The user should always refer to the QLn Series Users Guide for complete information on using the printer.

Required for Installation

If you need to attach the cradle (either QLn-EC or QLn-EC4) on the desktop, the below tools and parts are necessary

- An electrical drill, 1/4"(6 mm) drill bit
- Common hand tools.
- #10-32 bolts with self-locking (ESN) nuts



Note • Use of appropriate hardware to secure the cradle to the desktop or wall is the responsibility of the installer.

A wall mount kit is available for the QLn-EC4 cradle (p/n P1031365-050).

Packaging Contents

QLn-EC

- The QLn-EC Cradle
- Documentation CD (containing User Guide)
- AC Power Adapter
- Region-specific power cord

QLn-EC4

- The QLn-EC4 Cradle
- Documentation CD (containing User Guide)
- AC Power Adapter
- Region-specific power cord
- Velcro belt

Installation

The QLn-EC allows you to dock a QLn printer (4 printers for QLn-EC4). The installation of the cradle includes an AC power adapter, which provides power to run the printers and charge their batteries. An Ethernet cable (supplied by the user) is required to connect the cradle to the Ethernet Network. The cradle supports either 10mbps or 100mbps networks.

The Cradle is secured with #10-32 mounting hardware 2 place for QLn-EC, 4 places for QLn-EC4 on the desktop, if desired.



Note • Hardware used to secure the cradle on the desktop is not supplied in the installation kit.

Tasks for Installation

QLn-EC:

- Mechanically prepare and install the EC Cradle.
- Connect the power adapter to the cradle.
- Connect the Ethernet cable to the cradle and the Ethernet Network.

QLn-EC4

- Mechanically prepare and install the EC Quad Cradle.
- Fix the power adaptor underneath of the cradle.
- Connect the power adaptor to the cradle.



Note • It is important to leave a free zone around the printer to allow the loading of paper.

QLn-EC Installation

The QLn-EC is intended to rest on a flat surface such as a table or shelf. It may be attached using the mounting holes shown in the diagram below.

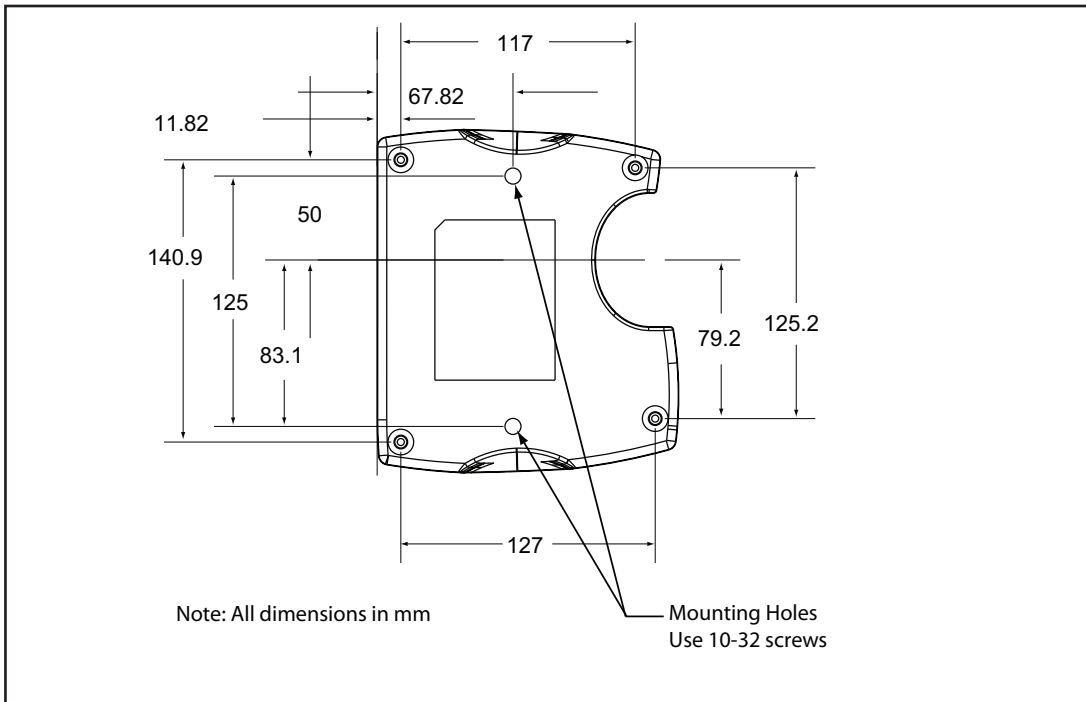

QLn-EC4 Installation

The QLn-EC4 is intended to rest on a flat surface such as a table or shelf. It may be attached using the mounting holes shown in the first diagram below. It may also be wall mounted using the optional "L" brackets illustrated below.

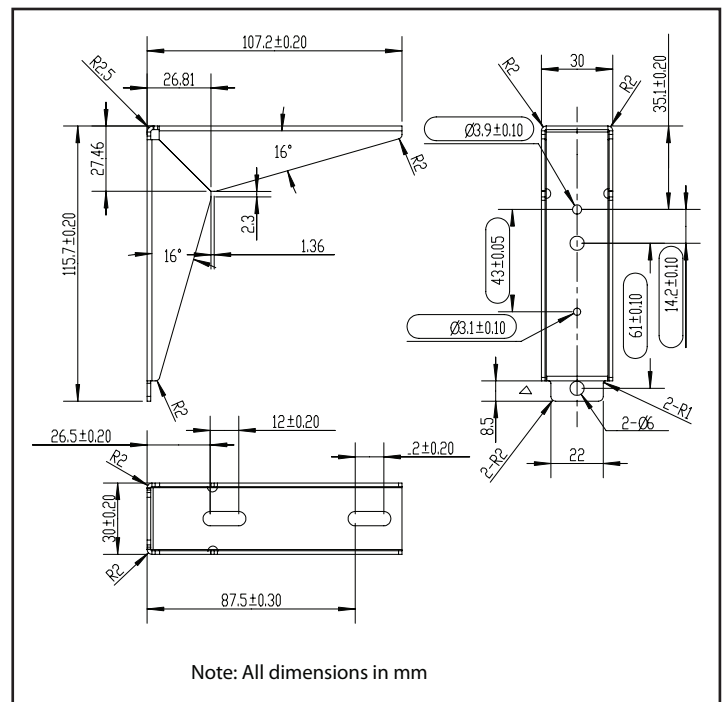
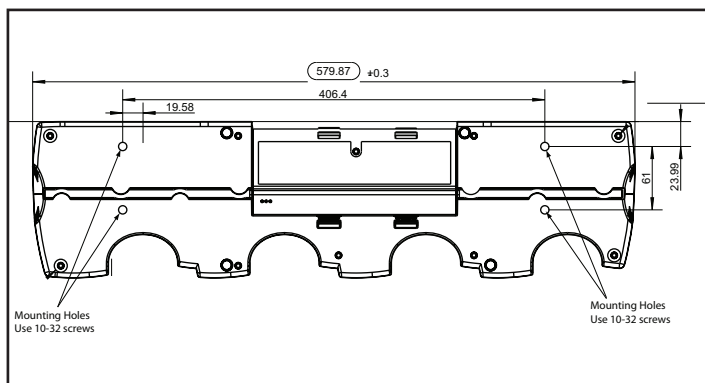

Cradle Preparation

Plan your installation with the above considerations in mind. Locate the printers and cradle so that the operator can easily load printing media and operate the printer's controls.

QLn-EC

1. Select a location with flat surface with a free zone around the printer to allow for the loading of media.
2. Plug the power adapter into the rear of the cradle (Figure 1 #3).
3. Plug the Ethernet cable into the rear of the cradle (Figure 1 #2).
4. Make sure that the AC power adapter cable routing does not invite damage to the cable. To avoid unintentional contact between the wire and any sharp edges, provide the cable with proper bushings and clamping where it passes through openings.

QLn-EC4

1. Select a location with flat surface with a free zone around the printer to allow loading of media.
2. Plug the power adaptor into the DC jack at the bottom of the cradle (Figure 2 #7).
3. Fix the AC power adaptor underneath the cradle by fastens with supplied Velcro belts shown below.

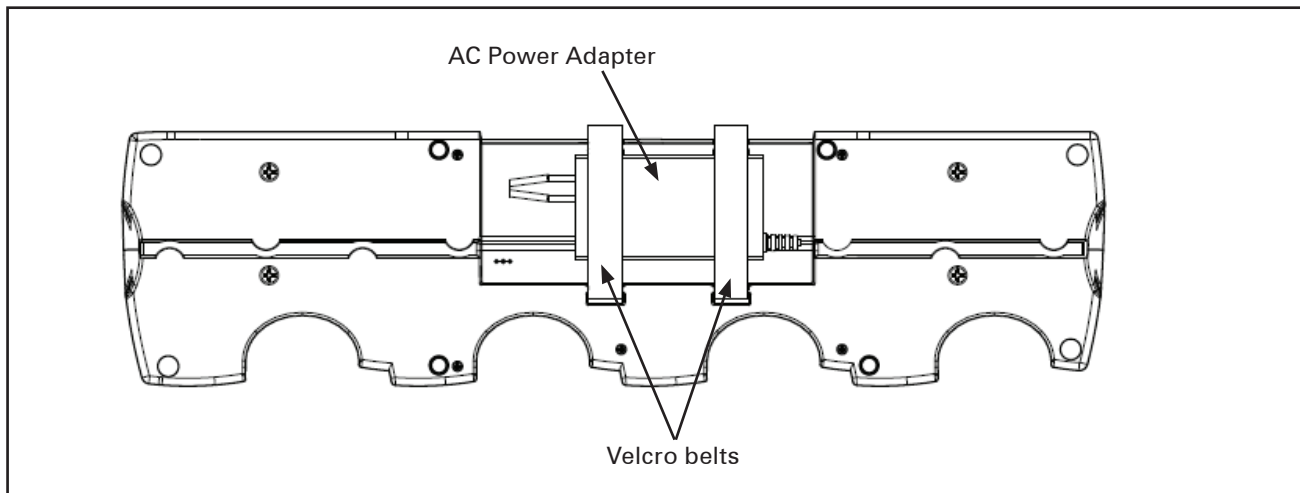

4. Plug the Ethernet cable into the Ethernet Jack 1 (Figure 2 #2) at the rear of the cradle. Make sure that the AC power adapter cable routing does not invite damage to the cable. To avoid unintentional contact between the wire and any sharp edges, provide the cable with proper bushings and clamping where it passes through openings.
5. Connect up to four (4) cradles in series by using the connection at Ethernet Jack 2 (Figure 2 #3).

Using the Printer on the Cradle



Note • Each QLn-EC4 cradle requires an AC power adapter for proper operation even under daisy chain connections.



Note • To ensure proper operation, a maximum of four (4) cradles (with up to 16 printers) can be daisy chained together.

Printer Preparation

Prepare the printer for docking onto the cradle by doing the following:



It is strongly recommended as a safety precaution that the adjustable shoulder strap or hand strap be removed prior to docking the printer. This precaution will ensure the strap will not interfere with proper operation.

- Always install the battery prior to placing the printer in the cradle.
- Remove the black sticker on the bottom of the printer that covers the docking contacts. The sticker is labeled “Docking Cradle Access” and is illustrated below.



- If necessary, clean any residue from the docking contacts using the cleaning pen that comes with the printer, or a cotton swab with 70% Isopropyl alcohol.
- All QLn series printers will charge when docked on the cradle. For Ethernet connectivity, make sure the Ethernet option is installed in the printer. See the QLn Series User Guide for instructions.

Printer Installation

The QLn printer can now be placed on the Ethernet Cradle.

- Place the bottom of the printer over the two guide slot over the 16 pin connector.
- Slide the printer onto the cradle gently and press firmly until it latches in place.
- Verify the charge LED indicator on the front of the printer and power indicator LED (Figures 1 & 2 #6) on the cradle's panel are lit.
- If not already on, the printer will automatically turn on when docked in the cradle. Print a configuration label to verify that the printer is functioning properly. Refer to the QLn User's Guide for instructions on printing a configuration label.

Printer Removal

Remove the printer from the Ethernet Cradle by doing the following:

- Press the Eject button (Figures 1 & 2 #4) on the cradle and pivot the printer out of the Cradle.
- The printer can also be removed without using the Eject button simply by rocking it backwards.

Printer Access

- The media compartment and operator controls can be reached while the printer is placed on the cradle.
- If you need to take out the printer, follow the removal procedure detailed above in the Printer Installation and Removal section.
- If using a printer that has a Bluetooth radio, that radio may be used while the printer is docked.
- The serial and USB ports on the printer can be used while the printer is docked.
- The DC input barrel jack connection on the printer can NOT be used while the printer is in the cradle.
- If using a printer with an 802.11 wireless LAN radio, the printer will automatically turn off that radio and connect to the Ethernet port when docked, and will automatically revert to 802.11 when undocked. It is possible to force the 802.11 radio to remain active when the printer is docked, if for example, the cradle is only being used as a charging station. Contact Technical Support for assistance with this change in behavior.

Cradle Indicators

The cradle has two (2) LED indicators on the panel. The power LED (#6 in Figures 1 & 2) is green when power is supplied to the cradle.

Charging status will be displayed on the charge LED on the front of the printer.

A fault condition could be caused by the battery's internal temperature exceeding its specified limits (too hot or too cold) or could be caused by an internal short in the battery. Allow the battery to return to specified charging temperature range and try to recharge.

If the fault condition persists, discontinue use of the battery.

Note • If the charge LED on the Printer is not illuminated, the printer is not seated properly in the cradle. Eject and re-dock the printer and observe if the charging LED is illuminated.

A second green LED represents the Ethernet link status indicator (#5 in Figures 1 & 2). It will blink to indicate the data communication between the printer and the network.

Appendix A: Technical Specifications

A1: QLn-EC

Physical

- Height: 2.4 in (60 mm)
- Length: 5.5 in (140 mm)
- Width: 6.4 in (162 mm)
- Weight (cradle only): 0.65 lbs (0.3 kg)
- Weight (cradle, AC adapter, line cord): 1.35 lbs (0.61 kg)

Environmental

- Operating Temp: 32°F (0°C) to 104°F (40°C)
- Storage Temp: -13°F (-25°C) to 158°F (65°C)
- Humidity: 10% to 90% non-condensing
- Drop: 5 ft (1.5M) to concrete (without printer)
- Vibration: Per Mil-Std-810

AC Adapter:

- AC Input: 100 – 240 VAC, 50 – 60 Hz, 0.8A
- DC Output: 12VDC, 2.08A
- 2011 Energy Star Compliant

Ethernet:

- 10/100 base-T
- Auto-sensing

A2: QLn-EC4

Physical

- Height: 2.4 in (60 mm)
- Length: 5.9 in (151 mm)
- Width: 22.8 in (580 mm)
- Weight (cradle only): 2.4 lbs (1.1 kg)
- Weight (cradle, AC adapter, line cord): 3.2 lbs (1.4 kg)

Environmental

- Operating Temp: 32°F (0°C) to 104°F (40°C)
- Storage Temp: -13°F (-25°C) to 158°F (65°C)
- Humidity: 10% to 90% non-condensing
- Drop: 5 ft (1.5M) to concrete (without printers)
- Vibration: Per Mil-Std-810

AC Adapter:

- AC Input: 100 – 240 VAC, 50 – 60 Hz, 1.5A
- DC Output: 12VDC, 4.16A
- 2011 Energy Star Compliant

Ethernet:

- 10/100 base-T
- Auto-sensing

Technical Support

U.S. Only

Zebra maintains a help line for questions involving installation and use of the EC Quad Cradle. Please have as much information as possible regarding your particular application ready when you call to enable the technical support personnel to help you. The number in the U.S. is (800)-423-0442 and is open Monday through Friday from 8:00 am to 4:30 P.M. E.S.T.

All Others

For technical support, please contact your local Zebra sales representative listed below:

Zebra Technologies Europe Limited
Dukes Meadow
Millboard Road
Bourne End
Buckinghamshire SL8 5XF, UK
T: +44 (0)1628 556000
F: +44 (0)1628 556001

Zebra Technologies Asia Pacific, LLC
120 Robinson Road
#06-01 Parakou Building
Singapore 068913
T: +65 6858 0722
F: +65 6885 0838

Zebra Technologies
Latin America Sales Office
9800 NW 41 Street
Suite 220
Doral, Florida 33178 USA
T: +1.305.558.8470
F: +1.305.558.8485



Zebra Technologies Corporation
475 Half Day Road, Suite 500
Lincolnshire, IL 60069 USA
T: +1 847.634.6700 or +1 800.423.0442