

PS30

Personal Shopper



ZEBRA

Product Reference Guide

2024/11/11

ZEBRA and the stylized Zebra head are trademarks of Zebra Technologies Corporation, registered in many jurisdictions worldwide. All other trademarks are the property of their respective owners. ©2024 Zebra Technologies Corporation and/or its affiliates. All rights reserved.

Information in this document is subject to change without notice. The software described in this document is furnished under a license agreement or nondisclosure agreement. The software may be used or copied only in accordance with the terms of those agreements.

For further information regarding legal and proprietary statements, please go to:

SOFTWARE: zebra.com/informationpolicy.

COPYRIGHTS: zebra.com/copyright.

PATENTS: ip.zebra.com.

WARRANTY: zebra.com/warranty.

END USER LICENSE AGREEMENT: zebra.com/eula.

Terms of Use

Proprietary Statement

This manual contains proprietary information of Zebra Technologies Corporation and its subsidiaries ("Zebra Technologies"). It is intended solely for the information and use of parties operating and maintaining the equipment described herein. Such proprietary information may not be used, reproduced, or disclosed to any other parties for any other purpose without the express, written permission of Zebra Technologies.

Product Improvements

Continuous improvement of products is a policy of Zebra Technologies. All specifications and designs are subject to change without notice.

Liability Disclaimer

Zebra Technologies takes steps to ensure that its published Engineering specifications and manuals are correct; however, errors do occur. Zebra Technologies reserves the right to correct any such errors and disclaims liability resulting therefrom.

Limitation of Liability

In no event shall Zebra Technologies or anyone else involved in the creation, production, or delivery of the accompanying product (including hardware and software) be liable for any damages whatsoever (including, without limitation, consequential damages including loss of business profits, business interruption, or loss of business information) arising out of the use of, the results of use of, or inability to use such product, even if Zebra Technologies has been advised of the possibility of such damages. Some jurisdictions do not allow the exclusion or limitation of incidental or consequential damages, so the above limitation or exclusion may not apply to you.

Contents

| | |
|-------------------------------------|-----------|
| About This Guide..... | 10 |
| Configurations..... | 10 |
| Notational Conventions..... | 10 |
| Icon Conventions..... | 11 |
| Service Information..... | 11 |
| Determining Software Versions..... | 11 |
| Determining the Serial Number..... | 12 |
| | |
| Getting Started..... | 13 |
| Unpacking the Device..... | 13 |
| Device Features..... | 14 |
| Setting Up the Device..... | 16 |
| Installing the Battery..... | 17 |
| Replacing the Battery..... | 19 |
| Charging the Device..... | 23 |
| Installing an EAS Tag..... | 28 |
| Zebra Visibility Services..... | 32 |
| | |
| Using the Device..... | 33 |
| Home Screen..... | 33 |
| Status Bar..... | 34 |
| Managing Notifications..... | 37 |
| Opening the Quick Access Panel..... | 38 |
| Setting Home Screen Rotation..... | 40 |
| Battery Management..... | 40 |

| | |
|---|-----------|
| Checking Battery Status..... | 40 |
| Monitoring Battery Usage..... | 40 |
| Low Battery Notification..... | 41 |
| Interactive Sensor Technology..... | 41 |
| Waking the Device..... | 41 |
| USB Communication..... | 42 |
| Transferring Files..... | 42 |
| Disconnecting from the Host Computer..... | 42 |
| Settings..... | 43 |
| Accessing Settings..... | 43 |
| Display Settings..... | 43 |
| Setting the Screen Brightness Manually..... | 43 |
| Setting Night Light..... | 43 |
| Setting Screen Rotation..... | 44 |
| Setting Screen Timeout..... | 44 |
| Setting Ambient Display..... | 44 |
| Setting Font Size..... | 45 |
| Setting Touch Panel Mode..... | 45 |
| Setting the Date and Time..... | 45 |
| General Sound Settings..... | 45 |
| Sound Options..... | 46 |
| Keyboards..... | 46 |
| Keyboard Configuration..... | 46 |
| Using the Android and Gboard Keyboards..... | 47 |
| Enterprise Keyboard..... | 48 |
| Language Usage..... | 48 |
| Notifications..... | 49 |
| Setting App Notifications..... | 49 |
| Viewing Notifications..... | 49 |
| Controlling Lock Screen Notifications..... | 50 |
| Applications..... | 51 |

| | |
|---|-----------|
| Installed Applications..... | 51 |
| Accessing Apps..... | 52 |
| Switching Between Recently Used Apps..... | 52 |
| Battery Manager..... | 53 |
| Battery Manager Information..... | 53 |
| Updating Cradle Firmware..... | 55 |
| Sending the File Using the Recovery Method..... | 57 |
| Cradle Utility..... | 57 |
| Controlling the Cradle..... | 57 |
| Setting the Cradle..... | 58 |
| Performing Cradle Diagnostics..... | 59 |
| Viewing Cradle Information..... | 60 |
| DataWedge Demonstration..... | 61 |
| DataWedge Demonstration Icons..... | 61 |
| Selecting a Scanner..... | 61 |
| RxLogger..... | 62 |
| RxLogger Configuration..... | 62 |
| Configuration File..... | 62 |
| Enabling Logging..... | 62 |
| Disabling Logging..... | 62 |
| Extracting Log Files..... | 62 |
| Backing Up Data..... | 63 |
| RxLogger Utility..... | 63 |
| Data Capture..... | 65 |
| Scanning Considerations..... | 65 |
| Scanning Barcodes..... | 66 |
| Decode Screen Notification..... | 66 |
| Hands-Free Scanning..... | 67 |
| Scanning Mode..... | 68 |
| Proximity Range..... | 69 |
| DataWedge..... | 69 |
| Enabling DataWedge..... | 70 |
| Disabling DataWedge..... | 70 |

| | |
|--|-----------|
| Supported Decoders..... | 70 |
| SE4710 Internal Imager Supported Decoders..... | 70 |
| Wireless..... | 72 |
| Wireless Local Area Networks..... | 72 |
| Connecting to a Wi-Fi Network..... | 73 |
| Removing a Wi-Fi Network..... | 73 |
| WLAN Configuration..... | 74 |
| Configuring a Secure Wi-Fi Network..... | 74 |
| Manually Adding a Wi-Fi Network..... | 75 |
| Configuring for a Proxy Server..... | 76 |
| Configuring the Device to Use a Static IP Address..... | 77 |
| Wi-Fi Preferences..... | 77 |
| Additional Wi-Fi Settings..... | 78 |
| Wi-Fi Direct..... | 78 |
| Bluetooth..... | 79 |
| Adaptive Frequency Hopping..... | 79 |
| Security..... | 79 |
| Bluetooth Profiles..... | 80 |
| Bluetooth Power States..... | 80 |
| Bluetooth Radio Power..... | 81 |
| Discovering Bluetooth Device(s)..... | 81 |
| Changing the Bluetooth Name..... | 81 |
| Connecting to a Bluetooth Device..... | 82 |
| Selecting Profiles on the Bluetooth Device..... | 82 |
| Unpairing a Bluetooth Device..... | 82 |
| Cast..... | 82 |
| Near Field Communication..... | 82 |
| Reading NFC Cards..... | 83 |
| Enterprise NFC Settings..... | 83 |
| Accessories..... | 85 |
| Device Accessories..... | 85 |

| | |
|---|------------|
| Accessories for Charging..... | 88 |
| 1-Slot Cradle..... | 89 |
| 3-Slot Cradle..... | 99 |
| Releasing the Device from Locking Charging Cradles..... | 113 |
| Software Release Using the Menu..... | 113 |
| Software Release Using the Cradle Utility..... | 113 |
| Manual Release Using a Release Key..... | 113 |
| USB Programming Cable..... | 115 |
| Installing the USB Programming Cable..... | 115 |
| Connecting the Device to the Host Computer..... | 116 |
| Removing the USB Programming Cable..... | 117 |
| Soft Holster..... | 118 |
| Using the Belt Clip..... | 119 |
| Using the Shoulder Strap..... | 121 |
| Application Deployment..... | 124 |
| Security..... | 124 |
| Secure Certificates..... | 124 |
| Installing a Secure Certificate..... | 124 |
| Configuring Credential Storage Settings..... | 125 |
| Android Development Tools..... | 125 |
| Android Development Workstation..... | 125 |
| Enabling Developer Options..... | 125 |
| EMDK for Android..... | 126 |
| StageNow for Android..... | 126 |
| GMS Restricted..... | 126 |
| ADB USB Setup..... | 126 |
| Enabling USB Debugging..... | 127 |
| Application Installation Methods..... | 127 |
| Installing Applications Using the USB Connection..... | 128 |
| Installing Applications Using the Android Debug Bridge..... | 128 |
| Uninstalling an Application..... | 129 |
| Android System Update..... | 129 |
| Performing a System Update Using ADB..... | 129 |

| | |
|--|------------|
| Entering into Recovery Mode..... | 130 |
| Verifying System Update Installation..... | 130 |
| Android Enterprise Reset..... | 130 |
| Performing an Enterprise Reset From Device Settings..... | 131 |
| Performing an Enterprise Reset Using ADB..... | 131 |
| Android Factory Reset..... | 132 |
| Performing a Factory Reset Using ADB..... | 132 |
| Android Storage..... | 133 |
| Random Access Memory..... | 133 |
| Internal Storage..... | 134 |
| Enterprise Folder..... | 134 |
| Managing Apps..... | 134 |
| Managing Downloads..... | 135 |
| Maintenance and Troubleshooting..... | 136 |
| Maintaining the Device and Accessories..... | 136 |
| Battery Safety Guidelines..... | 136 |
| Cleaning Instructions..... | 137 |
| Approved Cleanser Active Ingredients..... | 137 |
| Harmful Ingredients..... | 138 |
| Device Cleaning Instructions..... | 138 |
| Special Cleaning Notes..... | 138 |
| Cleaning Materials Required..... | 138 |
| Cleaning Frequency..... | 139 |
| Cleaning the Device..... | 139 |
| Cleaning Battery Connectors..... | 139 |
| Cleaning Cradle Connectors..... | 139 |
| Troubleshooting..... | 140 |
| Resetting the Device..... | 140 |
| Entering into Recovery Mode..... | 141 |
| Troubleshooting the Device..... | 142 |
| Cradle Troubleshooting..... | 143 |

Specifications..... 144

- Data Capture Supported Symbologies..... 144
- Interface Connector Pin-Outs.....144
- Accessory Specifications.....145
 - 1-Slot Cradle Technical Specifications..... 145
 - 3-Slot Cradle Technical Specifications..... 145
- Cable Specifications..... 146
 - Power Supply Cable, Y-type Specifications..... 146
 - Cradle Interconnection Cable Specifications.....146

About This Guide

This guide provides information about setting up and using the PS30 personal shopper. Some screens shown in this guide may differ from the images shown on the device.

This guide includes Android operating system (OS) 13 and above.

Configurations

PS30 used in this document refers to all configurations except where noted.

Table 1 Configurations

| Configuration | Radios | Display | Memory | Data Capture Options | Operating System |
|---|--|--------------------|--------------------------|----------------------|-------------------------------|
| PS30 Base | WLAN: 802.11a/b/g/n/ac/d/h/i/ax WPAN: Bluetooth V5.3 | WVGA 4.7 in. color | 6 GB RAM/ 64 GB Flash | SE4710 + Digimarc | Google™ Mobile Services (GMS) |
| PS30 Plus (includes Sensors and NFC ^a) | WLAN: 802.11a/b/g/n/ac/d/h/i/ax WPAN: Bluetooth V5.3 | WVGA 4.7 in. color | 6 GB RAM/ 64 GB Flash | SE4710 + Digimarc | Google™ Mobile Services (GMS) |

^a ISO 14443 Type A and B; Mifare, FeliCa and ISO 15693 cards; Card Emulation via Host; Contactless payment support, Google Smart Tap ready, CPoC Compliant

Notational Conventions

The following notational conventions make the content of this document easy to navigate.

- **Bold** text is used to highlight the following:
 - Dialog box, window, and screen names
 - Dropdown list and list box names
 - Checkbox and radio button names
 - Icons on a screen
 - Key names on a keypad
 - Button names on a screen

- Bullets (•) indicate:
 - Action items
 - List of alternatives
 - Lists of required steps that are not necessarily sequential.
- Sequential lists (for example, those that describe step-by-step procedures) appear as numbered lists.

Icon Conventions

The documentation set is designed to give the reader more visual clues. The following visual indicators are used throughout the documentation set.



NOTE: The text here indicates information that is supplemental for the user to know and that is not required to complete a task.



IMPORTANT: The text here indicates information that is important for the user to know.



CAUTION: If the precaution is not heeded, the user could receive a minor or moderate injury.



WARNING: If danger is not avoided, the user CAN be seriously injured or killed.



DANGER: If danger is not avoided, the user WILL be seriously injured or killed.

Service Information

If you have a problem with your equipment, contact Zebra Global Customer Support for your region. Contact information is available at: zebra.com/support.

When contacting support, please have the following information available:

- Serial number of the unit
- Model number or product name
- Software type and version number

Zebra responds to calls by email, telephone, or fax within the time limits set forth in support agreements.

If your problem cannot be solved by Zebra Customer Support, you may need to return your equipment for servicing and will be given specific directions. Zebra is not responsible for any damages incurred during shipment if the approved shipping container is not used. Shipping the units improperly can possibly void the warranty.

If you purchased your Zebra business product from a Zebra business partner, contact that business partner for support.

Determining Software Versions

Before contacting Customer Support, determine the current software version on your device.

1. Swipe down from the Status bar with two fingers to open the Quick Access panel, and then touch .

2. Touch **About phone**.
3. Scroll to view the following information:
 - Model
 - Android version
 - Build number

Determining the Serial Number

Before contacting Customer Support, determine the serial number of your device.

1. Swipe down from the Status bar with two fingers to open the Quick Access panel, and then touch .
2. Touch **About phone**.
3. Touch **Model**.
4. Touch **Serial number**.

Getting Started

This section provides information to get the device up and running for the first time.

Unpacking the Device

Unpacking the PS30 personal shopper from the box.

1. Carefully remove all protective material from the device and save the shipping container for later storage and shipping.
2. Verify the following items are in the box:
 - PS30 personal shopper
 - Lithium-ion battery
 - Regulatory guide
3. Inspect the equipment. If anything is missing or damaged, contact the Global Customer Support Center immediately.
4. Before using the device for the first time, remove the protective shipping film that covers the display.

Device Features

This section lists the features of the PS30 personal shopper.

Figure 1 Front View

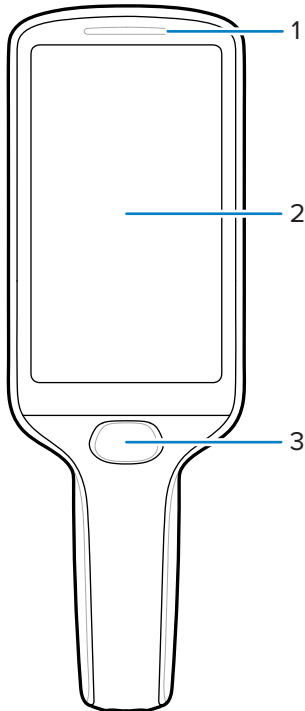

Table 2 Device Front View

| Number | Item | Description |
|--------|--------------|--|
| 1 | LED status | Indicates the battery charge state while charging or the scan/decode status. <ul style="list-style-type: none"> • Red: Barcode scan in progress. (Scan key is pressed with Decoding LED Notification enabled*.) • Single Green Blink: Successful decode. |
| 2 | Touch screen | Displays all information needed to operate the device. |
| 3 | Scan key | This key functions in the following ways: <ul style="list-style-type: none"> • Turns on the device when pressed and held for 3 seconds. • Operates the imager when a scanning application is active. • Functions as a Select/Enter key. |

* To enable Decoding LED Notification, do the following:

1. Swipe up from the bottom of the screen, and open the DWDemo app.

2. Touch the three dots on the lower-right corner, and then touch **Settings**.
3. Touch **Configure scanner settings > Scan params**.
4. Touch the checkbox to enable **Decoding LED Notification**.

Figure 2 Side and Rear View

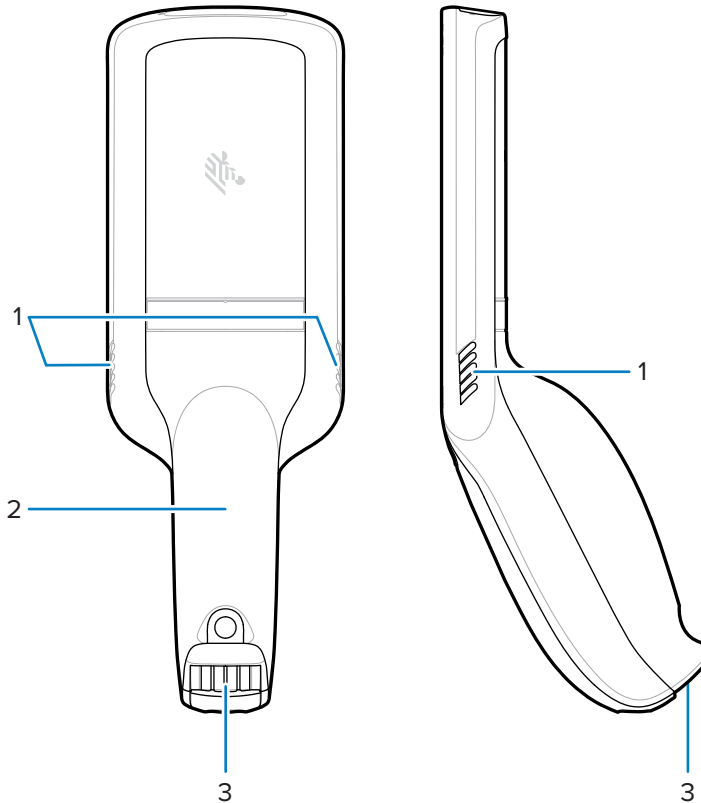
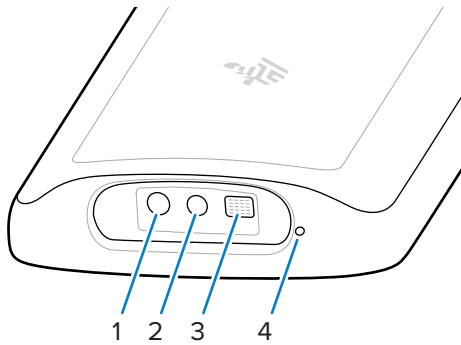

Table 3 Device Rear and Side View

| Number | Item | Description |
|--------|----------------------------|--|
| 1 | Speakers | Provides audio output for video, music, and notifications. |
| 2 | Battery cover | Encloses the battery and attaches to the device's handle. |
| 3 | Power/Cradle I/O Connector | Provides charging via cradle and cradle communication to lock/unlock the cradle slots. Use to perform a hard reset with the terminal reboot tool. For more information, see Interface Connector Pin-Outs . |

Figure 3 Front View Showing Scan Exit Window**Table 4** Device Front View

| Number | Item | Description |
|--------|---------------|--|
| 1 | Red dot aimer | Provides a background aiming pattern, which allows positioning of the barcode within the imager's field of view. |
| 2 | Imager | Scans and reads barcodes. |
| 3 | Illuminator | Provides increased visibility in bright lighting conditions. |
| 4 | Microphone | Use for audio input and SmartLens locationing. Allows shoppers to speak to a store associate or to a virtual assistant via speech-to-text. |

Setting Up the Device

To start using the device for the first time, you must set it up.

1. Charge the device to at least 30% capacity.
2. Power on the device.

When the device is shipped from the factory, it is placed into Ship Mode, where the device enters its lowest possible power state. The device can exit Ship Mode by docking it in a powered cradle. Fully charging the battery pack to 100% is recommended immediately after exiting Ship Mode to calibrate the state of charge.

Installing the Battery

Follow these instructions to install the battery into the PS30 personal shopper.

1. Using a Phillips (PH00) screwdriver, loosen the captive screw that secures the battery cover.

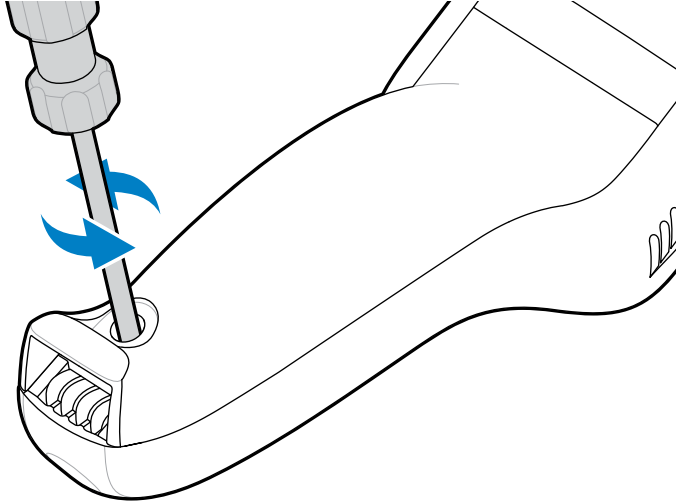

2. Rotate the battery cover up, and remove it from the handle.

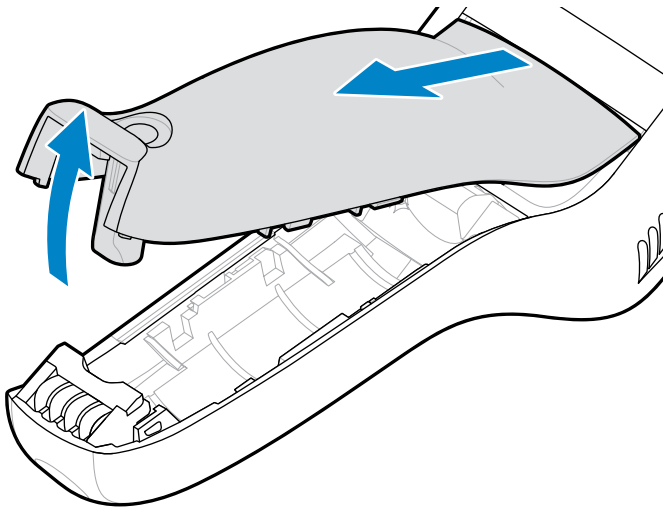

3. With the plastic tab facing the device's handle, press the battery's cable connector into the power connector. The connector is designed to fit only one way.

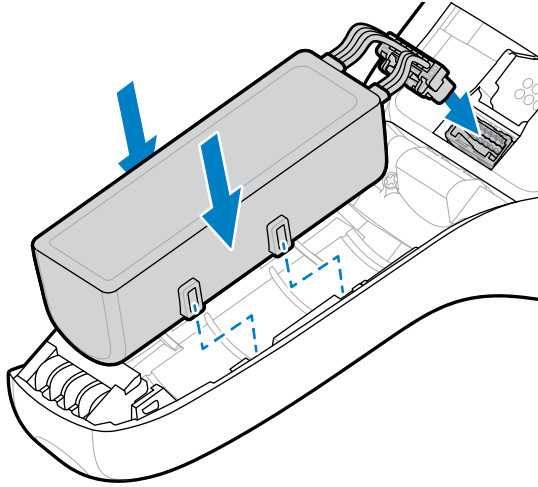

4. Position the battery inside the battery compartment.
5. Insert the tabs on the battery cover into the handle, and then push the bottom of the battery cover down.

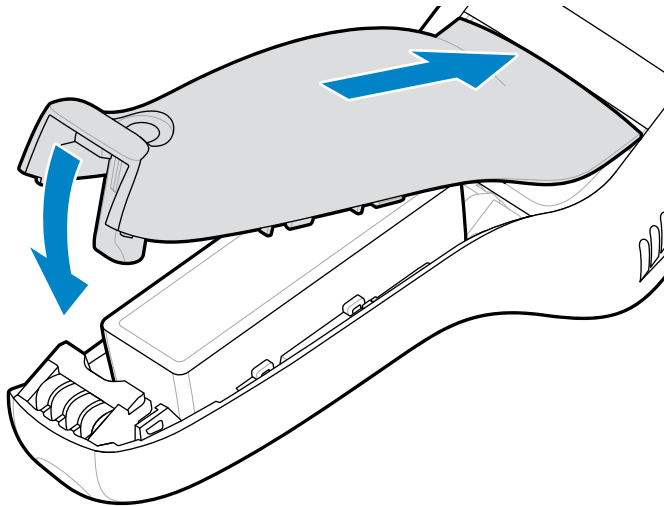

- Using a Phillips (PH00) screwdriver, tighten the screw that secures the battery cover to the device.

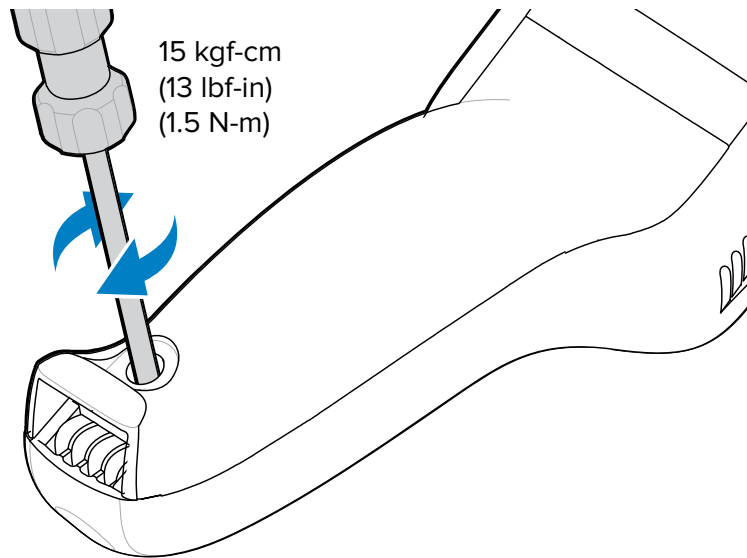

- Press and hold the Scan key to power on the device.

Replacing the Battery

Follow these instructions to replace the battery in the PS30 personal shopper.



IMPORTANT: To ensure that all data is written to the file system, power down the device before you remove the battery.

- Touch and hold the scan key to wake the device.
- Touch and hold .
- Touch **Power off**.
- Using a Phillips (PH00) screwdriver, loosen the captive screw that secures the battery cover.

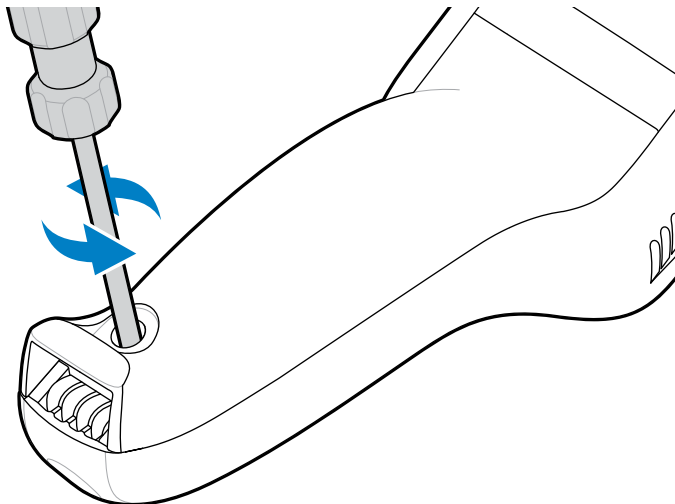

5. Rotate the battery cover up, and remove it from the handle.

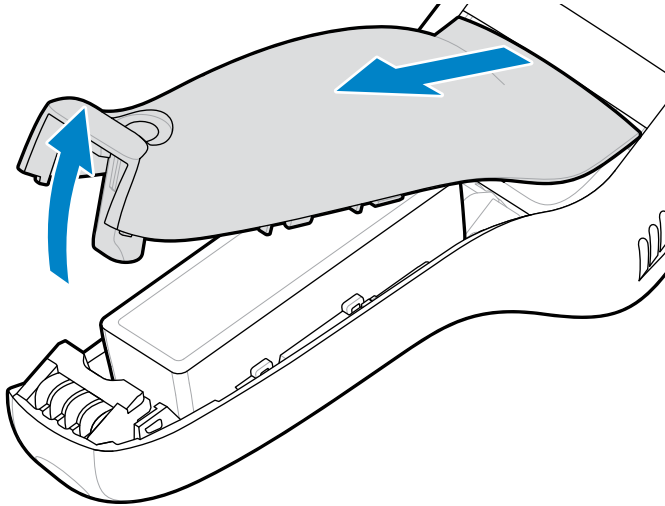

6. Lift the battery to access the plastic tab on the battery cable connector, and then pinch the tab to release the connector.

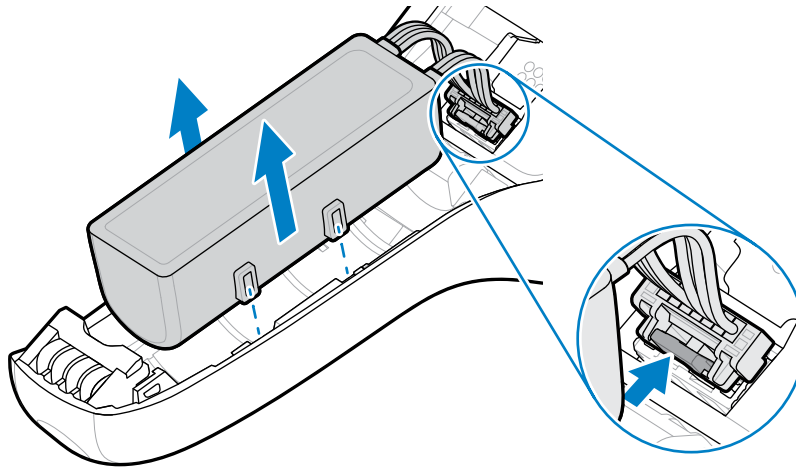

7. Remove the battery from the battery compartment.

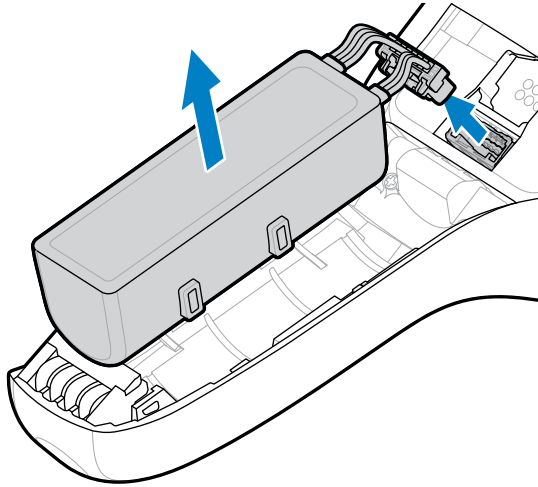

8. With the plastic tab facing the device's handle, press the new battery's cable connector into the power connector. The connector is designed to fit only one way.

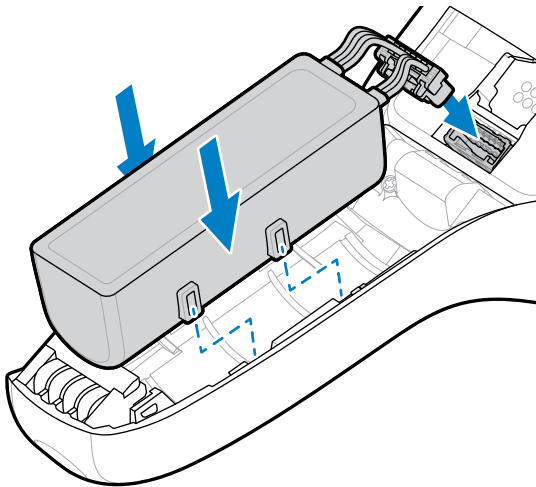

9. Position the battery inside the battery compartment.

10. Insert the tabs on the battery cover into the handle, and then push the bottom of the battery cover down.

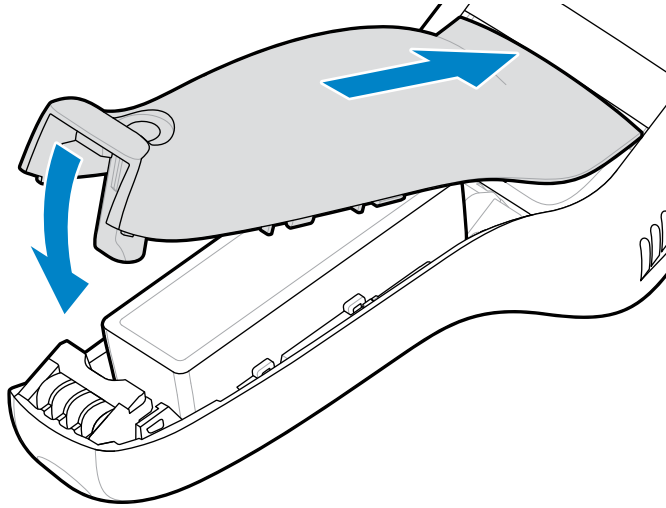

11. Using a Phillips (PH00) screwdriver, tighten the screw that secures the battery cover to the device.

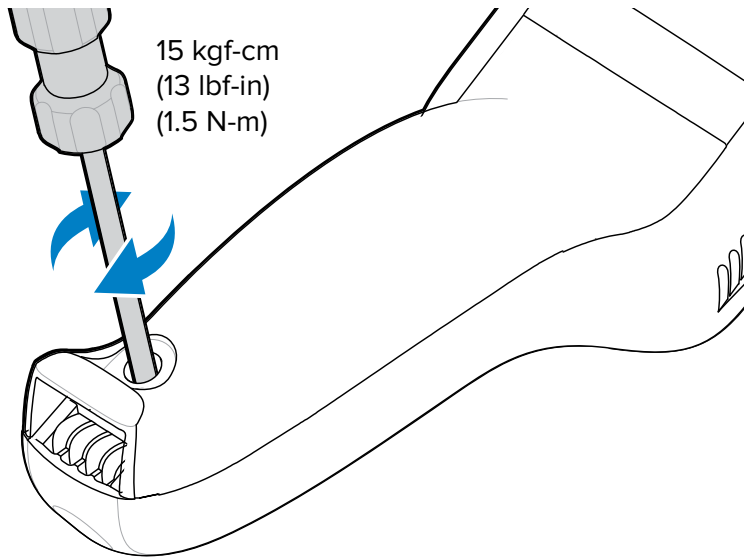

Compatibility with MC18 and PS20

The table displays the compatibility of the PS30 devices and accessories with the MC18 and PS20 devices and accessories.

Table 5 Compatibility

| | PS30 Batteries | PS20 Batteries | MC18 Batteries | MC18 Cradles |
|------|----------------|----------------|----------------|--------------|
| PS30 | Yes | No | No | Yes |
| PS20 | No | Yes | No | Yes |

Table 5 Compatibility (Continued)

| | PS30 Batteries | PS20 Batteries | MC18 Batteries | MC18 Cradles |
|------|----------------|----------------|----------------|--------------|
| MC18 | No | No | Yes | Yes |

- PS30 batteries are compatible with all PS30 devices and with MC18 1-slot and 3-slot cradles.
- PS30 batteries are not compatible with MC18 or PS20 devices.
- PS20 batteries are not compatible with MC18 or PS30 devices.
- MC18 batteries are not compatible with PS20 or PS30 devices.

Battery Comparison with MC18

The table displays a comparison of the PS20/PS30 batteries with the MC18 batteries.

Table 6 Battery Comparison

| Feature | MC18 | PS20 | PS30 |
|------------------|-------------------|-------------------|-------------------|
| Battery Type | PowerPrecision+ | PowerPrecision+ | PowerPrecision+ |
| Battery Capacity | 2,275 mAh | 3,500 mAh | 3,500 mAh |
| Charging Mode | Standard and Fast | Standard and Fast | Standard and Fast |

Charging the Device

To achieve optimal charging results, use only Zebra charging accessories and batteries. Charge batteries at room temperature with the device in sleep mode.

The device or accessory always performs battery charging in a safe and intelligent manner. The device or accessory indicates when charging is disabled due to abnormal temperatures via its LED, and a notification appears on the device display.

The battery charges from 0 to 90% depending on the following conditions, measured at room temperature:

- In normal charge mode, the charge time is less than 4 hours.
- In fast charge mode, the charge time is less than 3 hours.

| Temperature | Battery Charging Behavior |
|----------------------|--|
| 0–40°C (32 to 104°F) | Optimal charging range. |
| Above 37°C (98°F) | The device or cradle may, for small periods of time, alternately enable and disable battery charging to keep the battery at acceptable temperatures. |

1. Connect the charging accessory to the appropriate power source.

2. Insert the device into a cradle.

Figure 4 1-Slot Cradle

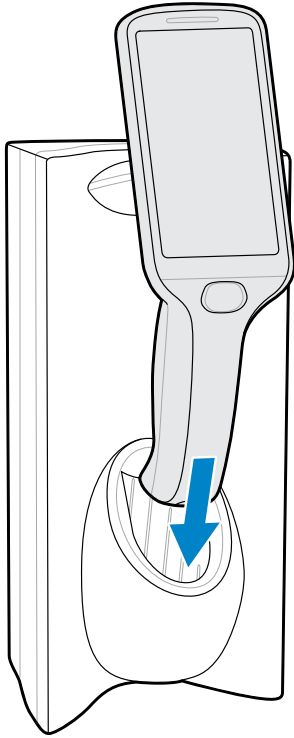
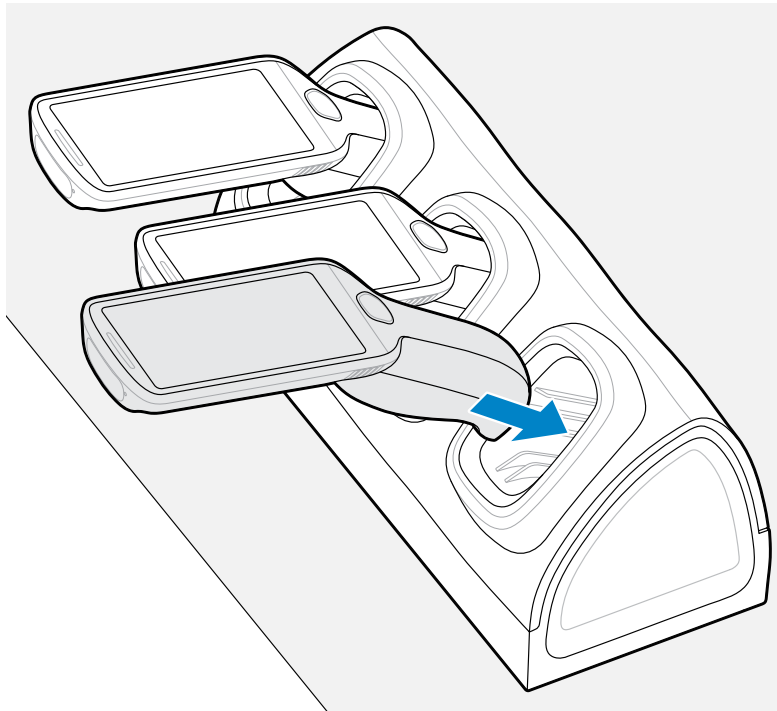

Figure 5 3-Slot Cradle, Desktop Configuration



The device turns on and begins charging, and the LED status bar blinks green.

See Also

[Accessories for Charging](#)

Imaging and Charging Indicators

The Status LED indicates imaging and charging status.

Figure 6 Status LED

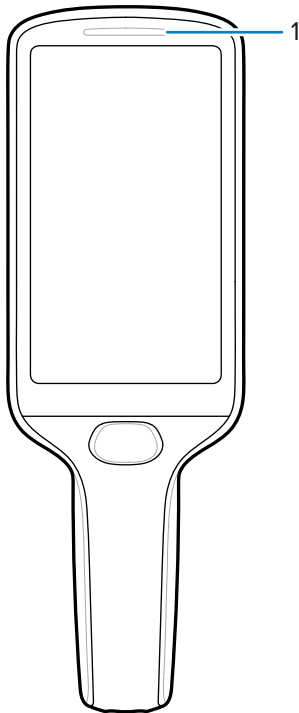

| | |
|---|-------------------------------|
| 1 | LED status/charging indicator |
|---|-------------------------------|

Table 7 Status/Charging Indicators

| Status | LED | Indications |
|----------------|--------------------|--|
| Imaging | Off | Normal operation, or the device is turned off. |
| | Red | Imaging in progress. (Scan key is pressed.) |
| | Single Green Blink | Successful decode. |

Table 7 Status/Charging Indicators (Continued)

| Status | LED | Indications |
|---|----------------|--|
| Charging (device docked in cradle) | Off (default) | One of the following: <ul style="list-style-type: none"> Power is not applied to the cradle. The device is not inserted properly. The charging LED feature is disabled. To enable it, go to Settings > Display > Charging LED |
| | Blinking Green | Charging. |
| | Solid Green | Charging is complete. |
| | Blinking Red | Charging error. For example: <ul style="list-style-type: none"> Temperature is too low or too high. Charging has gone on too long without completion (typically 8 hours). The battery is not connected properly. Go to Replacing the Battery for instructions on how to disconnect and reconnect the battery. |

Releasing the Device from Locking Charging Cradles

Use one of the following methods to release the PS30 from locking charging cradles:

- [Software Release Using the Menu](#)
- [Software Release Using the Cradle Utility](#)
- [Manual Release Using a Release Key](#)



NOTE: Devices can also be removed via any customer application that uses the EMDK personal shopper interface.

Software Release Using the Menu

The device cradles contain a locking mechanism, which locks the device inside the cradle when the device is docked. The device releases from the cradle when a software command is received from the system.

1. Touch and hold .
2. Touch **Cradle unlock**.
The cradle unlocks the device.
3. Remove the device from the cradle.

Software Release Using the Cradle Utility

The device cradles contain a locking mechanism, which locks the device inside the cradle when the device is docked. The device releases from the cradle when a software command is received from the system.

1. On the Home screen, swipe up from the bottom of the screen.

2. Touch **CradleUtility**.
3. Tap the **CRADLE UNLOCK** tab to set the cradle unlock information.
4. Touch **Unlock Cradle**.
The cradle unlocks the device.
5. Remove the device from the cradle.

Manual Release Using a Release Key

The device cradles contain a locking mechanism, which locks the device inside the cradle when the device is docked. If the device fails to unlock during normal operation, use a release key (KT-MC18-CKEY-20) to unlock the device.



CAUTION: Do not use any device to unlock the cradle other than the tools described in this section. Failure to comply could result in damage to the cradle and void the warranty.

Manual Release from the 1-Slot Cradle

1. Insert the release key (1) into the slot located on the bottom of the cradle.

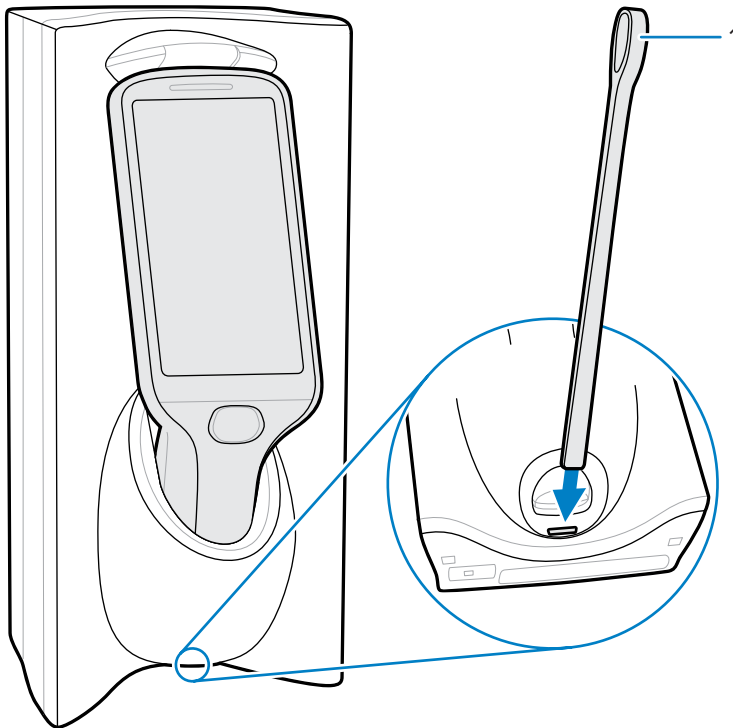

2. While pressing the release key all the way into the slot, remove the device from the cradle.

Manual Release from the 3-Slot Cradle

1. Insert the release key (1) straight into the slot in front of the device, to a point where the bend stops.

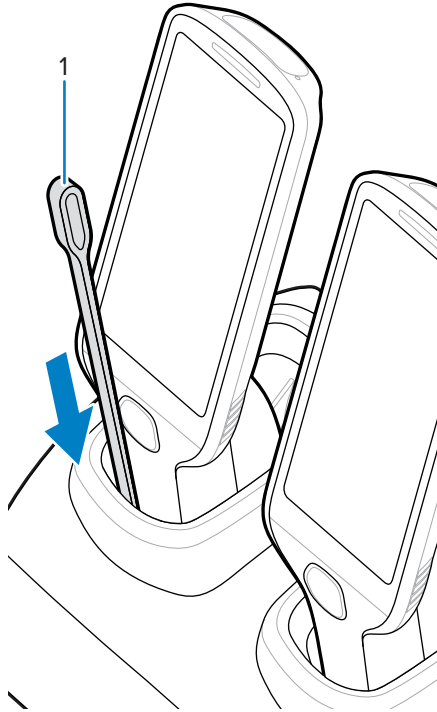

2. While holding the release key inside the slot, remove the device.

Installing an EAS Tag

An Electronic Article Surveillance (EAS) tag can be installed on the device to help prevent the device from being lost or stolen.

1. Using a Phillips (PH00) screwdriver, loosen the captive screw that secures the battery cover.

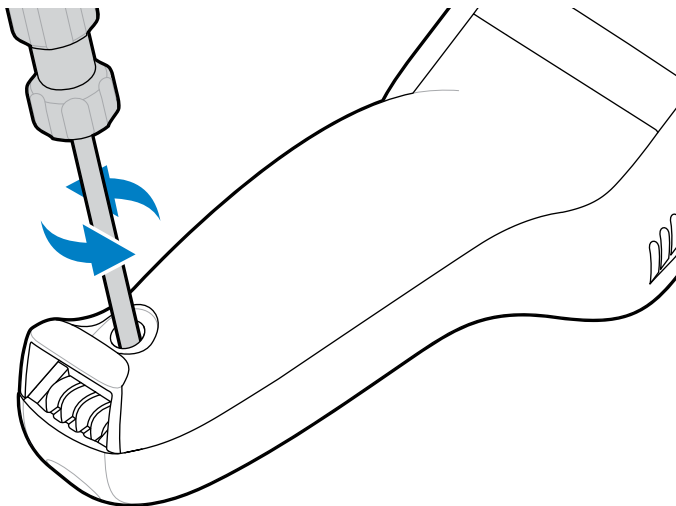

2. Rotate the battery cover up, and remove it from the handle.

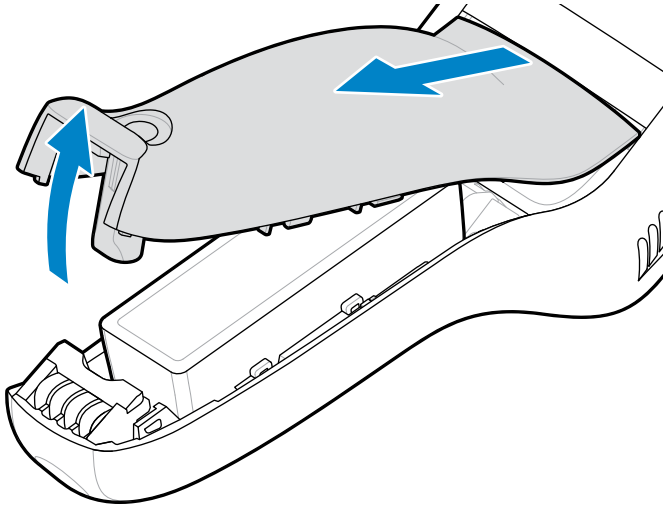

3. Insert one side of the EAS tag into the rubber boot with the orange capacitor facing up in the opening.

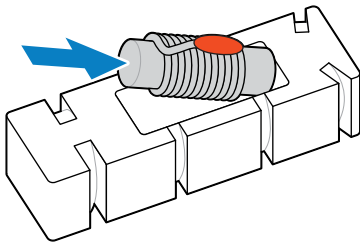

4. Press down on the other end of the tag to seat it into the rubber boot.

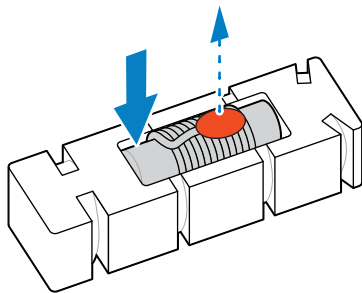

5. Install the rubber boot into the device handle in the orientation shown, with the opening and the orange capacitor facing the handle.

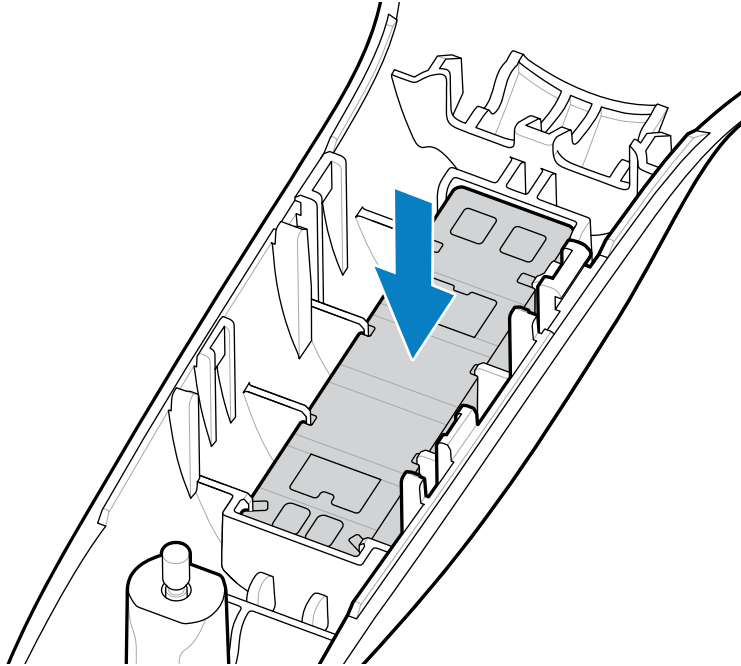

6. Insert the tabs on the battery cover into the handle, and then push the bottom of the battery cover down.

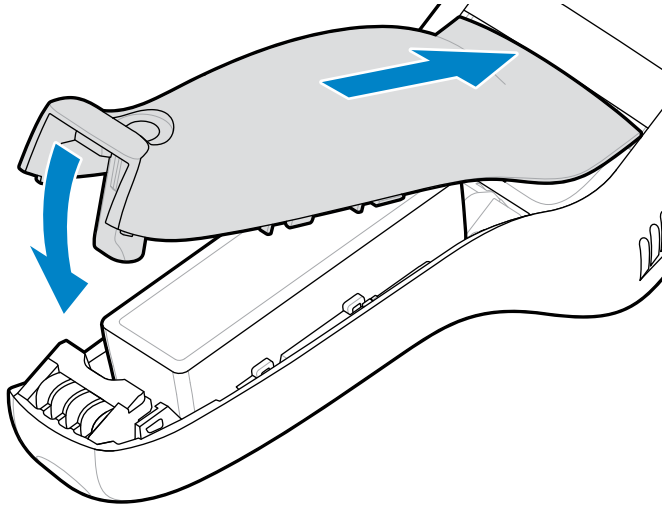

- Using a Phillips (PH00) screwdriver, tighten the screw that secures the battery cover to the device.

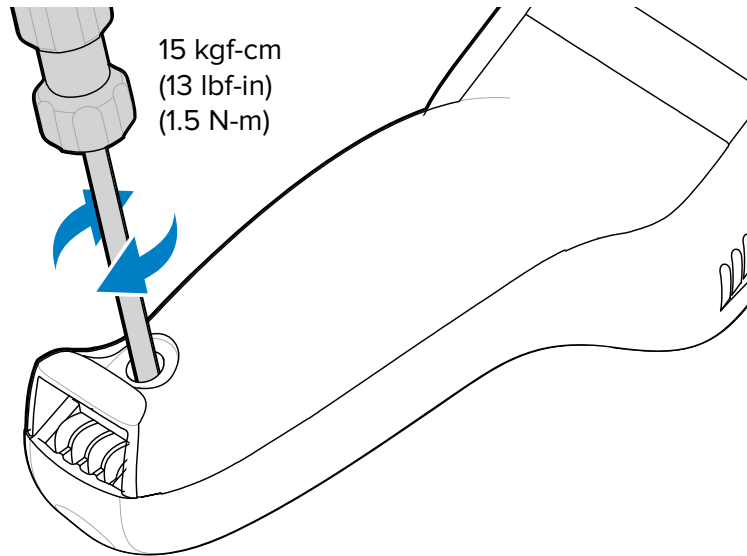

NOTE: To remove the rubber boot from the cover, use pliers to pull up on the rib in the top center of the boot.

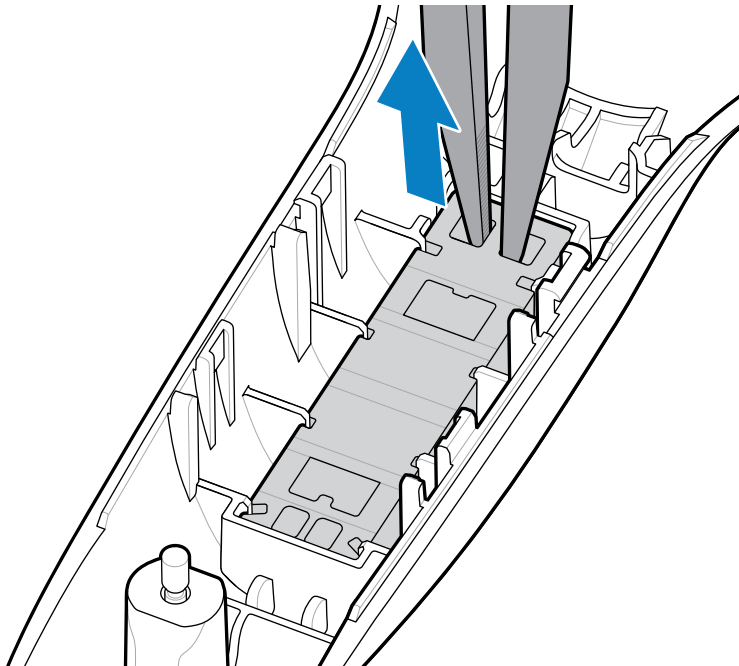

Zebra Visibility Services

The device captures and provides device analytics to a system administrator. The first time the device boots (or after a Factory reset), the **Zebra Services** agreement screen displays.

1. Leave **Device Data** enabled if you want the device to send analytics data. Zebra recommends keeping this option enabled.
2. Touch the **Device Data** switch to disable the device from sending analytics data.
3. Touch **OK** to confirm your selection.

Using the Device

This section explains how to use the device.

Home Screen

Turn on the device to display the Home screen. Depending on how your system administrator configured your device, your Home screen may appear differently than the graphics in this section.

Figure 7 Home Screen

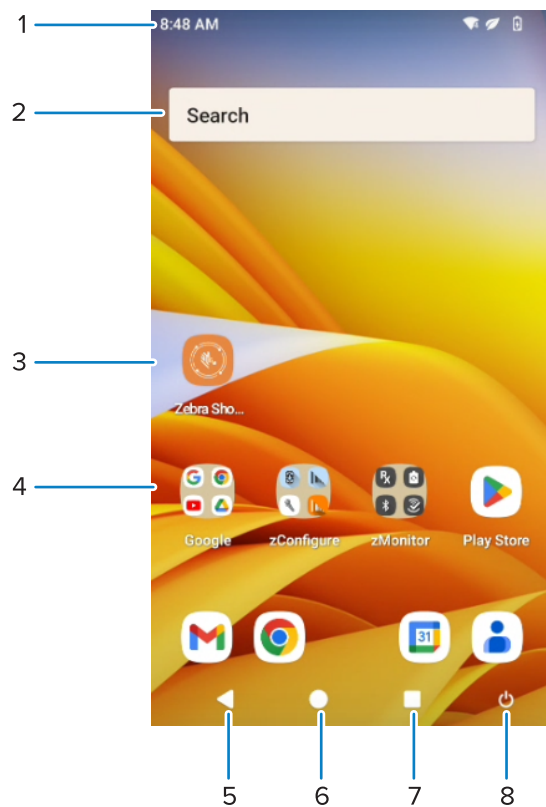

| | | |
|---|------------|---|
| 1 | Status bar | Displays the time, status icons (right side), and notification icons (left side). |
| 2 | Widgets | Launches stand-alone apps that run on the Home screen. |

| | | |
|---|----------------|--------------------------------------|
| 3 | Shortcut icons | Opens apps installed on the device. |
| 4 | Folder | Contains apps. |
| 5 | Back | Displays the previous screen. |
| 6 | Home | Displays the Home screen. |
| 7 | Recent | Displays recently used applications. |
| 8 | Power | Turns off the screen display. |

Status Bar

The Status bar displays the time, notification icons (left side), and status icons (right side).

If there are more notifications than can fit in the Status bar, a dot is displayed, indicating that more notifications exist. Swipe down from the Status bar to open the Notification panel and view all notifications and status.

Figure 8 Notifications and Status Icons



| | |
|---|--------------------|
| 1 | Notification icons |
| 2 | Status icons |









Notification Icons

Notification icons indicate app events and messages.

Table 8 Notification Icons

| Icon | Description |
|------|--|
| | The main battery is low. |
| | More notifications are available for viewing. |
| | Data is syncing. |
| | Indicates an upcoming event. AOSP devices only. |
| | Indicates an upcoming event. GMS devices only. |
| | An Open Wi-Fi network is available. The device is not connected to it. |

Table 8 Notification Icons (Continued)

| Icon | Description |
|--|--|
|  | Audio is playing. |
|  | A problem with sign-in or sync has occurred. |
|  | The device is uploading data. |
|  | Animated: the device is downloading data. Static: the download is complete. |
|  | The device is connected to or disconnected from a virtual private network (VPN). |
|  | Preparing internal storage by checking it for errors. |
|  | The RxLogger app is running. |
|  | A ring scanner is connected to the device in HID mode. |

Status Icons

Status icons display system information for the device.

Table 9 Status Icons













| Icon | Description |
|---|------------------------------------|
|  | Alarm is active. |
|  | Main battery is fully charged. |
|  | Main battery is partially drained. |
|  | Main battery charge is low. |
|  | Main battery charge is very low. |
|  | Main battery is charging. |

Table 9 Status Icons (Continued)

| Icon | Description |
|---|---|
|  | All sounds, except media and alarms, are muted. Vibrate mode is active. |
|  | Do Not Disturb mode active. |
|  | Airplane Mode is active. All radios are turned off. |
|  | Bluetooth is on. |
|  | Connected to a Bluetooth device. |
|  | Connected to a Wi-Fi network. Indicates the Wi-Fi version number. |
|  | Not connected to a Wi-Fi network or no Wi-Fi signal. |

Managing Notifications

Notification icons report the arrival of new messages, calendar events, alarms, and ongoing events. When a notification occurs, an icon appears in the Status bar with a brief description.

Figure 9 Quick Settings Bar

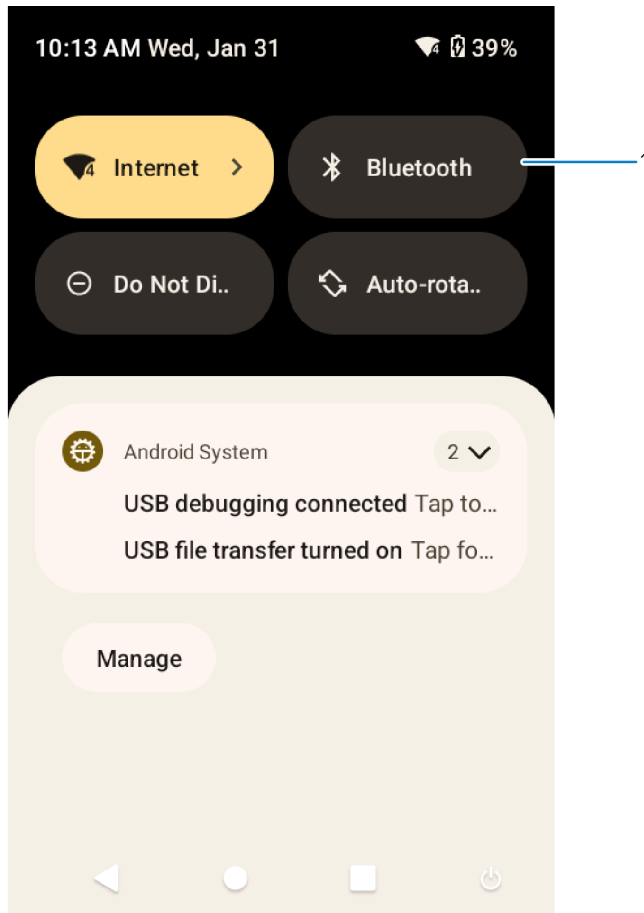

| | |
|---|--------------------|
| 1 | Quick settings bar |
|---|--------------------|

- To view a list of all notifications, open the Notification panel by dragging the Status bar down from the top of the screen.
- To respond to a notification, open the Notification panel and then touch a notification. The Notification panel closes and the corresponding app opens.
- To manage recent or frequently used notifications, open the Notification panel and then touch Manage notifications. Touch the toggle switch next to an app to turn off all notifications, or touch an app for more notification options.
- To clear all notifications, open the Notification panel and then touch **Clear all**. All event-based notifications are removed. Ongoing notifications remain in the list.
- To close the Notification panel, swipe the Notification panel up.

Opening the Quick Access Panel

Use the Quick Access panel to access frequently used settings (for example, Airplane mode).



NOTE: Not all icons are pictured. Icons may vary.

Figure 10 Quick Access Panel

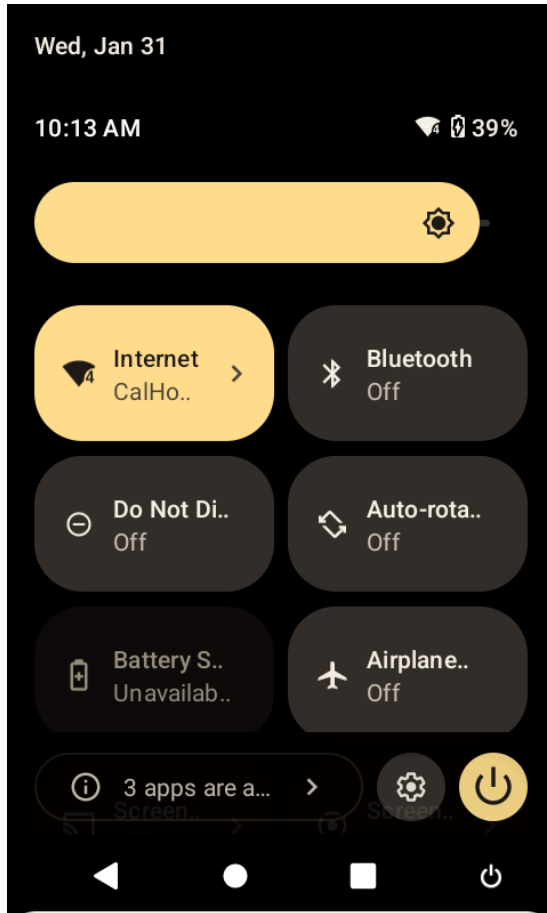













- If the device is locked, swipe down once.
- If the device is unlocked, swipe down once with two fingers, or twice with one finger.
- If the Notification panel is open, swipe down from the Quick Settings bar.

Quick Access Panel Icons

Quick Access panel icons indicate frequently used settings (for example, Airplane mode).

Table 10 Quick Access Panel Icons

| Icon | Description |
|---|---|
|  | Display brightness - Use the slider to decrease or increase the brightness of the screen. |
|  | Internet/Wi-Fi network - Turn Wi-Fi on or off. To open Wi-Fi settings, touch the Wi-Fi network name. |
|  | Bluetooth settings - Turn Bluetooth on or off. To open Bluetooth settings, touch Bluetooth. |
|  | Do not disturb - Control how and when to receive notifications. |
|  | Alarm - Opens the Alarm app. |
|  | Auto-rotate - Lock the device's orientation in portrait or landscape mode or set to automatically rotate. |
|  | Battery saver - Turn Battery saver mode on or off. When Battery saver mode is on the performance of the device is reduced to preserve battery power (not applicable). |
|  | Airplane mode - Turn Airplane mode on or off. When Airplane mode is on the device does not connect to Wi-Fi or Bluetooth. |
|  | Screen Cast - Share phone content on Chromecast or a television with Chromecast built-in. On the Cast screen, check the "enable wireless display" option, and then touch "cast screen" to display a list of devices. Touch a device in the list to begin casting. |
|  | Screen Record - Makes a video recording of everything that happens on the screen, with options to include audio and screen touches. |
|  | NFC - Enable or disable NFC communication. |
|  | Volumehead - Enable to see volume controls on the display. |
|  | Quick Share - Send files to nearby devices when they have the Quick Share feature enabled and their screens on. |

Setting Home Screen Rotation

Screen rotation allows the screen to display vertically or horizontally. By default, screen rotation is disabled on this device.



NOTE: Home screen rotation is available only on Plus SKUs.

1. Touch and hold anywhere on the Home screen until the options appear.
2. Touch **Home settings**.
3. Touch the **Allow Home screen rotation** switch.
4. Touch **Home**.
5. Rotate the device.

Battery Management

Observe the recommended battery optimization tips for the device.

- Set the screen to turn off after a short period of inactivity.
- Reduce screen brightness.
- Turn off all wireless radios when not in use.
- Turn off automatic syncing for Email, Calendar, Contacts, and other apps.
- Minimize the use of apps that keep the device from sleeping, for example, music and video apps.



NOTE: Before checking the battery charge level, remove the device from any AC power source (cradle or cable).

Checking Battery Status

Check the battery status through the Battery Information settings, the Battery Manager app, or the quick access panel.

- Open **Settings** and touch **About phone > Battery Information**. Or swipe up from the bottom of the screen and touch  to open the **Battery Manager** app.

Battery present status indicates if the battery is present.

Battery level lists the battery charge (as a percentage of fully charged).

- Swipe down with two fingers from the status bar to open the quick access panel.

The **battery percentage** is displayed next to the battery icon.

Monitoring Battery Usage

The Battery screen provides battery charge details and power management options to extend battery life. Different apps display different information. Some apps include buttons that open screens with settings to adjust power use.

To display general battery information:

- Touch **Battery**.

- Go to **Settings**.

To display battery information and power management options for a specific app:

- Go to **Settings**.
- Touch **Apps > See all apps**.
- Select an app.
- Touch **App Battery Usage**.
- Use the **DISABLE** or **FORCE CLOSE** buttons to turn off apps that consume too much power.

Low Battery Notification

When the battery charge level drops below the change level in the table below, the device displays a notice to connect the device to power. Charge the battery using one of the charging accessories.

Table 11 Low Battery Notification

| Charge Level Drops Below | Action |
|--------------------------|---|
| 18% | The user should charge the battery soon. |
| 10% | The user must charge the battery. |
| 4% | The device turns off. The user must charge the battery. |

Interactive Sensor Technology

To take advantage of these sensors, applications use API commands. Refer to the Google Android Sensor APIs for more information. For information on the Zebra Android EMDK, go to: techdocs.zebra.com.

The device contains sensors that monitor movement and orientation.

- Gyroscope - Measures angular rotational velocity to detect rotation of the device.
- Accelerometer - Measures the linear acceleration of movement to detect the orientation of the device.
- Proximity Sensor - Detects the presence of nearby objects without physical contact. The sensor detects when the device is close to your face during a call and turns off the screen, preventing unintentional screen touches.
- Magnetometer - Measures the ambient magnetic field to sense the device's orientation in space.
- Barometer - Measures atmospheric pressure and height changes to help track the device's location more accurately.

Waking the Device

The device goes into Suspend mode when you press the Scan key or after a period of inactivity (set in the Display settings window).

1. To wake the device from Sleep mode, press **Power** or the configured wake-up sources.
The Lock screen displays.

2. Swipe the screen up to unlock.

- If the screen option is set to Swipe, the Home screen displays.
- If either the PIN or Password screen unlock feature is enabled, a prompt displays. Enter the PIN or password to unlock the device and move to the Home screen.
- If the Pattern screen unlock feature is enabled, the Pattern screen displays. Swipe the correct pattern between the dots to unlock the device and move to the Home screen.



NOTE: If you enter the PIN, password, or pattern incorrectly five times, you must wait 30 seconds before trying again.

- If you forget the PIN, password, or pattern, contact your system administrator.

USB Communication

Connect the device to a host computer to transfer files between the device and the host computer.

When connecting the device to a host computer, follow the host computer's instructions for connecting and disconnecting USB devices to avoid damaging or corrupting files.

Transferring Files

Use the Transfer files option to copy files between the device and the host computer.

1. Connect the device to a host computer using a USB accessory.
2. On the device, pull down the Notification panel and touch **Charging this device via USB**.
By default, **No data transfer** is selected.
3. Touch **File Transfer**.

Disconnecting from the Host Computer



CAUTION: Carefully follow the host computer's instructions to disconnect USB devices correctly to avoid losing information.



1. On the host computer, unmount the device.
2. Remove the device from the USB accessory.

Settings

This section describes the settings on the device.

Accessing Settings

There are multiple ways to access settings on a device.

- Swipe down with two fingers from the top of the Home screen to open the Quick Access panel and touch .
- Double-swipe down from the top of the Home screen to open the Quick Access panel and touch .
- Swipe up from the bottom of the Home screen to open APPS and touch **Settings**.

Display Settings

Use Display settings to change the screen brightness, enable night light, change the background image, enable screen rotation, set screen timeout, and change font size.

Setting the Screen Brightness Manually

Manually set the screen brightness using the touchscreen.

1. Swipe down with two fingers from the Status bar to open the Quick Access panel.
2. Slide  left or right to adjust the screen brightness level.

Setting Night Light

The Night Light setting tints the screen amber, making the screen easier to look at in low light.

1. Go to **Settings**.
2. Touch **Display**.
3. Touch **Night Light**.
4. Touch **Schedule**.

5. Select one of the schedule values:
 - **None** (default)
 - **Turns on at custom time**
 - **Turns on from sunset to sunrise**
6. **Night Light** is disabled by default. Touch **Use Night Light** to enable.
7. Adjust the tint using the **Intensity** slider.

Setting Screen Rotation

By default, screen rotation is enabled.



NOTE: To change the Home screen rotation, see [Setting Home Screen Rotation](#) on page 40.

1. Go to **Settings**.
2. Touch **Display**.
3. Touch **Auto-rotate screen**.

Setting Screen Timeout

The screen turns off and goes into Suspend mode after the selected period of inactivity.

1. Touch **Settings > Display > Screen Timeout**.
2. Select one of the sleep values:
 - **15 seconds**
 - **30 seconds**
 - **1 minute**
 - **2 minutes**
 - **5 minutes**
 - **10 minutes**
 - **30 minutes**
 - **Never** (default)
3. If desired, turn on the **Screen attention** switch to prevent your screen from turning off while you are looking at it.

Setting Ambient Display

The Ambient display setting wakes the screen when notifications are received.

1. Go to **Settings**.
2. Touch **Display**.
3. Touch **Ambient display**.
4. In the **When to show** section, enable or disable an option using the switch.

Setting Font Size

Set the size of the font in system apps.

1. Go to **Settings**.
2. Touch **Display size and text**. Use the **Font size +** and **-** to vary the font size.
3. Select a font size option:
 - **Small**
 - **Default**
 - **Large**
 - **Largest**

Setting Touch Panel Mode

The device display is able to detect touches using a finger, a conductive-tip stylus, or a gloved finger.



NOTE: A glove can be made of medical latex, leather, cotton, or wool. For optimal performance, use a Zebra-certified stylus.

1. Go to **Settings**.
2. Touch **Display**.
3. Touch **Touch Panel Mode**.

Setting the Date and Time

You are only required to set the time zone or set the date and time if the wireless LAN does not support Network Time Protocol (NTP) or when not connected to a cellular/wireless network.

1. Go to **Settings**.
2. Touch **System > Date & time**
3. Touch **Set time automatically** to disable automatic date and time synchronization.
4. Touch **Set time zone automatically** to disable automatic time-zone synchronization.
5. Touch **Date** to select the date in the calendar.
6. Touch **OK**.
7. Touch **Time**.
 - a) Touch the circle, drag to the current hour, and then release.
 - b) Touch the circle, drag to the current minute, and then release.
 - c) Touch **AM** or **PM**.
8. Touch **OK**.
9. Touch **Use 24-hour format**.

General Sound Settings

Press the volume buttons on the device to display on-screen volume controls.

Use the Sound settings to configure media and alarm volumes.

1. Go to **Settings**.
2. Touch **Sound & Vibrations**.



NOTE: Vibration is available only on Plus SKUs.

3. Touch an option to set sounds.

Sound Options

Use the Sound Options menu to control the type of tone and the volume the device will use for different functions.

- **Media volume** - Controls the music, games, and media volume.
- **Alarm volume** - Controls the alarm clock volume.
- **Notification Volume**- controls notification volume.
- **Do Not Disturb** - Mutes some or all sounds and vibrations.
- **Media** - Touch to open media options.
 - **Pin media player** - touch to show media player in Quick Settings.
 - **Show media on lock screen** - Touch to toggle the media player on the lock screen on and off.
 - **Show media recommendations** Google provides recommendations based on your activity.
- **Default notification sound** - Select a sound to play for all system notifications.
- **Default alarm sound** - Select a sound to play for alarms.
- **Screen locking sound** - Touch to toggle sound on and off.
- **Charging sounds** - Touch to toggle sound on and off.
- **Touch sounds** - Touch to toggle sound on and off.

Keyboards

The device provides multiple keyboard options.

- Android Keyboard - AOSP devices only
- Gboard - GMS devices only
- Enterprise Keyboard



NOTE: By default, the Enterprise and Virtual Keyboards are disabled. The Enterprise Keyboard is available for download from the [Zebra Support Site](#).

Keyboard Configuration

This section describes configuring the device's keyboard.

Enabling Keyboards

Enable the desired keyboard.



1. Go to **Settings**.
2. Touch **System** > **Languages & input** > **On-screen keyboard**.
3. Touch a keyboard to enable it.

Switching Between Keyboards

To switch between keyboards, touch in a text box to display the current keyboard.



NOTE: By default, the Gboard is enabled. All other virtual keyboards are disabled.

- On the Gboard keyboard, touch and hold  (GMS devices only).
- On the Android keyboard, touch, and hold  (AOSP devices only).
- On the Enterprise keyboard, touch . Only available with Mobility DNA Enterprise License. Not pre-installed on the device. Contact Zebra Support for more information.

Using the Android and Gboard Keyboards

Use the Android or Gboard keyboards to enter text in a text field.

- To configure the keyboard settings, touch and hold "," (comma) and then select **Android keyboard settings**.

Edit Text

Edit entered text and use menu commands to cut, copy, and paste text within or across apps. Some apps do not support editing some or all of the text they display; others may offer their own way to select text.

Entering Numbers, Symbols, and Special Characters

1. Enter numbers and symbols.
 - Touch and hold one of the top-row keys until a menu appears then select a number or special character.
 - Touch the Shift key once for a single capital letter. Touch the Shift key twice to lock in uppercase. Touch the Shift key a third time to unlock Capslock.
 - Touch **?123** to switch to the numbers and symbols keyboard.
 - Touch the  key on the numbers and symbols keyboard to view additional symbols.
2. Enter special characters.
 - Touch and hold a number or symbol key to open a menu of additional symbols. A larger version of the key displays briefly over the keyboard.

Enterprise Keyboard

The Enterprise Keyboard contains multiple keyboard types.



NOTE: Only available with Mobility DNA Enterprise License.

- Numeric
- Alpha
- Special characters
- Data capture

Numeric Tab

The numeric keyboard is labeled **123**. The keys displayed vary on the app being used. For example, an arrow displays in **Contacts**, however **Done** displays in **Email** account setup.

Alpha Tab

The alpha keyboard is labeled using the language code. For English, the alpha keyboard is labeled **EN**.

Additional Character Tab

The additional characters keyboard is labeled **#*/**.

- Touch 😊 to enter emoji icons in a text message.
- Touch **ABC** to return to the Symbols keyboard.

Scan Tab

The Scan tab provides an easy data capture feature for scanning barcodes.

Language Usage

Use the **Language & input** settings to change the device's language, including words added to the dictionary.

Changing the Language Setting

1. Go to **Settings**.
2. Touch **System > Languages & input**.
3. Touch **Languages**.
A list of available languages displays.
4. If the desired language is not listed, touch **Add a language** and select a language from the list.
5. Touch and hold **≡** to the right of the desired language, then drag it to the top of the list.
The operating system text changes to the selected language.

Adding Words to the Dictionary

Add frequently-used unique words to the device's dictionary.

1. Go to **Settings**.
2. Touch **System > Languages & input > Personal dictionary**.
3. If prompted, select the language where this word or phrase is stored.
4. Touch + to add a new word or phrase to the dictionary.
5. Enter the word or phrase.
6. In the **Shortcut** text box, enter a shortcut for the word or phrase.

Notifications

Device notification settings allow you to configure how notifications occur on the device, and app notification settings allow you to configure how notifications for a specific app occur.

Device Notification Settings

To view your device notification settings, touch **Settings > Notifications**.

App Notification Settings

To view your app notification settings, go to **Settings > App > All Apps**, and select an app.

Setting App Notifications

Configure the notifications settings for a specific app.

1. Go to **Settings**.
2. Touch **Apps > All Apps**.
3. Select an app.
4. Touch **Notifications**.

Options vary depending on the app selected.

5. Touch the switch to turn on or off notifications for this app.
 - **Allow notification dot** - Do not allow this app to add a notification dot to the app icon.
 - **Additional settings in the app** - Open the app settings.

Viewing Notifications

View and control device notifications to track important device functions and reduce unnecessary distractions.

1. Go to **Settings > Notifications > Apps Settings**.
2. Scroll down to **Notifications** to view how many apps have notifications turned off.

Controlling Lock Screen Notifications

Control whether notifications can be seen when the device is locked.

Go to **Settings > Notifications > Notifications on lock screen** and select one of the following:

- **Show conversations, default, and silent** (default option).
- **Hide silent conversations and notifications.**
- **Don't show any notifications.**

Applications

Apart from the standard pre-installed Android applications, the following table lists Zebra-specific applications installed on the device.

Installed Applications

Aside from the common Google apps, the Zebra-specific apps that are installed on the device are described in this section.

Table 12 Apps















| Icon | Description |
|---|--|
|  | Bluetooth Pairing Utility – Use to pair a Zebra Bluetooth scanner with the device by scanning a barcode. |
|  | Battery Manager - Display battery information, including charge level, status, health and wear level. |
|  | Cradle Firmware Updater - Use to update cradle firmware. |
|  | Cradle Utility - Use to control cradle functionality. |
|  | DataWedge - Enables data capture using the imager. |
|  | DWDemo - Provides a way to demonstrate the data capture features using the imager. |
|  | Enterprise Keyboard - Choose the keyboard that maximizes data entry simplicity for the task at hand with the same familiar swiping motions you use on your personal smartphone. Keyboard layouts include QWERTY, numeric, symbols, phone, and scanning layouts. |

Table 12 Apps (Continued)

| Icon | Description |
|---|--|
|  | License Manager - Use to manage software licenses on the device. |
|  | RxLogger - Use to diagnose device and app issues. |
|  | Settings - Use to configure the device. |
|  | StageNow - Allows the device to stage a device for initial use by initiating the deployment of settings, firmware, and software. |
|  | Wireless Analyzer - A diagnostic intelligent app. Use to diagnose the surrounding area and display network stats, such as coverage hole detection or AP in the vicinity. Refer to the Wireless Analyzer Administrator Guide for Android. Only available with Mobility DNA Enterprise License. |
|  | Zebra Bluetooth Settings - Use to configure Bluetooth logging. |
|  | Zebra Data Services - Use to enable or disable Zebra Data Services. Some options are set by the system administrator. |
|  | Zebra Showcase - Provides a way to experience and learn about Zebra's new or existing capabilities. |

Accessing Apps

Access all apps installed on the device using the APPS window.

1. On the Home screen, swipe up from the bottom of the screen.
2. Slide the **APPS** window up or down to view more app icons.
3. Touch an icon to open the app.

Switching Between Recently Used Apps

Use the Recent button to switch between recently used apps.

1. Touch **Recent**.
A window appears on the screen with icons of recently used apps.
2. Slide the apps displayed up and down to view all recently used apps.

3. Swipe left or right to remove the app from the list and force close the app.
4. Touch an icon to open an app or touch **Back** to return to the current screen.

Battery Manager



The Battery Manager provides detailed information about the battery.

To open the Battery Manager app, swipe up from the bottom of the Home screen, and then touch .

Battery Manager Information

The Battery Manager displays detailed information about battery charging, health, and status.

Table 13 Battery Icons

| Battery Icon | Description |
|---|---|
|  | Battery charge level is between 85% and 100%. |
|  | Battery charge level is between 19% and 84%. |
|  | Battery charge level is between 0% and 18%. |

- **Level** - The current battery charge level as a percentage. Displays -% when the level is unknown.
- **Wear** - The health of the battery in graphical form. When the wear level exceeds 80%, the bar color changes to red.
- **Health** - The health of the battery. If a critical error occurs,  appears. Touch to view the error description.
 - **Decommission** - The battery is past its useful life and should be replaced. See system administrator.
 - **Good** - The battery is good.
 - **Charge error** - An error occurred while charging. See system administrator.
 - **Over Current** - An over-current condition occurred. See system administrator.
 - **Dead** - The battery has no charge. Replace the battery.
 - **Over Voltage** - An over-voltage condition occurred. See system administrator.
 - **Below Temperature** - The battery temperature is below the operating temperature. See system administrator.
 - **Failure Detected** - A failure has been detected in the battery. See system administrator.
 - **Unknown** - See system administrator.

- **Charge Status**
 - **Not charging** - The device is not connected to AC power.
 - **Not charging** - The device is not charging.
 - **Charging-AC** - The device is connected to AC power and charging or is fast charging via USB.
 - **Charging-USB** - The device is connected to a host computer with a USB cable and charging.
 - **Discharging** - The battery is discharging.
 - **Full** - The battery is fully charged.
 - **Unknown** - The battery status is unknown.
- **Time until Full** - The amount of time until the battery is fully charged.
- **Time since charging** - The amount of time since the device began charging.
- **Time until empty** - The amount of time until the battery is empty.
- **Advanced info** - Touch to view additional battery information.
 - **Battery present status** - Indicates that the battery is present.
 - **Battery level** - The battery charge level as a percentage of scale.
 - **Battery scale** - The battery scale level used to determine battery level (100).
 - **Battery voltage** - The current battery voltage in millivolts.
 - **Battery temperature** - The current battery temperature in degrees Centigrade.
 - **Battery technology** - The type of battery.
 - **Battery current** - The average current into or out of the battery over the last second in mAh.
 - **Battery manufacture date** - The date of manufacture.
 - **Battery serial number** - The battery serial number. The number matches the serial number printed on the battery label.
 - **Battery part number** - The battery part number.
 - **Battery rated capacity** - Lists the rated capacity of the backup battery in mAh.
 - **Battery decommission status** - Indicates if the battery is past its life span.
 - **Battery Good** - The battery is in good health.
 - **Decommissioned Battery** - The battery is past its useful life and should be replaced.
 - **Base cumulative charge** - Cumulative charge using Zebra charging equipment only.
 - **Battery usage number** - The health of the battery as a result of charging and discharging. A high number indicates low battery health.
 - **Usage decommission threshold** - When the Battery usage number is greater than or equal to the Usage decommission threshold, the battery is past its useful life and should be replaced.
 - **App version** - The application version number.

Updating Cradle Firmware

The Cradle Firmware Updater app (CradleFWUpdater) allows the manual updating of cradle firmware using the device.

1. Go to the Zebra Support & Downloads website, zebra.com/support, or contact a Zebra Support Representative.
2. Download the MC18CradleFWvx_x firmware file to a host computer.
3. Using Android Debug Bridge (adb) or the sideload process, copy the firmware file to the device.
4. Swipe up from the bottom of the Home screen and touch  CradleFWUpdater.

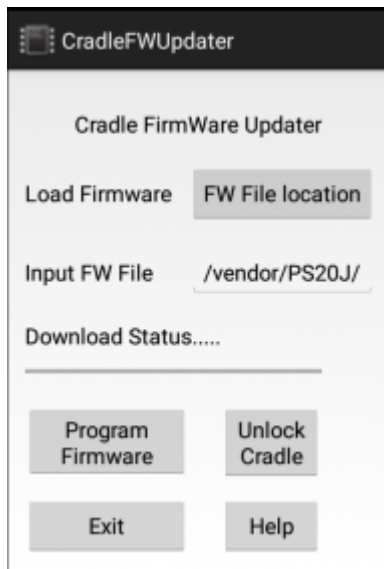

The CradleFWUpdater screen displays.

5. Dock the device in the cradle.
6. Select the FW File location.
The Files app opens.
7. Navigate to the appropriate HEX firmware file and then touch **OK**.
The path of the selected file displays in the Input FW File text box.
8. Verify the filename and extension.
9. Touch **Program Firmware**.

A warning dialog displays, **Please don't remove device from cradle until FW Update complete. Continue?**

10. Touch **OK** to initiate the firmware update process.



NOTE: During the firmware initiation process, the application resets the cradle. If the following error dialog displays: **Please manually reset the cradle and then press OK**, you must manually reset the cradle.

To manually reset the cradle:

- a) Disconnect power from the power supply unit of the cradle.
- b) Reconnect power to the power supply unit of the cradle.
- c) Touch **OK** within 10 seconds after power on and before the LEDs on the cradle start glowing to continue.

Failing to touch **OK** before the LEDs starts glowing will cause the app to redisplay the error message. If this fails twice, the firmware update process stops. If the app is successful, it starts the downloading process.

After resetting the cradle, the app starts the firmware download process.

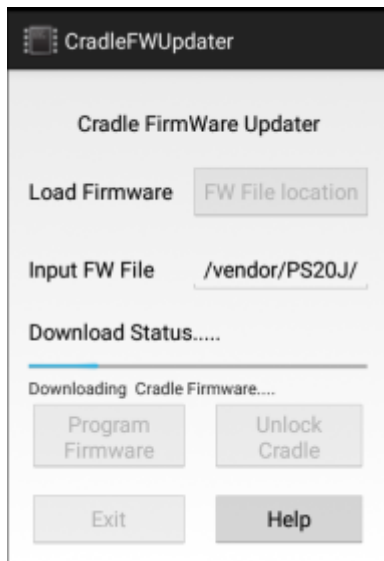

IMPORTANT: Do not attempt to disconnect power from the cradle or remove the device from the cradle during a cradle firmware update. Removing the device while the firmware is updating would result in an incomplete firmware update, leaving the cradle with partial firmware. To recover from the situation of partially downloaded firmware, open the Cradle Firmware Updater app and perform a manual reset of the cradle power when alerted.

When the **Update Completed** message displays, the firmware update process is complete.

11. Touch **OK** to exit the message.

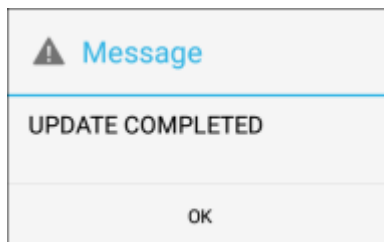

12. Touch **Unlock Cradle** to unlock and remove the device from the cradle.

13. Touch **Help** for app information and instructions for using the app.

Sending the File Using the Recovery Method

1. Put the device in Recovery Mode. Go to [Entering into Recovery Mode](#) for more information.
2. Select **Update via adb > FullPackageUpdate**.
3. Enter the following at a command prompt:

```
adb sideload <packagename>
```

4. Reboot the device.



NOTE: It is also possible to use MDM to update Cradle Firmware through a recovery package.

Cradle Utility

The Cradle Utility controls the functions and information pertaining to the cradle.

Use the Cradle Utility to:

- Perform cradle operations (for example, unlock cradle or set LED)
- Configure cradle information (for example, Row ID or Column ID)
- Read the cradle manufacturing information
- Read the cradle diagnostics information.

Controlling the Cradle

Tap the **CRADLE UNLOCK** tab to set the cradle unlocking information.

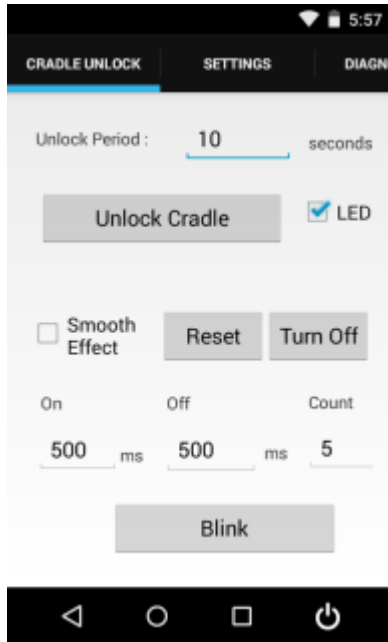

- Modify these settings as desired:
 - **Unlock Period:** The duration in seconds for which the device remains in unlocked state (if not removed from the cradle). For example; if unlock period is set to 15 and unlock signal is received, the device will unlock and lock back after 15 seconds (if its not removed by user).
 - **Unlock Cradle:** Press Unlock Cradle to manually unlock the device from the cradle.
 - **LED:** Check the LED box to enable the cradle LED indication.
 - **Smooth Effect:** Check the Smooth Effect box to enable smooth blinking of the LEDs.
 - **LED Setting > On:** The duration (in ms) that the cradle LED remains turned on or blinks during unlock.
 - **LED Setting > Off:** The duration (in ms) that the cradle LED remains turned off or blinks during unlock.
 - **LED Setting > Count:** The number of times the cradle LED blinks when user presses the blink button.
 - **Blink:** Tap to test the cradle LED operation.

Setting the Cradle

The Cradle Utility allows you to manually enter cradle settings. To automatically enter cradle settings, use the optional Smart Cradle Configuration app (CradleSmartConfig).

Setting the cradle charging rate: Depending on the cradle installation configuration, the store technician can configure each individual cradle slot to enable/disable fast charge. Each cradle can be configured to charge its docked terminal at 1 A (normal charging mode - default setting) or 1.5 A (fast charging mode).



NOTE: The cradle charging rate is retained across firmware upgrades.

Tap the **SETTINGS** tab to set the cradle information.

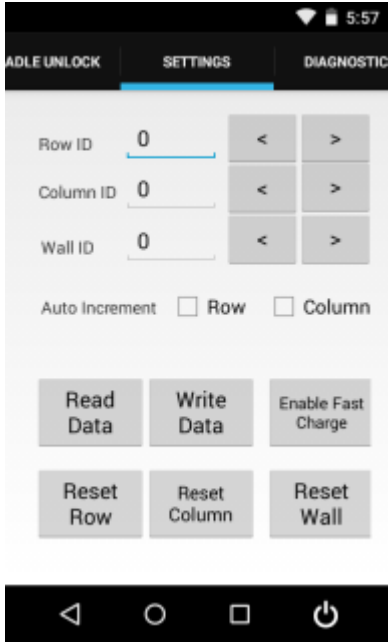

- Modify these settings as desired:
 - **Row ID:** The cradle row number in the dispenser wall.
 - **Column ID:** The cradle column number in the dispenser wall.
 - **Wall ID:** The number of dispenser wall where the cradle is positioned.
 - **Read Data:** Retrieve setting data from the cradle memory and display on the screen.
 - **Write Data:** Tap this button to program the row/col/wall information onto the cradle. Note that each slot on the Three Slot Cradle needs to be programmed separately.
 - **Enable Fast Charge:** Enable the cradle to charge the device at a current of 1.5 A (default setting is 1 A)
 - **Reset Row:** Tap to update the Row ID in the text field to “0” on the application.
 - **Reset Column:** Tap to update the Column ID in the text field to “0” on the application.
 - **Reset Wall:** Tap to update the Wall ID in the text field to “0” on the application.

Performing Cradle Diagnostics

Touch the **DIAGNOSTICS** tab to perform cradle diagnostics.

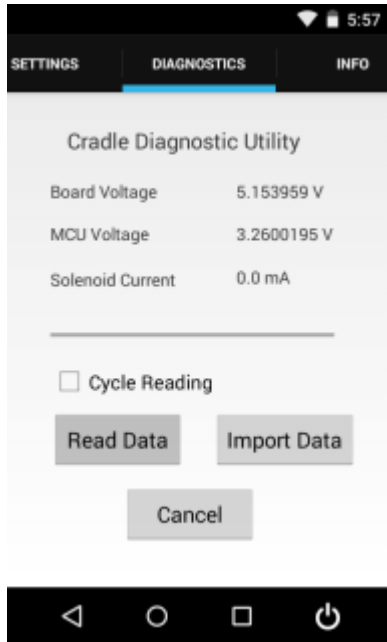

- Modify these settings as desired:
 - **Cycle Reading:** Check the Cycle Reading box to perform continuous diagnostics and display the cradle status information. During diagnostics, a progress bar is shown on the screen.
 - **Read Data:** Tap to start performing diagnostics.
 - **Import Data:** Tap to save the recorded results of the diagnostics on a file.

Viewing Cradle Information

To view cradle information, touch the **INFO** tab.

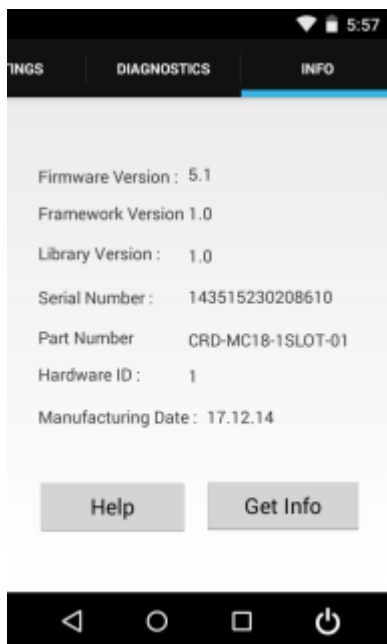

DataWedge Demonstration

Use DataWedge Demonstration (DWDemo) to demonstrate data capture functionality. To configure DataWedge, refer to techdocs.zebra.com/datawedge/.











NOTE: DataWedge is enabled on the Home screen. To disable this feature, go to the DataWedge settings and disable the **Launcher** profile.

DataWedge Demonstration Icons

These icons display DataWedge information.

Table 14 DataWedge Demonstration Icons

| Item | Icon | Description |
|--------------|---|---|
| Illumination |  | Imager illumination is on. Touch to turn illumination off. |
| Illumination |  | Imager illumination is off. Touch to turn illumination on. |
| Data Capture |  | The data capture function is through the internal imager. |
| Data Capture |  | An RS6000 Bluetooth imager is connected. |
| Data Capture |  | An RS6000 Bluetooth imager is not connected. |
| Scan Mode |  | Imager is in picklist mode. Touch to change to normal scan mode. |
| Scan Mode |  | Imager is in normal scan mode. Touch to change to picklist mode. |
| Menu |  | Opens a menu to view the application information or to set the application DataWedge profile. |

Selecting a Scanner

See the Data Capture section for more information.

1. To select a scanner, touch  > **Settings** > **Scanner Selection**.
2. Press the programmable button or touch the yellow scan button to capture data.
The data appears in the text field below the yellow button.

RxLogger

RxLogger is a comprehensive diagnostic tool that provides application and system metrics, and diagnoses device and application issues.

RxLogger logs the following information: CPU load, memory load, memory snapshots, battery consumption, power states, wireless logging, TCP dumps, Bluetooth logging, logcat, FTP push/pull, ANR dumps, etc. All generated logs and files are saved onto flash storage on the device (internal or external).

RxLogger Configuration

RxLogger is built with an extensible plug-in architecture and comes packaged with a number of plug-ins already built-in. For information on configuring RxLogger, refer to techdocs.zebra.com/rxlogger/.

To open the configuration screen, from the RxLogger home screen, touch **Settings**.

Configuration File

All RxLogger settings are stored in a file on the device, permitting remote configuration and mass deployment of setting files using an enterprise mobile management (EMM) system.



IMPORTANT: The RxLogger configuration file is human-readable; however, it should not be edited by hand as doing so can lead to unpredictable behavior. Zebra recommends modifying RxLogger settings only through the RxLogger UI.

- File name: `config.json`
- Location: `/<internal_storage>/RxLogger`

Copy the file from the device to a host computer using a USB connection. Edit the configuration file through the RxLogger UI and then replace the JSON file on the device. There is no need to stop and restart the RxLogger service because the file change is automatically detected.

Enabling Logging

1. Swipe the screen up and select .
2. Touch **Start**.

Disabling Logging

1. Swipe the screen up and select .
2. Touch **Stop**.

Extracting Log Files

1. Connect the device to a host computer using a USB connection.
2. Using a file explorer, navigate to the RxLogger folder.
3. Copy the file from the device to the host computer.
4. Disconnect the device from the host computer.

Backing Up Data

RxLogger Utility allows the user to make a zip file of the RxLogger folder in the device, which by default contains all the RxLogger logs stored in the device.

- To save the backup data, touch  > **BackupNow**.

RxLogger Utility

RxLogger Utility is a data monitoring application for viewing logs in the device while RxLogger is running. Logs and RxLogger Utility features are accessed using Main Chat Head.

Initiating the Main Chat Head

1. Open **RxLogger**.
2. Touch  > **Toggle Chat Head**.
The Main Chat Head icon appears on the screen.
3. Touch and drag the Main Chat Head icon to move it around the screen.

Removing the Main Chat Head

1. Touch and drag the icon.
A circle with an X appears.
2. Move the icon over the circle and then release.

Viewing Logs

1. Touch the Main Chat Head icon.
The RxLogger Utility screen displays.
2. Touch a log to open it.
Open many logs with each displaying a new Sub Chat Head.
3. If necessary, scroll left or right to view additional Sub Chat Head icons.
4. Touch a Sub Chat Head to display the log contents.

Removing a Sub Chat Head Icon

- To remove a Sub Chat Head icon, press and hold the icon until it disappears.

Backing Up In Overlay View

RxLogger Utility allows the user to make a zip file of the RxLogger folder in the device, which by default contains all the RxLogger logs stored in the device.

The Backup icon is always available in Overlay View.

1. Touch .
The Backup dialog box appears.

2. Touch **Yes** to create the backup.

Data Capture

This section provides information for capturing barcode data using various scanning options.

The imager, which allows the collection of data by scanning barcodes, has the following features

- It reads a variety of barcode symbologies, including the most popular linear, postal, and 2-D code types.
- It contains an advanced, intuitive aiming light for easy point-and-shoot operation.



NOTE: Bluetooth scanners are not supported.

The device supports data capture using the integrated SE4710 Imager

Scanning Considerations

Typically, scanning is a simple matter of aim, scan, and decode, with a few quick trial efforts to master it.

However, consider the following to optimize scanning performance:

- **Range** — Scanners decode optimally over a particular working range — minimum and maximum distances from the barcode. This range varies according to barcode density and scanning device optics. Scan within range for quick and constant decodes; scanning too close or too far away prevents decodes. Move the scanner closer and further away to find the right working range for the barcodes being scanned.
- **Angle** — Scanning angle is important for quick decodes. When the illumination/flash reflects directly back into the imager, the specular reflection can blind/saturate the imager. To avoid this, scan the barcode so that the beam does not bounce directly back. Do not scan at too sharp an angle; the scanner needs to collect scattered reflections from the scan to make a successful decode. Practice quickly shows what tolerances to work within.
- Hold the device farther away for larger symbols.
- Move the device closer for symbols with bars that are close together.



NOTE: Scanning procedures depend on the app and device configuration. An app may use different scanning procedures from the one listed above.

Scanning Barcodes

Use the PS30 personal shopper to capture barcode data.



NOTE: To read a barcode, a scan-enabled app is required. The device contains the DataWedge app, which allows you to enable the scanner to decode barcode data and display the barcode content.

1. Launch a scanning application.
2. Press the Scan key and aim the device at a barcode.
A red aiming dot, used for increased visibility in bright lighting conditions, displays.
3. Adjust the position of the device so that the red aiming dot appears at the center of the barcode.
Ensure that the barcode is within the area formed by the aiming pattern.

Figure 11 SE4710 Imager Decode Mode

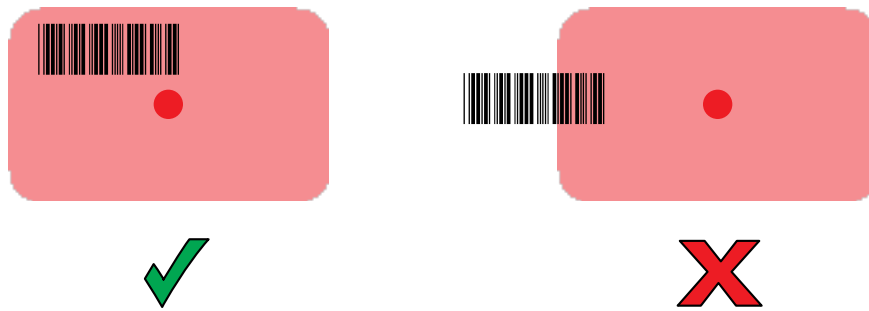
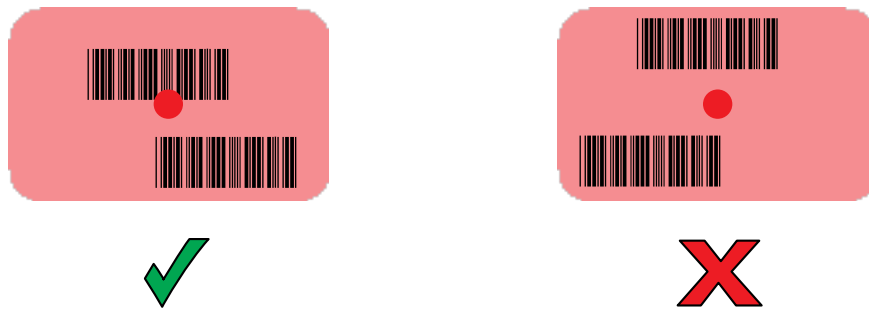

Figure 12 SE4710 Imager Picklist Mode



NOTE: When the PS30 is in Picklist Mode, the imager does not decode the barcode until the crosshair or aiming dot touches the barcode.

4. Release the Scan key.
The barcode data displays on the screen.

Decode Screen Notification

Display a translucent green screen overlay as a notification for each successful decode.

Scan Params in DataWedge includes an option for **Decode Screen Notification**. Enable this option to display a translucent green screen overlay as a notification for each successful decode. In addition, Scan

Params includes options for **Decode Screen Notification Timer** and **Decode Screen Translucency Level**, which allow you to set the green screen overlay time in milliseconds and change the level of translucency.



NOTE: For **Decode Screen Notification** to work, **Display over other apps** permission must be granted for the application.

Figure 13 Translucent Green Overlay Decode Screen Notification



Hands-Free Scanning

Hands-Free Scanning allows the user to capture barcode data when a barcode is placed within the view of the device without pressing the trigger.

Hands-Free Scanning is enabled using the **Hands Free Trigger** settings or when the device is placed in the cart/mount. Hands-Free Scanning is set to disabled by default.

Settings

Use the Hands-Free Trigger setting to configure scanning mode and the proximity trigger sensitivity.

Swipe down from the Status bar to open the Quick Access panel and then touch  > **Hands-Free Trigger** .

Figure 14 Hands-Free Trigger Settings

← Hands Free Trigger

Scanning Mode
Hands Free Off

Proximity Trigger Range
Near

Scanning Mode

Use the **Scanning Mode** settings to configure how the device functions while in hands free scanning mode.

Figure 15 Scanning Mode Dialog Box

Scanning Mode

Hands Free in Cart/
Mount

Hands Free Always On

Hands Free Off

CANCEL



NOTE: To use the **Hands Free in Cart/Mount** scanning mode, the devices in a store must be calibrated to the cart orientation first. A properly calibrated device with hands-free scanning mode enabled detects when it has been placed in a cart and automatically enables the hands-free trigger. While in the cart, the device displays a shopping cart notification in the status bar.

- **Hands Free in Cart/Mount** - Select to enable scanning when the device is in the cart/mount. The device detects the difference between in-motion and stationary states. When the device is in the Motion state, proximity scanning is disabled. When the device is in the Stationary state or in a hands free cart/mount, proximity scanning is enabled.
- **Hands Free Always On** - Select to place the device in hands free scanning mode.
- **Hands Free Off** - Select to disable hands free scanning mode (default).

Proximity Range

To configure the proximity sensor range sensitivity, touch **Proximity Trigger Range**.

Figure 16 Proximity Trigger Range Dialog Box

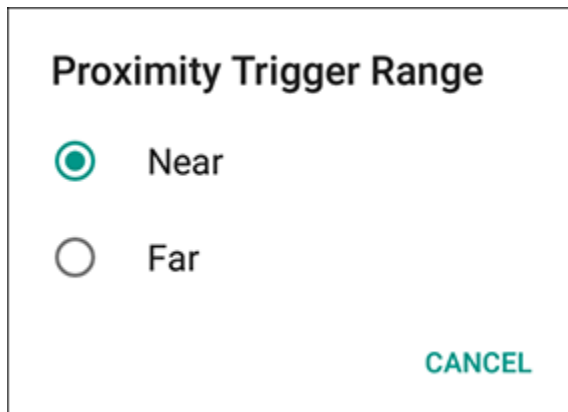

- **Near** — Proximity sensor detects and generates a trigger when the barcode is within 0 to 15 cm (nominal) (default). Ideally, 0-5 in (approx. 13 cm) is supported.
- **Far** — Proximity sensor detects and generates a trigger when the barcode is within 0 to 26 cm (nominal). The maximum range is 10 in (approx. 26 cm).

DataWedge

DataWedge is a utility that adds advanced barcode scanning capability to any application without writing code. It runs in the background and handles the interface to built-in barcode scanners. The captured barcode data is converted to keystrokes and sent to the target application as if it was typed on the keypad.

DataWedge allows any app on the device to get data from input sources such as a barcode scanner, MSR, RFID, voice, or serial port and manipulate the data based on options or rules.



Configure DataWedge to:

- Provide data capture services from any app.
- Use a particular scanner, reader, or other peripheral devices.
- Properly format and transmit data to a specific app.

To configure DataWedge, refer to techdocs.zebra.com/datawedge/.

Enabling DataWedge



This procedure provides information on how to enable DataWedge on the device.

1. Swipe up from the bottom of the Home screen and touch .
2. Touch  > **Settings**.
3. Touch the **DataWedge enabled** checkbox.

A blue checkmark appears in the checkbox indicating that DataWedge is enabled.

Disabling DataWedge

This procedure provides information on how to disable DataWedge on the device.

1. Swipe up from the bottom of the Home screen and touch .
2. Touch .
3. Touch **Settings**.
4. Touch **DataWedge enabled**.

Supported Decoders

This sections provides the supported decoders for each data capture option.

SE4710 Internal Imager Supported Decoders

This section lists the supported decoders for the SE4710 internal imager.

Table 15 Internal Imager SE4710 Supported Decoders

| Decoder | Default State | Decoder | Default State | Decoder | Default State |
|-------------------|---------------|----------------------|---------------|-------------------|---------------|
| Australian Postal | O | EAN8 | X | MSI | O |
| Aztec | X | Grid Matrix | O | PDF417 | X |
| Canadian Postal | O | GS1 DataBar | X | QR Code | X |
| Chinese 2 of 5 | O | GS1 DataBar Expanded | X | Decoder Signature | O |
| Codabar | X | GS1 DataBar Limited | O | TLC 39 | O |
| Code 11 | O | GS1 Datamatrix | O | Trioptic 39 | O |
| Code 128 | X | GS1 QRCode | O | UK Postal | O |
| Code 39 | X | HAN XIN | O | UPCA | X |
| Code 93 | O | Interleaved 2 of 5 | O | UPCE0 | X |
| Composite AB | O | Japanese Postal | O | UPCE1 | O |

Table 15 Internal Imager SE4710 Supported Decoders (Continued)

| Decoder | Default State | Decoder | Default State | Decoder | Default State |
|-----------------|---------------|---------------|---------------|---------------|---------------|
| Composite C | O | Korean 3 of 5 | O | US4state | O |
| Discrete 2 of 5 | O | MAIL MARK | X | US4state FICS | O |
| Datamatrix | X | Matrix 2 of 5 | O | US Planet | O |
| Dutch Postal | O | Maxicode | X | US Postnet | O |
| DotCode | O | MicroPDF | O | | |
| EAN13 | X | MicroQR | O | | |

Key: X = Enabled, O = Disabled, - = Not Supported

Wireless

This section provides information on the wireless features of the device.

The following wireless features are available on the device:

- Wireless Local Area Network (WLAN)
- Bluetooth
- Cast

Wireless Local Area Networks

Wireless local area networks (WLANs) allow the device to communicate wirelessly inside a building. Before using the device on a WLAN, the facility must be set up with the required hardware to run the WLAN (sometimes known as infrastructure). The infrastructure and the device must both be properly configured to enable this communication.

Refer to the documentation provided with the infrastructure (access points (APs), access ports, switches, Radius servers, etc.) for instructions on how to set up the infrastructure.

After the infrastructure is set up to enforce the chosen WLAN security scheme, use **Network & internet** to open settings and configure the device to match the security scheme.

The device supports the following WLAN options:

- Open
- Wireless Equivalent Privacy (WEP)
- Wi-Fi Protected Access (WPA)/WPA2 Personal (PSK)
- WPA/WPA2-Enterprise
 - Protected Extensible Authentication Protocol (EAP_ with MSCHAPV2 and GTC authentication
 - Transport Layer Security (TLS)
 - Tunneled Transport Layer Security (TTLS) with Password Authentication Protocol (PAP) with SCHAP and MSCHAPv2 authentication and GTC authentication.
 - Password (PWD).
 - Extensible Authentication Protocol Method for Subscriber Identity Module (SIM)
 - Extensible Authentication Protocol Method for Authentication and Key Agreement (AKA)
 - Improved Extensible Authentication Protocol Method for Authentication and Key Agreement (AKA')
 - Lightweight Extensible Authentication Protocol (LEAP).

- WPA3-Enterprise 192-bit
- WPA3-Enterprise
 - Protected Extensible Authentication Protocol (PEAP) - with MSCHAPV2 and GTC authentication.
 - Transport Layer Security (TLS)
 - Tunneled Transport Layer Security (TTLS) - with Password Authentication Protocol (PAP) with MSCHAP and MSCHAPv2 authentication, and GTC authentication.
 - Password (PWD)
 - Extensible Authentication Protocol Method for Subscriber Identity Module (SIM)
 - Extensible Authentication Protocol Method for Authentication and Key Agreement (AKA)
 - Improved Extensible Authentication Protocol Method for Authentication and Key Agreement (AKA')
 - Lightweight Extensible Authentication Protocol (LEAP)

The **Status** bar displays icons that indicate Wi-Fi network availability and Wi-Fi status.



NOTE: To extend the life of the battery, turn off Wi-Fi when not in use.

Connecting to a Wi-Fi Network

Most of the device's functionality requires an internet connection. Connect to an available Wi-Fi network to use the device features.

1. Go to **Settings**.
2. Touch **Network & internet**.
3. Touch **Internet** to open the **Internet** screen. The device searches for WLANs in the area and lists them.
4. Scroll through the list and select the desired WLAN network.
5. For open networks, touch the profile once or press and hold and then select **Connect** or for secure networks, enter the required password or other credentials, then touch **Connect**. See the system administrator for more information.

The device obtains a network address and other required information from the network using the dynamic host configuration protocol (DHCP) protocol. To configure the device with a fixed internet protocol (IP) address, see [Configuring the Device to Use a Static IP Address](#).

In the Wi-Fi setting field, **Connected** appears, indicating that the device is connected to the WLAN.

Removing a Wi-Fi Network

Remove a remembered or connected Wi-Fi network.

1. Go to **Settings**.
2. Touch **Network & Internet**.
3. Touch **Internet**.
4. Scroll down to the bottom of the list and touch **Saved networks**.
5. Touch the name of the network.
6. Touch **FORGET**.

WLAN Configuration

This section provides information on configuring Wi-Fi settings.

Configuring a Secure Wi-Fi Network

Use the internet settings to set up the correct secure Wi-Fi connection.

1. Go to **Settings**.
2. Touch **Network & Internet > Internet**.
3. Slide the switch to the **ON** position.
The device searches for WLANs in the area and lists them on the screen.
4. Scroll through the list and select the desired WLAN network.
5. Touch the desired network. If network security is **Open**, the device automatically connects to the network. For all other network security, a dialog box appears.
6. If network security is **WPA/WPA2-Personal**, **WPA3-Personal**, or **WEP**, enter the required password and then touch **Connect**.
7. If network security is **WPA/WPA2/WPA3 Enterprise**:
 - a) Touch the **EAP method** drop-down list and select one of the following:
 - **PEAP**
 - **TLS**
 - **TTLS**
 - **PWD**
 - **LEAP**
 - b) Fill in the appropriate information. Options vary depending on the **EAP method** chosen.
 - When selecting **CA certificate**, Certification Authority (CA) certificates are installed using the **Security** settings.
 - When using the EAP methods PEAP, TLS, or TTLS, specify a domain.
 - Touch **Advanced options** to display additional network options.
8. If the network security is **WPA3-Enterprise 192-bit**:
 - Touch **CA certificate** and select a Certification Authority (CA) certificate. Note: Certificates are installed using the Security settings.
 - Touch **User certificate** and select a user certificate. Note: User certificates are installed using the Security settings.
 - In the **Identity** text box, enter the username credentials.



NOTE: By default, the network Proxy is set to None and the IP settings is set to DHCP. Go to [Configuring for a Proxy Server](#) on page 76 for setting the connection to a proxy server and go to [Configuring the Device to Use a Static IP Address](#) for setting the device to use a static IP address.

9. Touch **Connect**.

Manually Adding a Wi-Fi Network

Manually add a Wi-Fi network if the network does not broadcast its name (SSID) or to add a Wi-Fi network when out of range.

1. Go to **Settings**.
2. Touch **Network & Internet > Internet**.
3. Slide the Wi-Fi switch to the **On** position.
4. Scroll to the bottom of the list and select **Add network**.
5. In the **Network name** text box, enter the name of the Wi-Fi network.
6. In the **Security** drop-down list set the type of security to:
 - **None**
 - **Enhanced Open**
 - **WEP**
 - **WPA/WPA2-Personal**
 - **WPA3-Personal**
 - **WPA/WPA2-Enterprise**
 - **WPA-Enterprise**
 - **WPA3-Enterprise 192-bit**
7. If the network security is **None** or **Enhanced Open**, touch **Save**.
8. If the network security is **None**, touch **Save**.
9. If the network security is **WEP**, **WPA3-Personal**, or **WPA/WPA2-Personal**, enter the required password and then touch **Save**.
10. If network security is **WPA/WPA2/WPA3 Enterprise**:
 - a) Touch the **EAP method** drop-down list and select one of the following:
 - **PEAP**
 - **TLS**
 - **TTLS**
 - **PWD**
 - **LEAP**
 - b) Fill in the appropriate information. Options vary depending on the **EAP method** chosen.
 - When selecting **CA certificate**, Certification Authority (CA) certificates are installed using the **Security** settings.
 - When using the EAP methods PEAP, TLS, or TTLS, specify a domain.
 - Touch **Advanced options** to display additional network options.

11. If the network security is WPA3-Enterprise 192-bit:
 - Touch **CA certificate** and select a Certification Authority (CA) certificate. Note: Certificates are installed using the Security settings.
 - Touch **User certificate** and select a user certificate. Note: User certificates are installed using the Security settings.
 - In the **Identity** text box, enter the username credentials.



NOTE: By default, the network Proxy is set to None and the IP settings is set to DHCP. Go to [Configuring for a Proxy Server](#) on page 76 for setting the connection to a proxy server and go to [Configuring the Device to Use a Static IP Address](#) for setting the device to use a static IP address.

12. Touch **Save**. To connect to the saved network, touch and hold on the saved network and select **Connect to network**.

Configuring for a Proxy Server

A proxy server is a server that acts as an intermediary for requests from clients seeking resources from other servers. A client connects to the proxy server and requests some service, such as a file, connection, web page, or other resource, available from a different server. The proxy server evaluates the request according to its filtering rules. For example, it may filter traffic by IP address or protocol. If the request is validated by the filter, the proxy provides the resource by connecting to the relevant server and requesting the service on behalf of the client.

It is important for enterprise customers to be able to set up secure computing environments within their companies, making proxy configuration essential. Proxy configuration acts as a security barrier ensuring that the proxy server monitors all traffic between the Internet and the intranet. This is normally an integral part of security enforcement in corporate firewalls within intranets.

1. Go to **Settings > Network & Internet**.
2. Touch **Internet**.
3. Slide the Wi-Fi switch to the **On** position.
4. In the network dialog box, select and touch a network.
5. If configuring the connected network, touch  to edit the network details and then touch the down arrow to hide the keyboard.
6. Touch **Advanced options**.
7. Touch **Proxy** and select **Manual**.
8. In the **Proxy hostname** text box, enter the address of the proxy server.
9. In the **Proxy port** text box, enter the port number for the proxy server.
10. In the **Bypass proxy for** text box, enter addresses for web sites that are not required to go through the proxy server. Use a comma “,” between addresses. Do not use spaces or carriage returns between addresses.
11. If configuring the connected network, touch **Save** otherwise, touch **Connect**.
12. Touch **Connect**.

Configuring the Device to Use a Static IP Address

By default, the device is configured to use Dynamic Host Configuration Protocol (DHCP) to assign an Internet protocol (IP) address when connecting to a wireless network.

1. Go to **Settings**.
2. Touch **Network & Internet > Internet**.
3. Slide the Wi-Fi switch to the **On** position.
4. In the network dialog box, select and touch a network.
5. If configuring the connected network, touch  to edit the network details and then touch the down arrow to hide the keyboard.
6. Touch **Advanced options**.
7. Touch **IP settings** and select **Static**.
8. In the **IP address** text box, enter an IP address for the device.
9. If required, in the **Gateway** text box, enter a gateway address for the device.
10. If required, in the **Network prefix length** text box, enter the prefix length.
11. If required, in the **DNS 1** text box, enter a Domain Name System (DNS) address.
12. If required, in the **DNS 2** text box, enter a DNS address.
13. If configuring the connected network, touch **Save** otherwise, touch **Connect**.

Wi-Fi Preferences

Use the Wi-Fi preferences to configure advanced Wi-Fi settings. From the Wi-Fi screen, scroll down to the bottom of the screen and touch Wi-Fi preferences.

- **Turn on Wi-Fi automatically** - When enabled, Wi-Fi automatically turns back on when near high-quality saved networks.
- **Open network notification** - When enabled, notify the user when an open network is available.
- **Notify for public networks** - When enabled, notify the user when an open network is available.
- **Advanced** - Touch to expand options.
 - **Additional settings** - Touch to view additional Wi-Fi settings.
 - **Install Certificates** - Touch to install certificates.
 - **Network rating provider** - Disabled (AOSP devices). To help determine what constitutes a good Wi-Fi network, Android supports external Network rating providers that provide information about the quality of open Wi-Fi networks. Select one of the providers listed or **None**. If none are available or selected, the Connect to open networks feature is disabled.
 - **Wi-Fi Direct** - Displays a list of devices available for a direct Wi-Fi connection.

Additional Wi-Fi Settings

Use the Additional Settings menu to configure additional Wi-Fi settings.



NOTE: Additional Wi-Fi settings are for the device, not for a specific wireless network.

- **Regulatory**
 - **Country Selection** - Displays the acquired country code if 802.11d is enabled, else it displays the currently selected country code.
 - **Region code** - Displays the current region code.
- **Band and Channel Selection**
 - **Wi-Fi frequency band** - Set the frequency band to: **Auto** (default), **6 GHz only**, **5 GHz only**, or **2.4 GHz only**.
 - **Available channels (2.4 GHz)** - Touch to display the **Available channels** menu. Select specific channels and touch **OK**.
 - **Available channels (5 GHz)** - Touch to display the **Available channels** menu. Select specific channels and touch **OK**.
 - **Available channels (6 GHz)** - Touch to display the **Available channels** menu. Select specific channels and touch **OK**.
- **Logging**
 - **Advanced Logging** - Touch to enable logging, enable Wi-Fi Verbose Logging, or change the log directory.
 - **Wireless logs** - Use to capture Wi-Fi log files.
 - **Fusion Logger** - Touch to open the **Fusion Logger** application. This application maintains a history of high-level WLAN events, which helps to understand the status of connectivity.
 - **Fusion Status** - Touch to display the live status of the WLAN state. Also provides information about the device and connected profile.
- **About**
 - **Version** - Displays the current version information. Touch the version to display addition version details.

Wi-Fi Direct

Wi-Fi Direct devices can connect to each other without having to go through an access point. Wi-Fi Direct devices establish their own ad-hoc network when required, letting you see which devices are available and choose which one to connect to.

1. Go to **Settings > Network & internet**.
The device searches for another Wi-Fi Direct device.
2. Touch **Internet > Network preferences > Wi-Fi Direct**.
The device searches for another Wi-Fi Direct device.
3. Under **Peer devices**, touch the other device's name.

4. On the other device, select **Accept**.

Connected appears on the device. On both devices, in their respective Wi-Fi Direct screens, the other device name appears in the list.

Bluetooth

Bluetooth devices can communicate without wires, using frequency-hopping spread spectrum (FHSS) radio frequency (RF) to transmit and receive data in the 2.4 GHz Industry Scientific and Medical (ISM) band (802.15.1). Bluetooth wireless technology is specifically designed for short-range (10 m (32.8 ft)) communication and low power consumption.

Devices with Bluetooth capabilities can exchange information (for example, files, appointments, and tasks) with other Bluetooth enabled devices such as printers, access points, and other mobile devices.

The device supports Bluetooth Low Energy. Bluetooth Low Energy is targeted at applications in the healthcare, fitness, security, and home entertainment industries. It provides reduced power consumption and cost while maintaining standard Bluetooth range.

Adaptive Frequency Hopping

Adaptive Frequency Hopping (AFH) is a method of avoiding fixed frequency interferers, and can be used with Bluetooth voice. All devices in the piconet (Bluetooth network) must be AFH-capable in order for AFH to work. There is no AFH when connecting and discovering devices. Avoid making Bluetooth connections and discoveries during critical 802.11b communications.

- Channel Classification - A method of detecting an interference on a channel-by-channel basis, or pre-defined channel mask.
- Link Management - Coordinates and distributes the AFH information to the rest of the Bluetooth network.
- Hop Sequence Modification - Avoids interference by selectively reducing the number of hopping channels.
- Channel Maintenance - A method for periodically re-evaluating the channels.

When AFH is enabled, the Bluetooth radio “hops around” (instead of through) the 802.11b high-rate channels. AFH coexistence allows enterprise devices to operate in any infrastructure.

The Bluetooth radio in this device operates as a Class 2 device power class. The maximum output power is 2.5 mW and the expected range is 10 m (32.8 ft). A definition of ranges based on power class is difficult to obtain due to power and device differences, and whether in open space or closed office space.



NOTE: It is not recommended to perform Bluetooth wireless technology inquiry when high rate 802.11b operation is required.

Security

The current Bluetooth specification defines security at the link level. Application-level security is not specified. This allows application developers to define security mechanisms tailored to their specific needs. Link-level security occurs between devices, not users, while application-level security can be implemented on a per-user basis. The Bluetooth specification defines security algorithms and procedures required to authenticate devices, and if needed, encrypt the data flowing on the link between the devices. Device authentication is a mandatory feature of Bluetooth while link encryption is optional.

Pairing of Bluetooth devices is accomplished by creating an initialization key used to authenticate the devices and create a link key for them. Entering a common personal identification number (PIN) in the devices being paired generates the initialization key. The PIN is never sent over the air. By default, the Bluetooth stack responds with no key when a key is requested (it is up to the user to respond to the key request event). Authentication of Bluetooth devices is based upon a challenge-response transaction. Bluetooth allows for a PIN or passkey used to create other 128-bit keys used for security and encryption. The encryption key is derived from the link key used to authenticate the pairing devices. Also, the limited range and fast frequency hopping of the Bluetooth radios make long-distance eavesdropping difficult.

Recommendations are:

- Perform pairing in a secure environment.
- Keep PIN codes private and do not store the PIN codes in the device.
- Implement application-level security.

Bluetooth Profiles

The device supports the Bluetooth services listed.

Table 16 Bluetooth Profiles

| Profile | Description |
|--------------------------------------|---|
| Service Discovery Protocol (SDP) | Handles the search for known and specific services as well as general services. |
| Serial Port Profile (SPP) | Allows use of RFCOMM protocol to emulate serial cable connection between two Bluetooth peer devices. For example, connecting the device to a printer. |
| Object Push Profile (OPP) | Allows the device to push and pull objects to and from a push server. |
| Human Interface Device Profile (HID) | Allows Bluetooth keyboards, pointing devices, gaming devices and remote monitoring devices to connect to the device. |
| Out of Band (OOB) | Allows exchange of information used in the pairing process. Pairing is completed using the Bluetooth radio, but requires information from the OOB mechanism. Using OOB with NFC enables pairing when devices simply get close, rather than requiring a lengthy discovery process. |
| Generic Attribute Profile (GATT) | Provides profile discovery and description services for Bluetooth Low Energy protocol. It defines how attributes are grouped together into sets to form services. |
| Generic Access Profile (GAP) | Use for device discovery and authentication. |
| Object EXchange (OBEX) | Facilitates the exchange of binary objects between devices. |

Bluetooth Power States

The Bluetooth radio is off by default.

- **Suspend** - When the device goes into Sleep mode, the Bluetooth radio stays on.
- **Airplane Mode** - When the device is placed in Airplane Mode, the Bluetooth radio is not turned off when the device is connected to a Bluetooth headset or hearing device.

Bluetooth Radio Power

Turn off the Bluetooth radio to save power or if entering an area with radio restrictions (for example, an airplane). When the radio is off, other Bluetooth devices cannot see or connect to the device. Turn on the Bluetooth radio to exchange information with other Bluetooth devices (within range). Communicate only with Bluetooth radios in close proximity.



NOTE: To achieve optimal battery life, turn off radios when not in use.

Enabling Bluetooth

1. Swipe down from the Status bar to open the Notification panel.
2. Touch  to turn Bluetooth on.

Disabling Bluetooth

1. Swipe down from the Status bar to open the Notification panel.
2. Touch  to turn Bluetooth off.

Discovering Bluetooth Device(s)

The device can receive information from discovered devices without pairing. However, once paired, the device and a paired device exchange information automatically when the Bluetooth radio is on.

1. Ensure that Bluetooth is enabled on both devices.
2. Ensure that the Bluetooth device to discover is in discoverable mode.
3. Ensure that the two devices are within 10 m (32.8 ft) of one another.
4. Swipe down from the Status bar to open the Quick Access panel.
5. Touch and hold **Bluetooth**.
6. Touch **Pair new device**. The device begins searching for discoverable Bluetooth devices in the area and displays them under **Available devices**.
7. Scroll through the list and select a device. The Bluetooth pairing request dialog box appears.
8. Touch **Pair** on both devices.
9. The Bluetooth device is added to the **Paired devices** list and a trusted (“paired”) connection is established.

Changing the Bluetooth Name

By default, the device has a generic Bluetooth name that is visible to other devices when connected.

1. Go to **Settings**.
2. Touch **Connected devices** > **Connection preferences** > **Bluetooth**.
3. If Bluetooth is not on, move the switch to turn Bluetooth on.
4. Touch **Device name**.
5. Enter a name and touch **RENAME**.

Connecting to a Bluetooth Device

Once paired, connect to a Bluetooth device.

1. Go to **Settings**.
2. Touch **Connected devices** > **Connection preferences** > **Bluetooth**.
3. In the list, touch the unconnected Bluetooth device.

When connected, **Connected** appears below the device name.

Selecting Profiles on the Bluetooth Device

Some Bluetooth devices have multiple profiles.

1. Go to **Settings**.
2. Touch **Connected devices** > **Connection preferences** > **Bluetooth**.
3. In the **Paired Devices** list, touch  next to the device name.
4. Turn on or off a profile to allow the device to use that profile.

Unpairing a Bluetooth Device

Unpairing a Bluetooth device erases all pairing information.

1. Go to **Settings**.
2. Touch **Connected devices** > **Connection preferences** > **Bluetooth**.
3. In the **Paired Devices** list, touch  next to the device name.
4. Touch **FORGET**.

Cast

Use **Cast** to mirror the device screen on a Miracast enabled wireless display.

1. Go to **Settings**.
2. Touch **Connected devices** > **Connection preferences** > **Cast**.
3. Touch  > **Enable wireless display**.

The device searches for nearby Miracast devices and lists them.

4. Touch a device to begin casting.

Near Field Communication

NFC/HF RFID is a short-range wireless connectivity technology standard that enables a secure transaction between a reader and a contactless smartcard.

The technology is based on ISO/IEC 14443 type A and B, FeliCa (proximity) ISO/IEC 15693 (vicinity) standards, using the HF 13.56 MHz unlicensed band.

The device supports the following operating modes:

- Reader mode
- Card Emulation mode.

The device also supports ECP polling.

Using NFC, the device can:

- Read contactless cards, such as contactless tickets, ID cards, and ePassport.
- Read and write information to contactless cards, such as SmartPosters and tickets, as well as devices with an NFC interface, such as vending machines.
- Read information from supported medical sensors.
- Pair with supported Bluetooth devices such as printers, ring scanners (for example, RS6000), and headsets (for example, HS3100).
- Emulate a contactless card such as a ticket.

The device's NFC antenna is positioned to read NFC cards from the top of the device while the device is being held.

Reading NFC Cards

Read contactless cards using NFC.

1. Launch an NFC-enabled application.
2. Hold the device as shown.

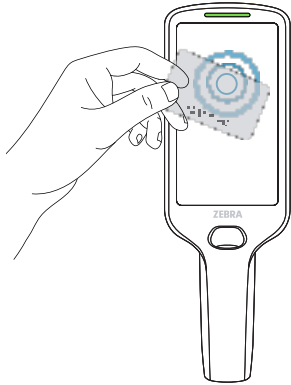

3. Move the card to the NFC antenna on the front of the device.
4. Hold the card steadily until the transaction is complete (usually indicated by the application).

Enterprise NFC Settings

Improve NFC performance or increase battery life by selecting which NFC features to use on the device.

- **Card Detection Mode** - Select a card detection mode.
 - **Low** - Increases battery life by lowering the NFC detection speed.
 - **Hybrid** - Provides a balance between NFC detection speed and battery life (default).
 - **Standard** - Provides the best NFC detection speed, but reduces battery life (Mandatory setting for ECP Polling).

- **Supported Card Technology** - Select an option to detect only one NFC tag type, increasing battery life, but reducing detection speed.
 - **ISO 14443 Type A**
 - **ISO 14443 Type B**
 - **FeliCa**
 - **ISO15693**
- **NFC Debug Logging** - Use to enable or disable debug logging for NFC.
- **Other NFC settings available with Zebra administrator tools (CSP):**
 - **Communication speed for Type A and Type B cards and ISO 14443-4 cards** - Higher rate improves transaction speed.
 - **NDEF Support** - Improves card detection speed for non-NDEF cards.
 - **CPU Speed** - Boosts CPU speed during short NFC transactions and improves transaction speed.
 - **Card Emulation** - Enables workaround for Card Emulation interoperability issues.
 - **Reset to Factory Defaults** - Default settings are reset to factory defaults.

Accessories

This section provides information for using the accessories for the device.

A typical Personal Shopper system is comprised of a family of hardware devices interconnected through a WLAN radio backbone to the retail establishment's server(s). The hardware devices are the device personal shoppers, single-slot or three-slot cradles, power supplies, and cables. A dispenser typically refers to a piece of furniture that has mounted to it the cradles, their power supplies, and cables.

Customers (retail establishments) design their own dispensers to meet their particular floor space and display requirements. The information in this section should help a customer to design a dispenser and to understand the installation requirements.



IMPORTANT: MC18 cradles are compatible with this device.

Device Accessories

This table lists the accessories available for the device.

Table 17 Accessories

| Accessory | Part Number | Description |
|---|--------------------|--|
| Cradles | | |
| High Density (HD) 3-Slot Cradle (Locking). | CRD-MC18-3SLCKH-01 | The cradle is used for docking up to three devices in HD installation configuration. The cradle slots are equipped with a mechanism that locks the devices inside the slots. The devices are placed with the display facing to the front. Requires power supply unit (PWR-BGA12V108W0WW), DC line cord, and country-specific AC line cord (sold separately). |
| High Density (HD) 3-Slot Cradle (Non-Locking) | CRD-MC18-3SLOTH-01 | The cradle is used for docking up to three devices in HD installation configuration. The devices are placed with the display facing to the front. Requires power supply unit (PWR-BGA12V108W0WW), DC line cord, and country-specific AC line cord (sold separately). |

Table 17 Accessories (Continued)

| Accessory | Part Number | Description |
|-----------------------|--------------------|---|
| 1-Slot Cradle | CRD-MC18-1SLOT-01 | The cradle is used for docking a single device. The devices are placed with the display facing to the front. Requires power supply unit (PWR-BGA12V108W0WW), DC line cord, and country-specific AC line cord (sold separately). |
| Chargers | | |
| Power Supply Unit | PWR-BGA12V108W0WW | 100–240VAC, 12VDC, 9A. Requires country-specific AC line cord and DC cable (sold separately). |
| AC Line Cord | 23844-00-00R | AC Line Cord, 7.5-ft, grounded, three-wire cord for power supplies. Associated Country: United States |
| AC Line Cord | 50-16000-221R | AC Line Cord, 1.8-meter, grounded, three-wire cord; USA NEMA 5-15P. Associated Country: United States |
| AC Line Cord | 50-16000-671R | AC Line Cord, 1.8-meter, grounded, three-wire cord; CIE 23-16 plug. Associated Country: Italy. |
| AC Line Cord | 50-16000-217R | AC Line Cord, 1.9-meter, grounded, three-wire cord; AS 3112 plug. Associated Countries: Australia, New Guinea |
| AC Line Cord | 50-16000-218R | AC Line Cord, 1.8-meter, grounded, three-wire cord; NEMA 1-15P plug. Associated Country: Japan. |
| AC Line Cord | 50-16000-219R | AC Line Cord, 1.8-meter, grounded, three-wire cord; BS1363 plug. Associated countries: Hong Kong, Iraq, Malaysia, Singapore, United Kingdom. |
| AC Line Cord | 50-16000-220R | AC Line Cord, 1.8-meter, grounded, three-wire cord; CEE 7/7 plug. Associated countries: Europe, Abu Dhabi, Bolivia, Dubai, Egypt, Iran, Russia, Vietnam. |
| AC Line Cord | 50-16000-257R | AC Line Cord, 1.8-meter, grounded, three-wire cord; IEC 60320 C13 plug. Associated Country: China. |
| AC Line Cord | 50-16000-669R | 1.9-meter, grounded, three-wire cord; BS 546 Plug. Associated country: India. |
| AC Line Cord | 50-16000-672R | 1.9-meter, grounded, three-wire cord; S132 Plug. Associated country: Israel. |
| AC Line Cord | 50-16000-678R | 36-inch, grounded, three-wire cord. Associated country: United States |
| Cables | | |
| USB Programming Cable | CBL-PS30-USBCHG-01 | USB communication cable for connecting the device to a host computer. |

Table 17 Accessories (Continued)

| Accessory | Part Number | Description |
|--|--------------------|---|
| Interconnection Cable Long | 25-66430-01R | PS20/PS30 cradle interconnection cable (1.5 m/60 in.). Connects cradles to each other to run off one power supply unit (PWR-BGA12V108W0WW). |
| Interconnection Cable Short | 25-66431-01R | PS20/PS30 cradle interconnection cable (32 cm/12.6 in.). Connects cradles to each other to run off one power supply unit (PWR-BGA12V108W0WW). |
| Cradle Interconnection Extension Cable | CBL-MC18-EXINT1-01 | PS20/PS30 cradle interconnection extension cable (32 cm/12.6 in.). Connects two interconnection cables (25-66431-01R, sold separately) together to provide the additional length that might be required in some installation designs. |
| DC Charging Cable | CBL-DC-394A1-02 | DC charging cable (0.5 m/19.5 in.) used to connect a power supply unit (PWR-BGA12V108W0WW) to one 1-slot cradle. |
| DC “Y” Charging Cable Long | CBL-DC-392A1-02 | DC “Y” charging cable (2 m/79.4 in.). Connects a power supply unit (PWR-BGA12V108W0WW) to two separate 3-slot cradles. |
| DC “Y” Charging Cable Short | CBL-DC-393A1-02 | DC “Y” charging cable (1 m/39.7 in.). Connects a power supply unit (PWR-BGA12V108W0WW) to two separate 3-slot cradles. |
| Miscellaneous | | |
| Lithium Ion Battery | BTRY-PS30-35MA-01 | PS30 PowerPrecision+ Lithium Ion Battery. |
| | BTRY-PS30-35MA-10 | PS30 PowerPrecision+ Lithium Ion Battery (QTY-10). |
| Release Key | KT-MC18-CKEY-20 | Tool used to mechanically unlock the device from the 3-Slot Cradle and the 1-Slot Cradle (QTY-20). |
| Terminal Reboot Tool | KT-MC18-REBOOT-05 | Tool used to perform a cold boot of the device (QTY-5). |
| Cradle Cover Removal Tool | KT-MC18-CTOOL-01 | Tool used for removing the 3-slot cradle cover. |
| Deployment Kit | KT-MC18-CSTKIT-01 | PS20/PS30 Deployment Starter Kit. Includes: 20-pack of Release Key (KT-MC18-CKEY-20) 5-pack of Terminal Reboot Tool KT-MC18-REBOOT-05) One Three Slot Cradle Cover Removal Tool (KT-MC18-CTOOL-01) |
| Cart Holder Mounting Kit | PSS-3SH01-00R | Kit for mounting the device on a shopping cart. |

Table 17 Accessories (Continued)

| Accessory | Part Number | Description |
|---------------------------------|-------------------|--|
| Soft Holster | SG-PS20-SFTHLT-01 | Allows for wearing the device on the hip (includes belt clip) or crossbody, with an additional shoulder strap. |
| Tempered Glass Screen Protector | MISC-PS30-SCRN-05 | Provides additional protection for device display (5-pack). |

Accessories for Charging

Use one of the following accessories to charge the PS30 personal shopper.



NOTE: Ensure that you follow the guidelines for battery safety described in [Battery Safety Guidelines](#).

Table 18 Charging Cradles

| Description | Part Number | DC Cable | Interconnect Cable | Extension Cable |
|---|--------------------|---|------------------------------|--------------------|
| 1-Slot Cradle | CRD-MC18-1SLOT-01 | CBL-DC-394A1-02 CBL-DC-393A1-02 CBL-DC-392A1-02 | 25-66431-01R 25-66430-01R | — |
| High Density (HD) 3-Slot Cradle (Locking) | CRD-MC18-3SLCKH-01 | CBL-DC-394A1-02 CBL-DC-393A1-02 CBL-DC-392A1-02 | 25-66431-01R 25-66430-01R | CBL-MC18-EXINT1-01 |
| High Density (HD) 3-Slot Cradle (Non-Locking) | CRD-MC18-3SLOTH-01 | CBL-DC-394A1-02 CBL-DC-393A1-02 CBL-DC-392A1-02 | 25-66431-01R 25-66430-01R | CBL-MC18-EXINT1-01 |

1-Slot Cradle

The 1-slot cradle charges one device at a time. The device locks into place and faces out while charging.

Figure 17 1-Slot Cradle

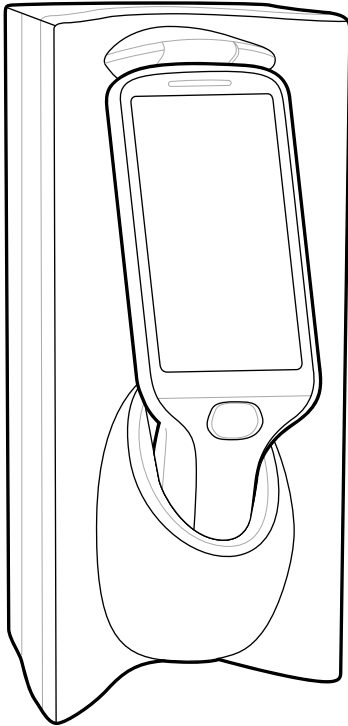

See Also

[Releasing the Device from Locking Charging Cradles](#)

Setup

This section guides you through the process of connecting the 1-slot cradles and mounting them on a wall.

The process for setting up the cradles includes the following:

1. Select the charging mode.
2. Mount the 1-slot cradles on a dispenser wall.
3. Connect the wires to the cables.
4. Assemble the cradle housing.

System Cabling Limitations

There are some general limitations that must be taken into account when designing a dispenser and ordering hardware elements of a Personal Shopper system.

- No more than six cradles can be powered off each leg of the “Y” power cable.
- A power supply cable runs from the power supply to one or two cradles.
- Cradle interconnection cables run between each successive cradle in the chain.

- The power supply is air-cooled, and as such needs some circulation of fresh air around it. Do not enclose it in a small airtight location.
- Power supplies must be mounted in their natural, landscape orientation. They contain fans and their vents must allow for the free flow of air.
- Power supplies should be mounted either above or below dispensers and entrance heads. Mounting of power supplies to the right or left is not preferred.
- When laying out your furniture and cabling plan, routing should be as direct as possible. Routing should follow vertical and horizontal runs through the modules. A set of labels, numbered 1 to 12, is part of each power supply unit. These labels are to be used to track the number of loads on a particular supply. Each label is designed to be attached to the cradle interconnection cable when a cradle is added to the daisy chain. When all labels are used, the supply is fully loaded.

The following image shows how the maximum number of cradles can be cabled to a power supply using power cable CBL-DC-394A1-02.

Figure 18 Maximum Number of Charge Cradles per Power Supply

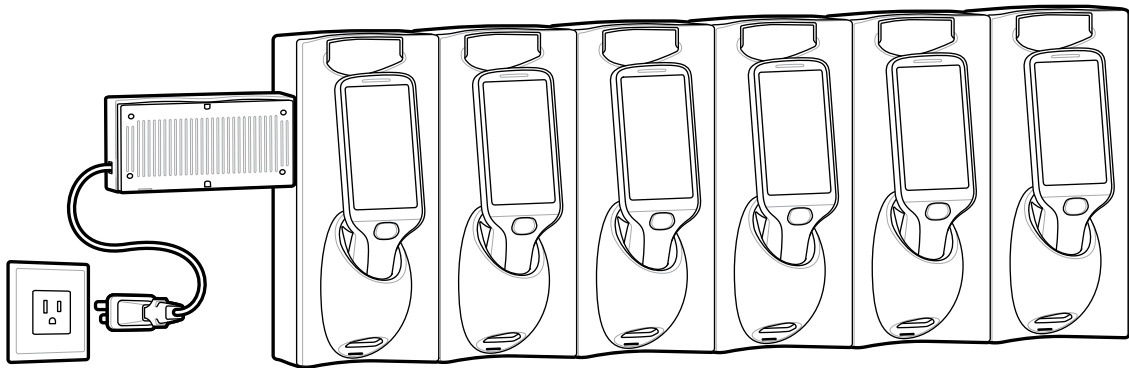

The following images show how the maximum number of cradles can be cabled to a power supply using the “Y” power cable CBL-DC-392A1-02. Note that there are only six cradles per leg of the power supply cable and only 12 cradles in total in Standard Charge Mode. Fast Charge Mode is limited to 9 cradles in total.

Figure 19 Maximum Number of Charge Cradles per Power Supply with “Y” Power Cable, Standard Charge Mode

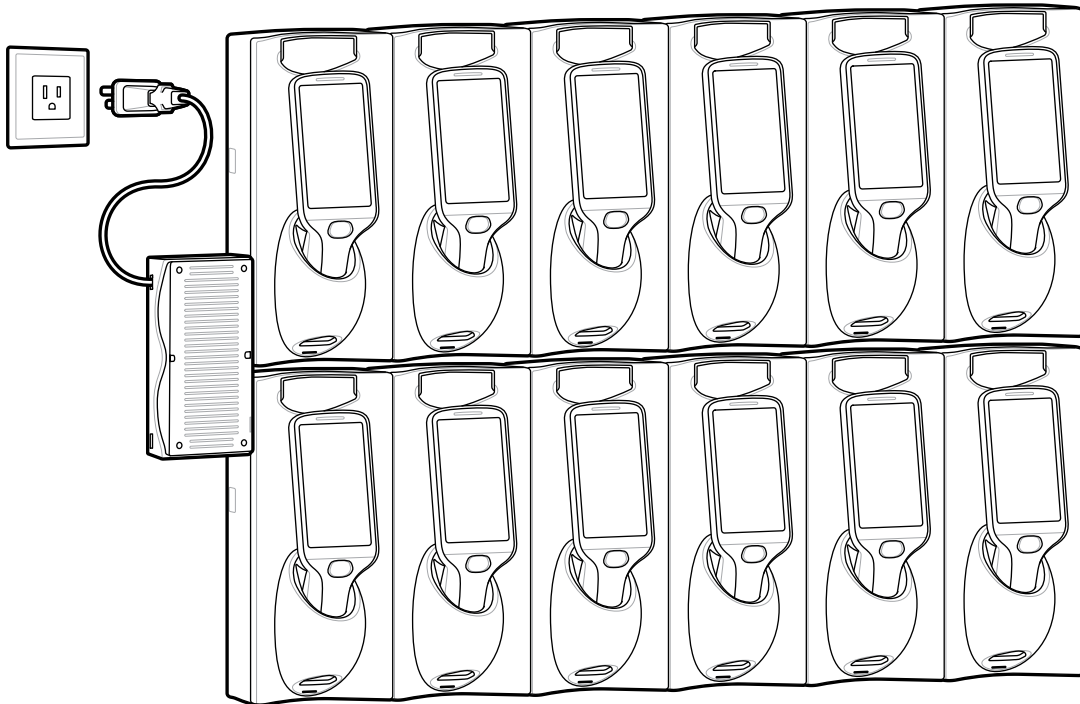
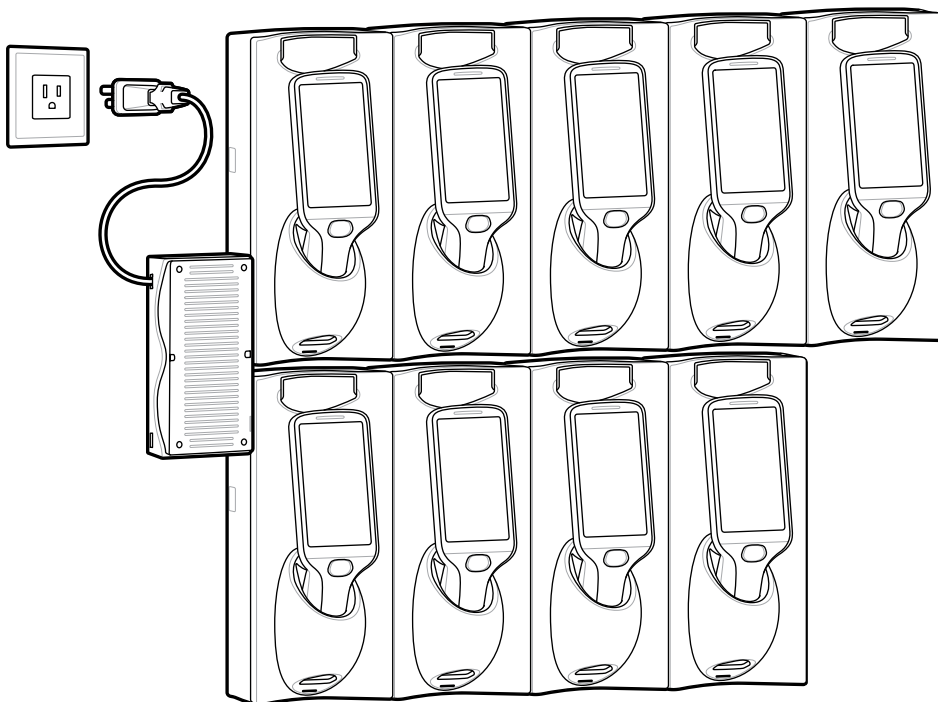

Figure 20 Maximum Number of Charge Cradles per Power Supply with “Y” Power Cable, Fast Charge Mode



Charging Modes

The 1-slot cradles can be installed in the following charging modes:

- Standard charging
- Fast charging

There are some general charging considerations that must be taken into account when designing a dispenser and ordering hardware elements of a system:

Standard Charging Mode

- No more than 12 cradles can be powered off of one power supply unit (p/n PWR-BGA12V108W0WW) using “Y” power cable CBL-DC-392A1-02.
- The current draw by each docked device can reach a maximum of 1A.

Fast Charging Mode

- No more than six cradles can be powered off of one power supply unit (p/n PWR-BGA12V108W0WW) using power cable CBL-DC-394A1-02. Using “Y” power cable CBL-DC-392A1-02, no more than nine cradles.
- The current draw by each docked device can reach a maximum of 1.5A.

Mounting the Single Slot Cradle on a Dispenser Wall

The cradle contains two mounting holes in the back housing so that it can be hanged on screws fixed to supporting furniture. In addition, it comes with plugs and a variety of cable routing outlets.

1. Loosen two captive screws securing the front cover to the base.

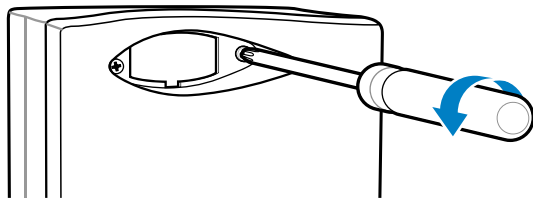

2. Pull the front cover away from the base and then lift it out of the base.

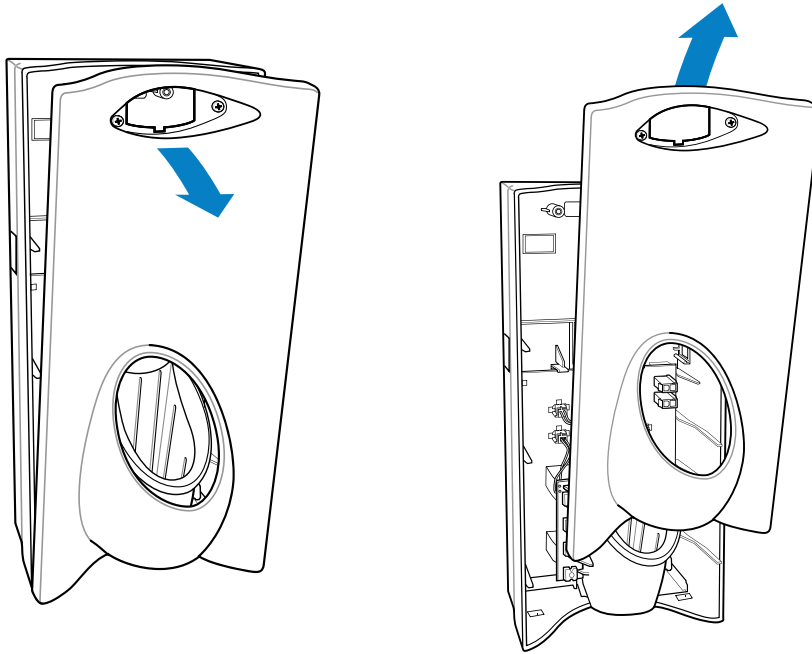

3. Use two screws to hang the cradle on a wall.

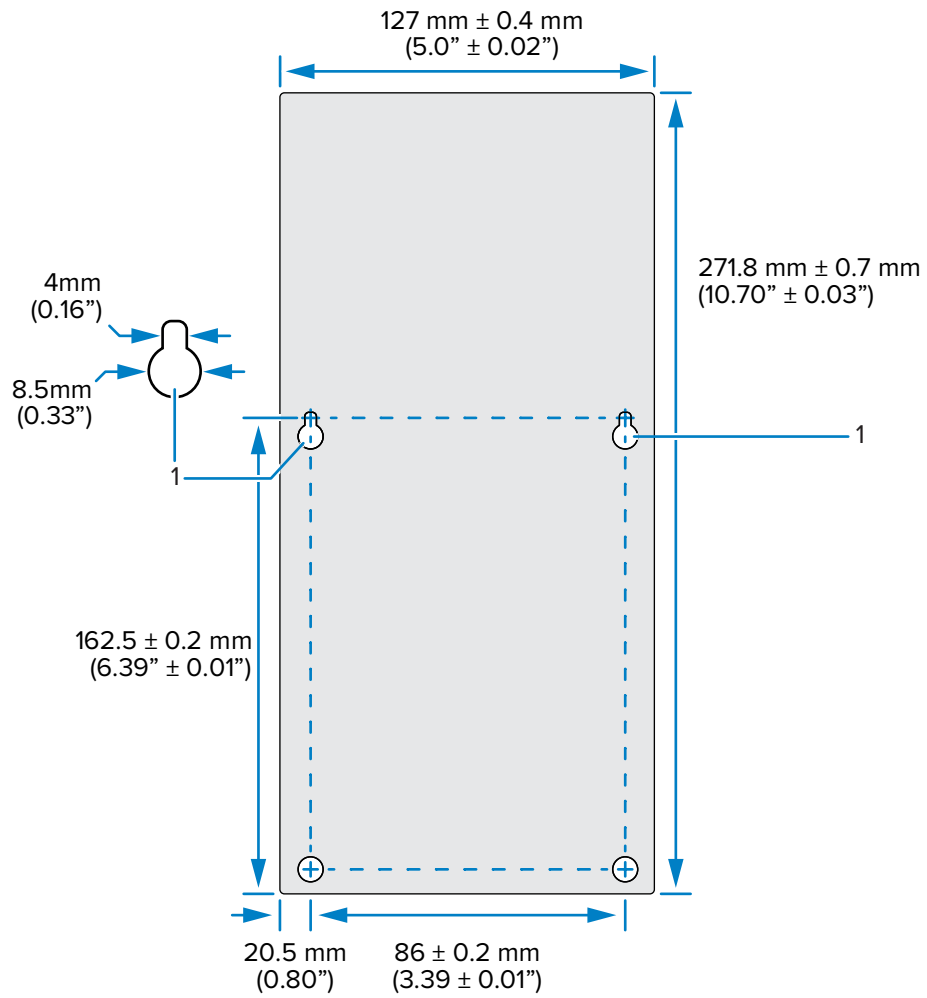
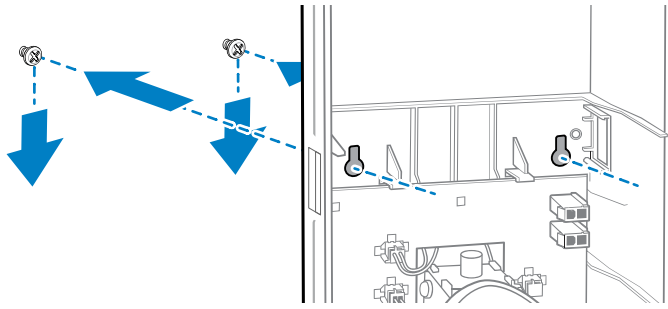

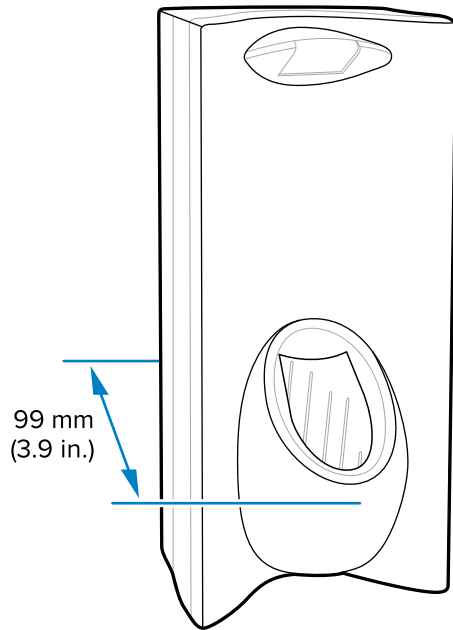

Wiring



NOTE: During installation, ensure all interconnect cables are fully enclosed within the power supply or cradle enclosure.

1. Install power supply, including AC line cord and power cable, into Decorative Housing.

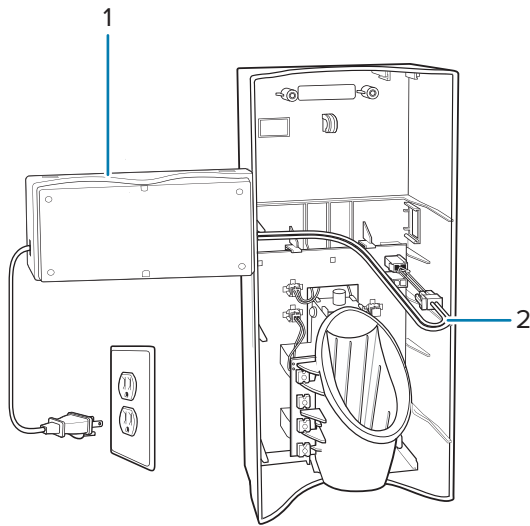

| | |
|---|--|
| 1 | Power Supply PWR-BGA12V108W0WW (inside Decorative Housing) |
| 2 | Power Cable CBL-DC-394A1-02 |

2. Insert power cable through a cable outlet of cradle back housing.
3. Plug the connector into the power connector on the printed circuit board.

4. If more than one cradle is being installed, connect the interconnect cable from the first cradle to the second cradle.

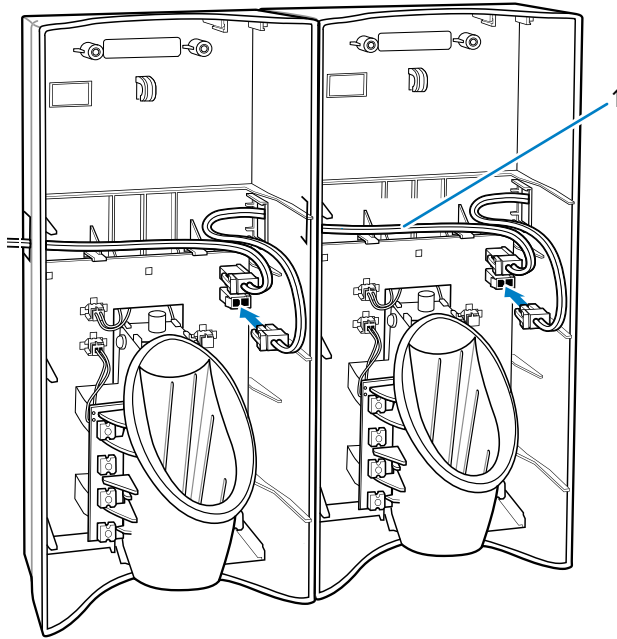

| | |
|---|---------------------------------|
| 1 | Interconnect Cable 25-66431-01R |
|---|---------------------------------|

5. Use plugs to cover unused cable outlets.

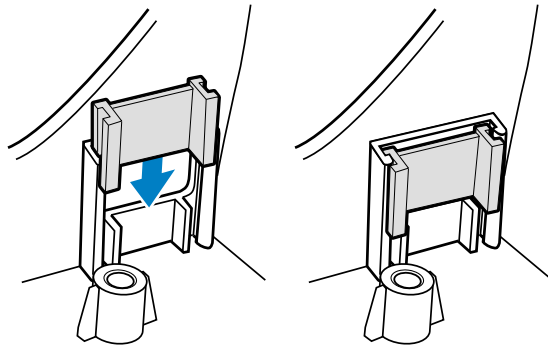

Assembly

1. Replace the cover.

- Secure the cover with screws.

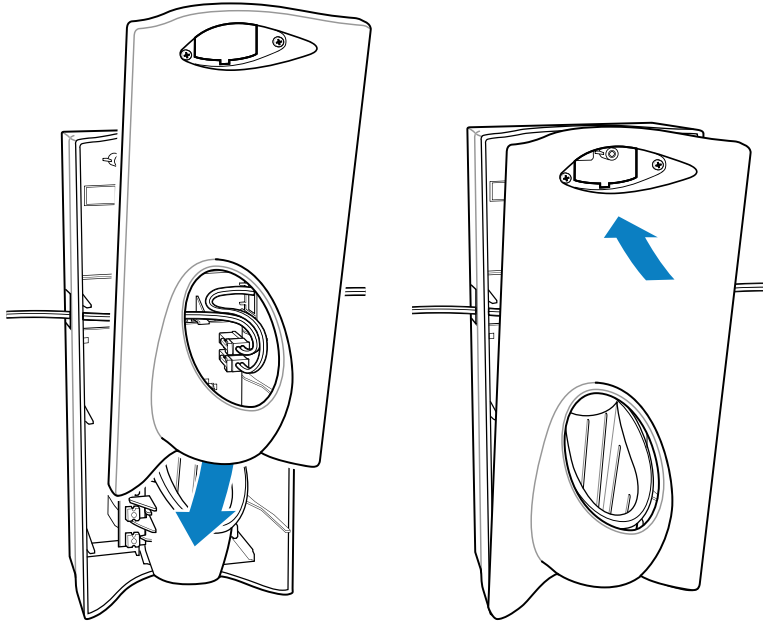

IMPORTANT: Do not install the target cover until you are sure that you do not need to remove the front cover again.

- Insert the barcode target cover.
- Push the target cover into the front cover until it snaps into place.

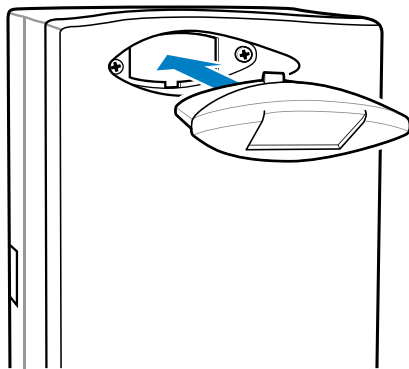

Charging the Device

To achieve optimal charging results, use only Zebra charging accessories and batteries. Charge batteries at room temperature with the device in sleep mode.

The device or accessory always performs battery charging in a safe and intelligent manner. The device or accessory indicates when charging is disabled due to abnormal temperatures via its LED, and a notification appears on the device display.

The battery charges from 0 to 90% depending on the following conditions, measured at room temperature:

- In normal charge mode, the charge time is less than 4 hours.

- In fast charge mode, the charge time is less than 3 hours.

| Temperature | Battery Charging Behavior |
|----------------------|--|
| 0–40°C (32 to 104°F) | Optimal charging range. |
| Above 37°C (98°F) | The device or cradle may, for small periods of time, alternately enable and disable battery charging to keep the battery at acceptable temperatures. |

1. Connect the charging accessory to the appropriate power source.
2. Insert the device into a cradle.

Figure 21 1-Slot Cradle

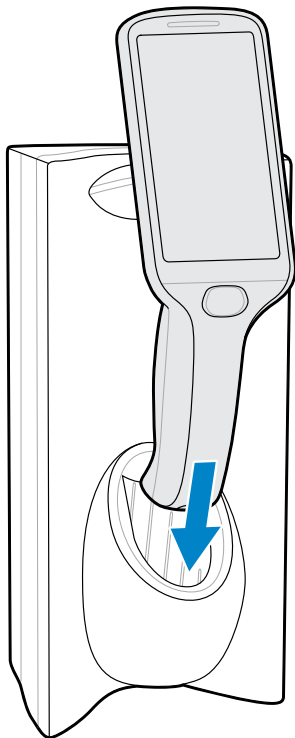

The device turns on and begins charging, and the LED status bar blinks green.

3-Slot Cradle

The 3-slot cradle, which can charge up to three devices at a time, can be a locking or a non-locking model. The devices face out when the cradle is wall-mounted and face up if it is used on a desktop.

Figure 22 3-Slot Cradle, Wall Mounted

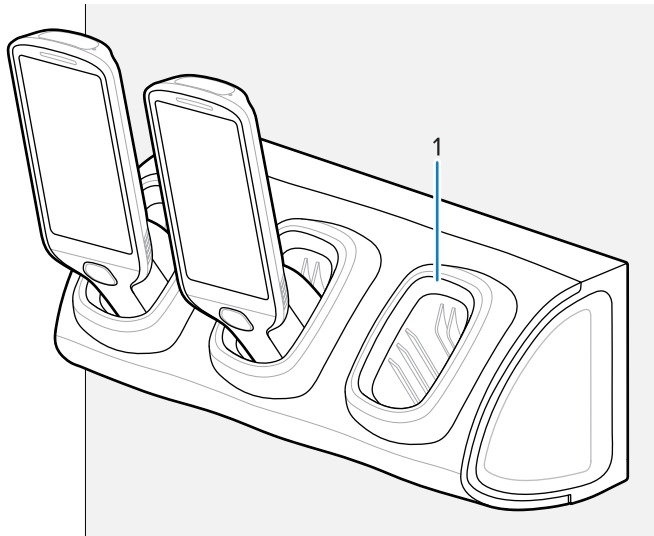
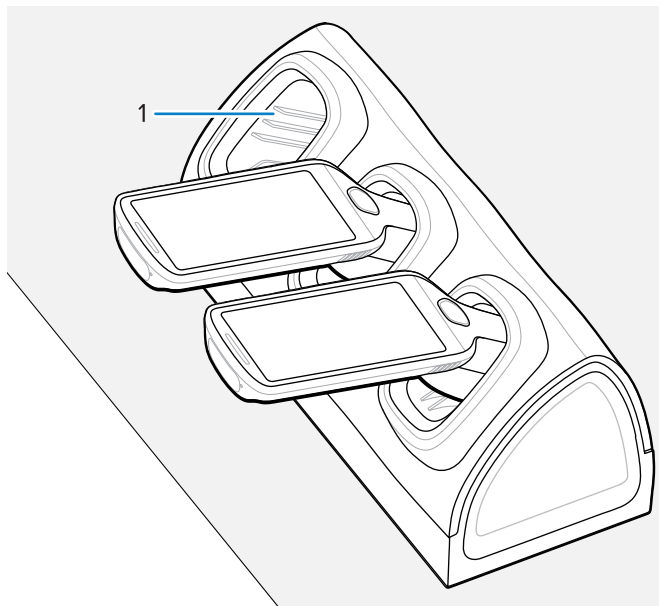

Figure 23 3-Slot Cradle, Desktop Configuration



| | |
|---|---------------|
| 1 | Charging slot |
|---|---------------|

See Also

[Releasing the Device from Locking Charging Cradles](#)

Setup

This section guides you through the process of connecting the 3-slot cradles with the option of mounting them on a wall.

The process for setting up the cradles includes the following:

1. Select the mounting configuration.
2. Select the charging mode.
3. Mount the 3-slot cradles on a dispenser wall.

Mounting Configurations

Three slot cradles can be installed in the following mounting configurations:

- High Density (HD) configuration - Using HD cradles
- Desktop configuration - Using stand-alone cradle(s) on a flat surface

High-Density Configuration

The cradle can be installed in a high-density configuration so that the displays on the devices are facing the user. In this configuration, cradles are installed with a vertical gap of 35 mm between each other.



NOTE: In the high-density configuration, the devices have a 10-degree forward-facing tilt that should be taken into consideration, especially if furniture is planned to be placed in front of the dispenser wall.

Figure 24 Installation in High-Density Configuration

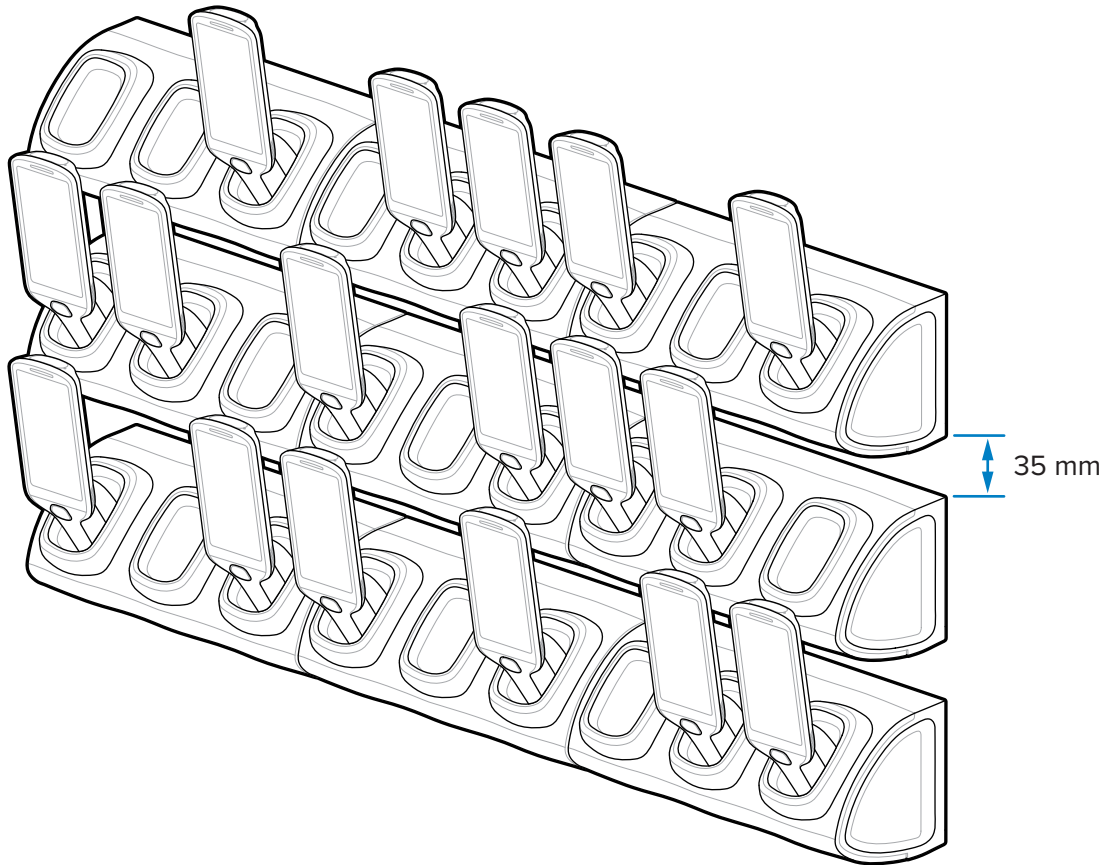

The installation of the dispenser wall can be designed so that it tilts slightly backward at the following angles:

Figure 25 Dispenser Wall Angles

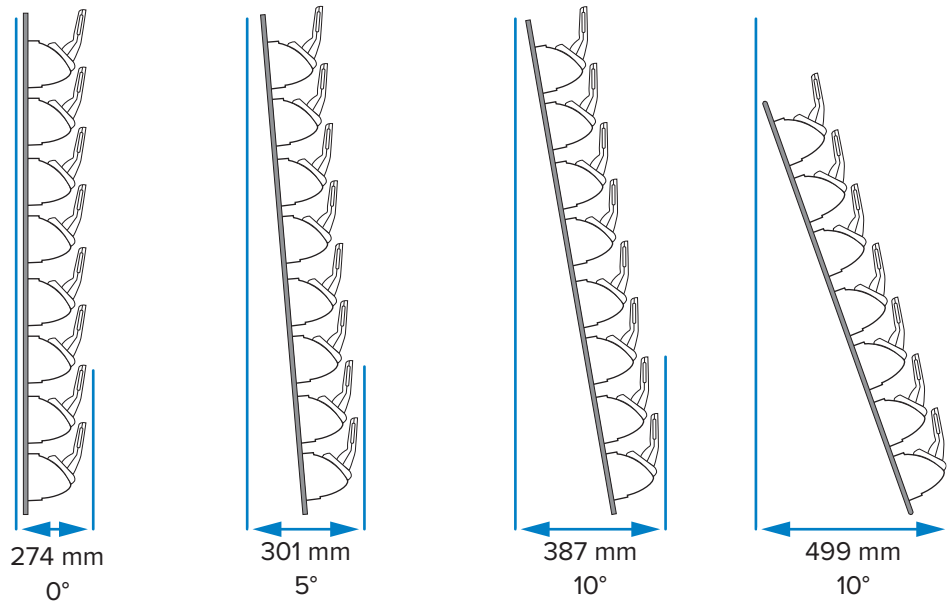

Desktop Configuration

In the desktop configuration, the cradle can be placed on a flat tabletop or shelf at the checkout area or in backroom locations.

Figure 26 Installation in Desktop Configuration

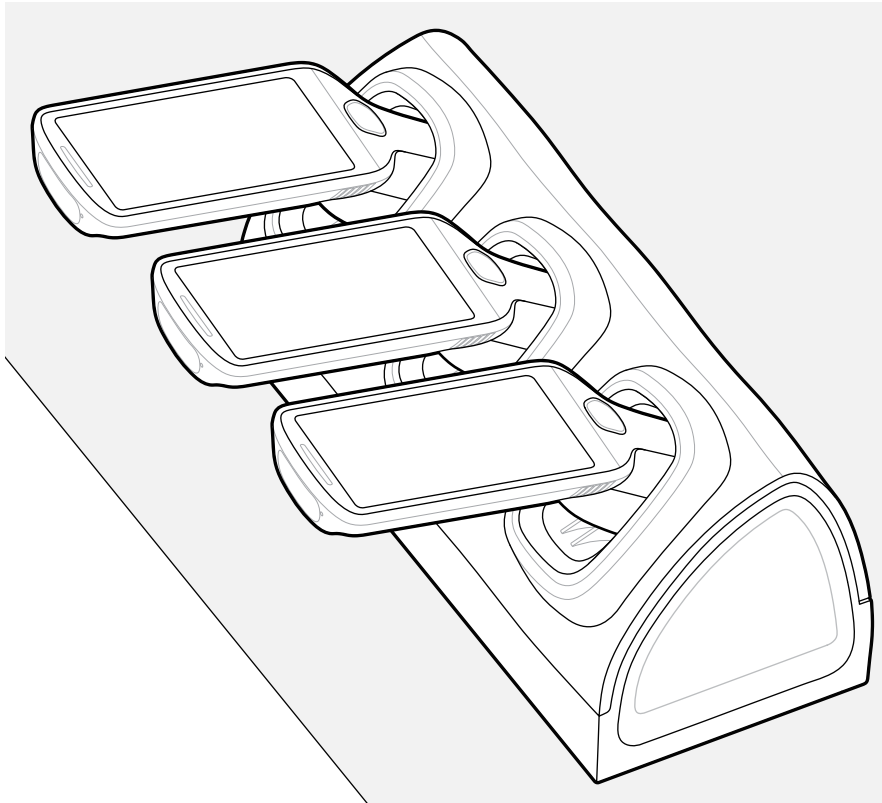

Charging Modes

The 3-Slot Cradles can be installed in the following charging modes:

- Standard charging
- Fast charging

There are some general charging considerations that must be taken into account when designing a dispenser and ordering hardware elements of a system.

Standard Charging Mode

- No more than four cradles can be powered off of one power supply unit (p/n PWR-BGA12V108W0WW) using “Y” power cable (p/n CBL-DC-392A1-02 or p/n CBL-DC-393A1-02), power extension cables (p/n CBL-MC18-EXINT1-01) and interconnect cables (p/n 25-66431-01R).
- The current draw by each docked device can reach a maximum of 1A.
- Cable routing should be as direct as possible. Routing should follow vertical and horizontal runs through the modules.

The following illustration shows how the four cradles can be cabled to a power supply unit in standard charging mode.

Figure 27 Standard Charging Mode - Cable Connections

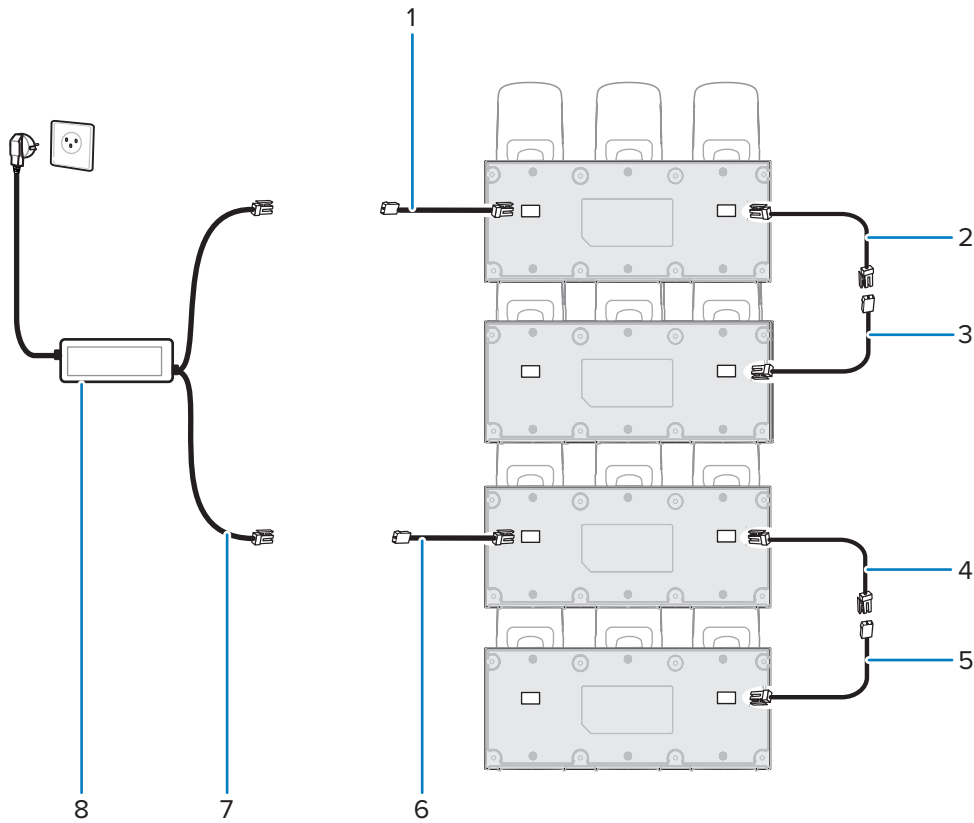

| | |
|---|---|
| 1 | Power Extension Cable (p/n CBL-MC18-EXINT1-01) |
| 2 | Interconnect Cable (p/n 25-66431-01R) |
| 3 | Cradle Interconnection Extension Cable (p/n CBL-MC18-EXINT1-01) |
| 4 | Interconnect Cable (p/n 25-66431-01R) |
| 5 | Cradle Interconnection Extension Cable (p/n CBL-MC18-EXINT1-01) |
| 6 | Power Extension Cable (p/n CBL-MC18-EXINT1-01) |
| 7 | “Y” Power Cable: CBL-DC-392A1-02 or CBL-DC-393A1-02 |
| 8 | Power Supply Unit PWR-BGA12V108W0WW |

Fast Charging Mode

- No more than three cradles can be powered off of one power supply unit (p/n PWR-BGA12V108W0WW) using “Y” power cable (p/n CBL-DC-392A1-02 or p/n CBL-DC-393A1-02), Interconnect cables (p/n 25-66431-01R) and cradle interconnection extension cables (p/n CBL-MC18-EXINT1-01).
- The current draw by each docked device can reach a maximum of 1.5A.
- Cable routing should be as direct as possible. Routing should follow vertical and horizontal runs through the modules.

The following illustration shows how three cradles can be cabled to a power supply unit in fast charging mode.

Figure 28 Fast Charging Mode Cable Connections

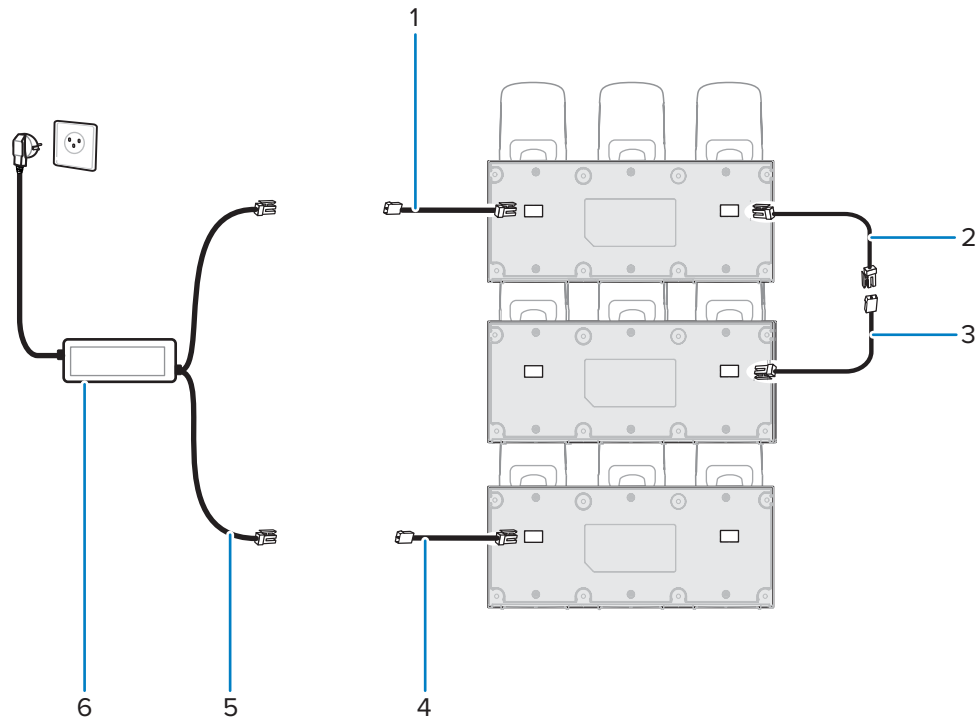

| | |
|---|---|
| 1 | Power Extension Cable (p/n CBL-MC18-EXINT1-01) |
| 2 | Interconnect Cable (p/n 25-66431-01R) |
| 3 | Cradle Interconnection Extension Cable (p/n CBL-MC18-EXINT1-01) |
| 4 | Power Extension Cable (p/n CBL-MC18-EXINT1-01) |
| 5 | “Y” Power Cable: CBL-DC-392A1-02 or CBL-DC-393A1-02 |
| 6 | Power Supply Unit PWR-BGA12V108W0WW |

Mounting the 3-Slot Cradle on a Dispenser Wall

The 3-slot cradle can be bolted to a dispenser wall or to any supporting furniture using eight mounting holes. The back cover of the cradle has two access holes for routing power cables to/from a power supply unit or adjacent cradle.



IMPORTANT: DO NOT connect more than four cradles to a single power supply unit when in standard charging mode or three cradles when in fast charging mode. DO NOT connect the power supply unit to a power outlet until all installation steps are completed.



NOTE: This procedure is an example installation of 3-slot cradles in fast charging mode, high-density configuration.

1. Use the wall mount template to plan and mark the screw locations on the dispenser wall.

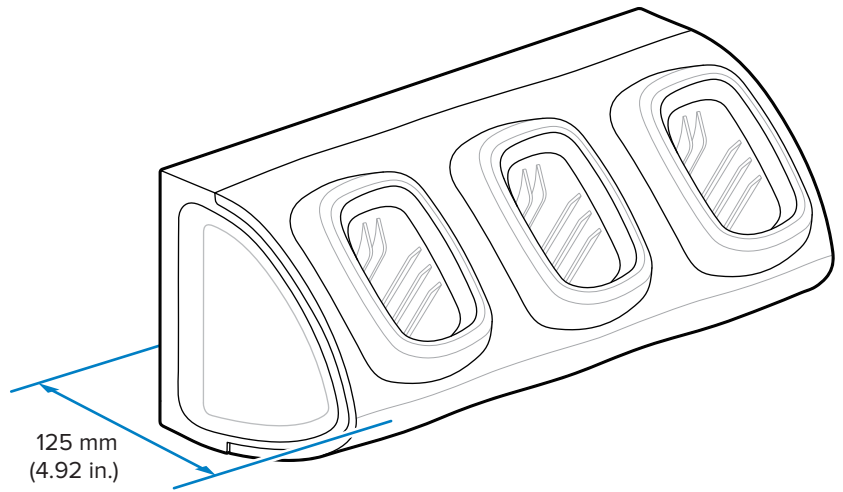
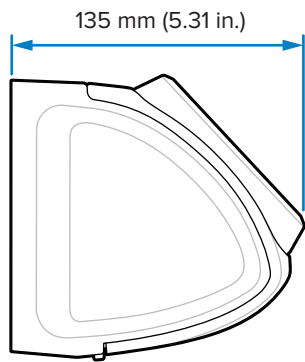
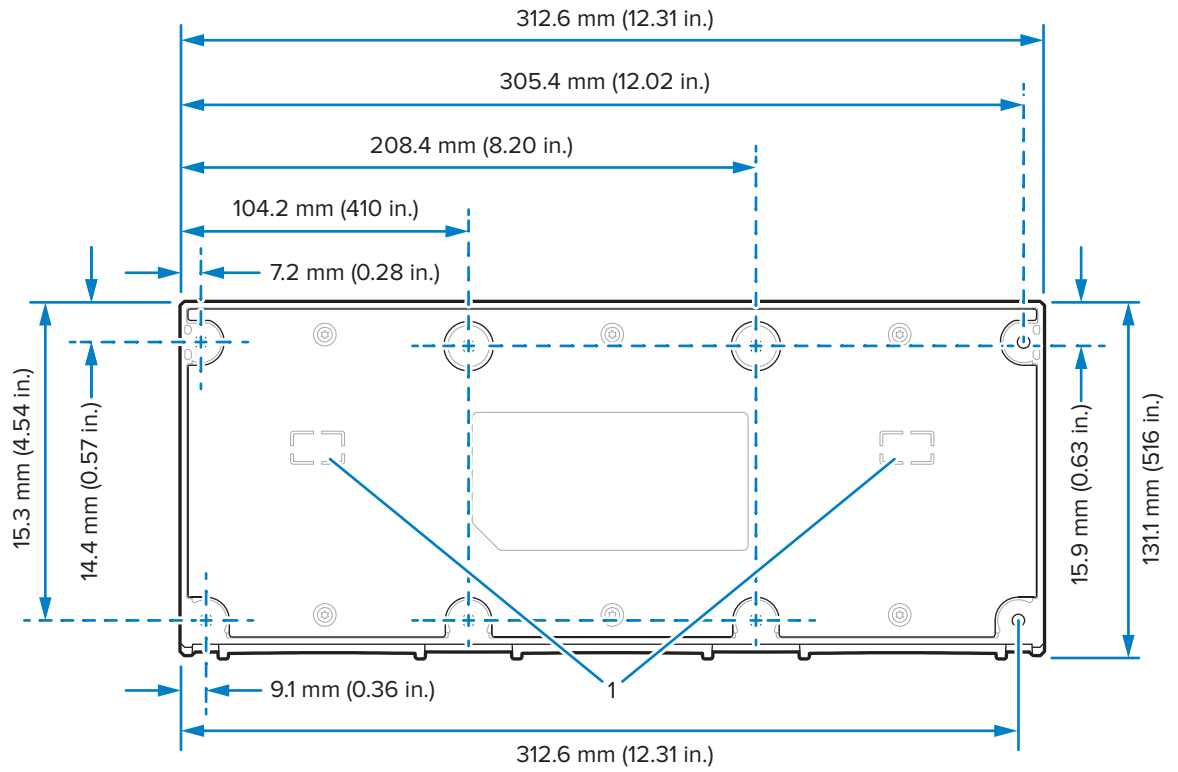

2. In all cradles, plug the power extension cable (p/n CBL-MC18-EXINT1-01) into the free connector on the left slot.

3. Plug the interconnect cable (p/n 25-66431-01R) into the free connector on the right slot.

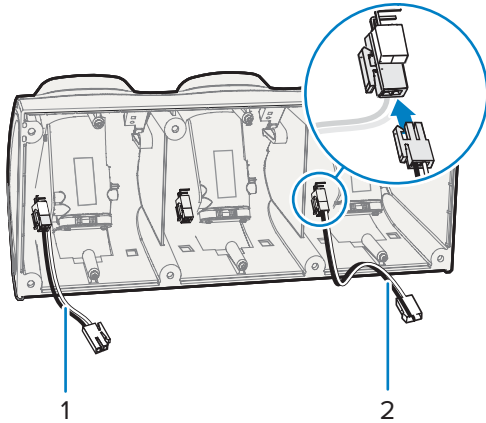

| | |
|---|--|
| 1 | Interconnect Cable (p/n 25-66431-01R) |
| 2 | Cradle Interconnection Extension Cable (p/Interconnect Cable n CBL-MC18-EXINT1-01) |

4. On all of the back covers, knock out the stamped access hole(s).

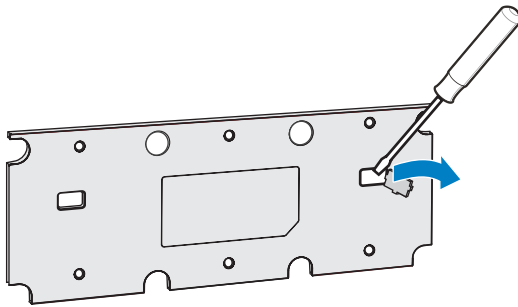

5. Route the interconnect cables through the access holes in the back covers.

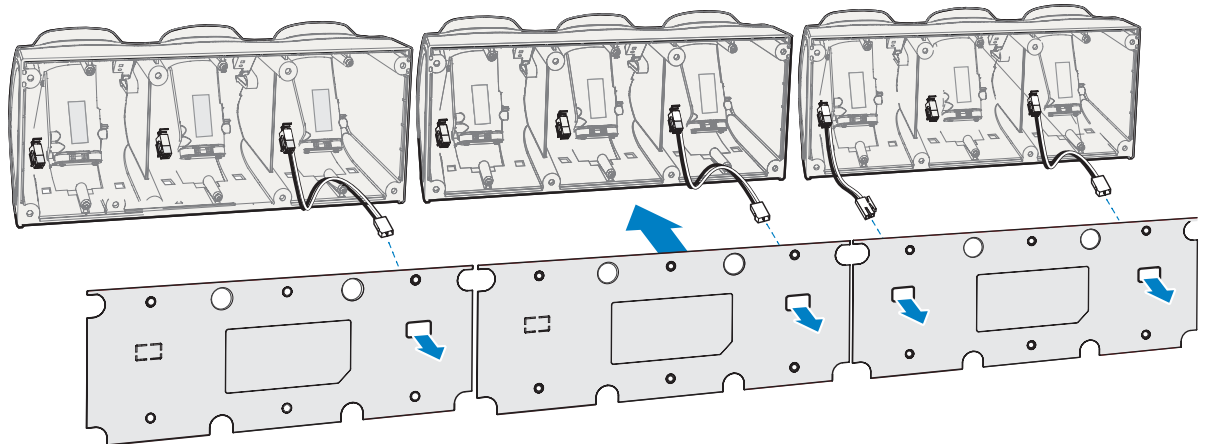

- Secure the back cover of each cradle using six T10 Torx screws (supplied). Torque screws to 6 Kgf-cm (5.2 in-lb).

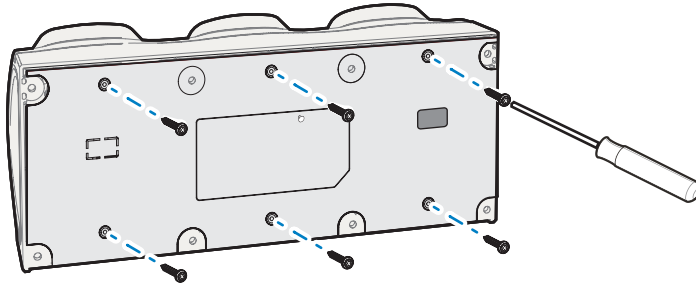

- Insert the front cover removal tool into the two slots on the back of a cradle. Lever upwards and pull to remove the front cover from the cradle.

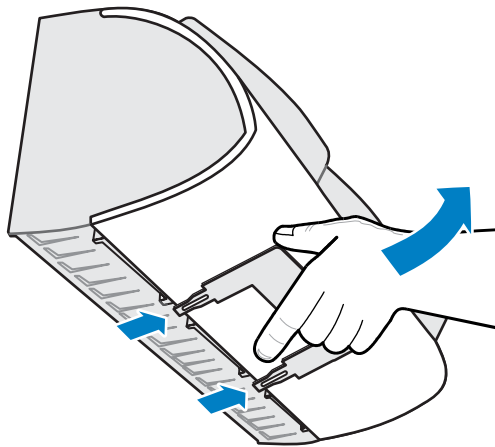

- Position the cradle on the dispenser wall and route all interconnect cables through the access holes in the dispenser wall.

9. Fasten the cradle to the wall using eight screws (not supplied). Make sure to use additional wall mounting hardware, as needed, for safe mounting, according to the wall type.

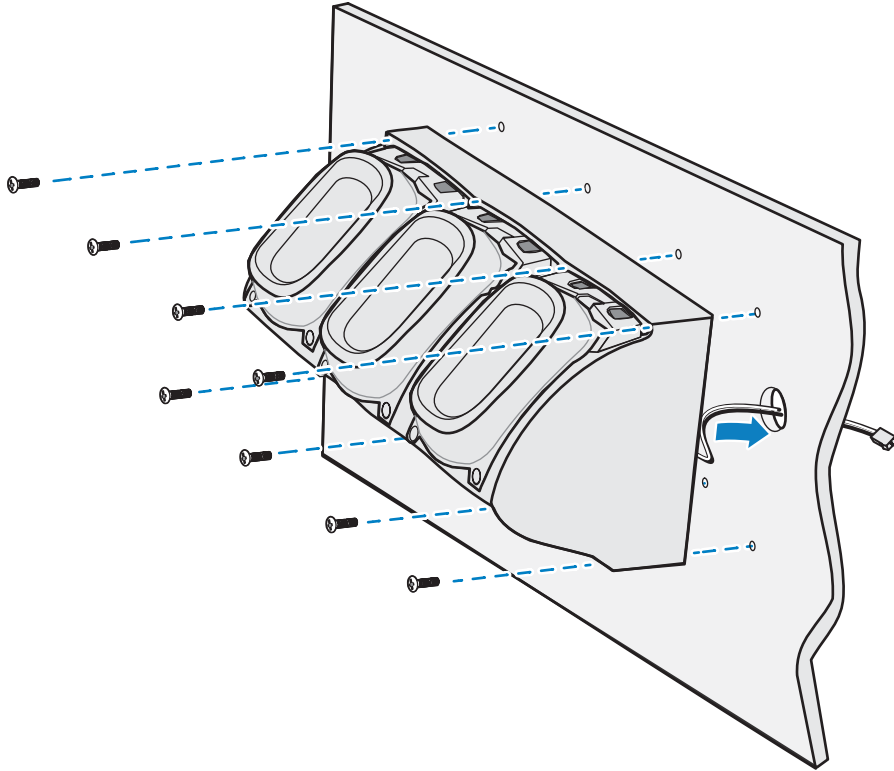

10. Insert the tabs on the upper side of the front cover into the slots on the cradle. Then rotate the cover down until it snaps into place.

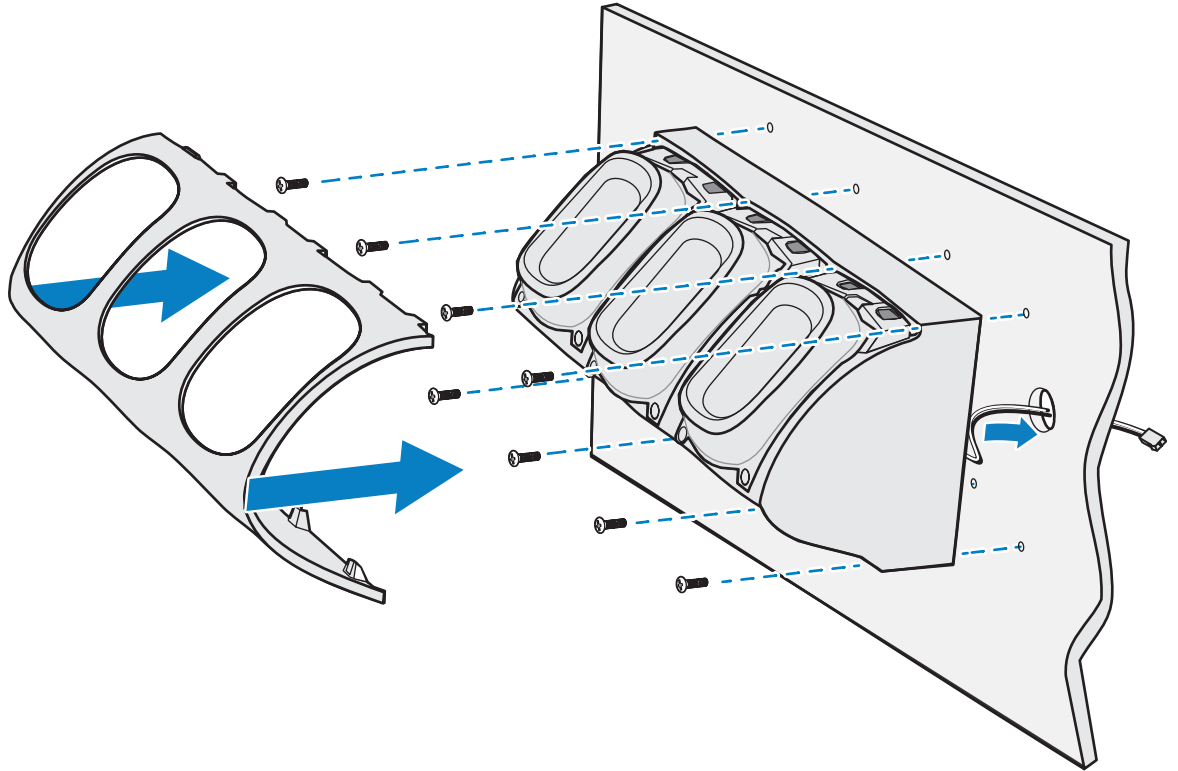

11. Connect the cables and power supply as shown.
 - a) Plug the Power Extension Cable (p/n CBL-MC18-EXINT1-01) to the interconnect cable (p/n 25-66431-01R).
 - b) Plug the “Y” cable (CBL-DC-392A1-02) to the Interconnect cables (p/n 25-66431-01R).
 - c) Plug the “Y” cable (CBL-DC-392A1-02) to the power supply unit.
 - d) Secure the power supply unit (p/n PWR-BGA12V108W0WW) to the back of the dispenser wall.
 - e) Connect the power cord to the power supply unit and to a 110/220 VAC outlet.

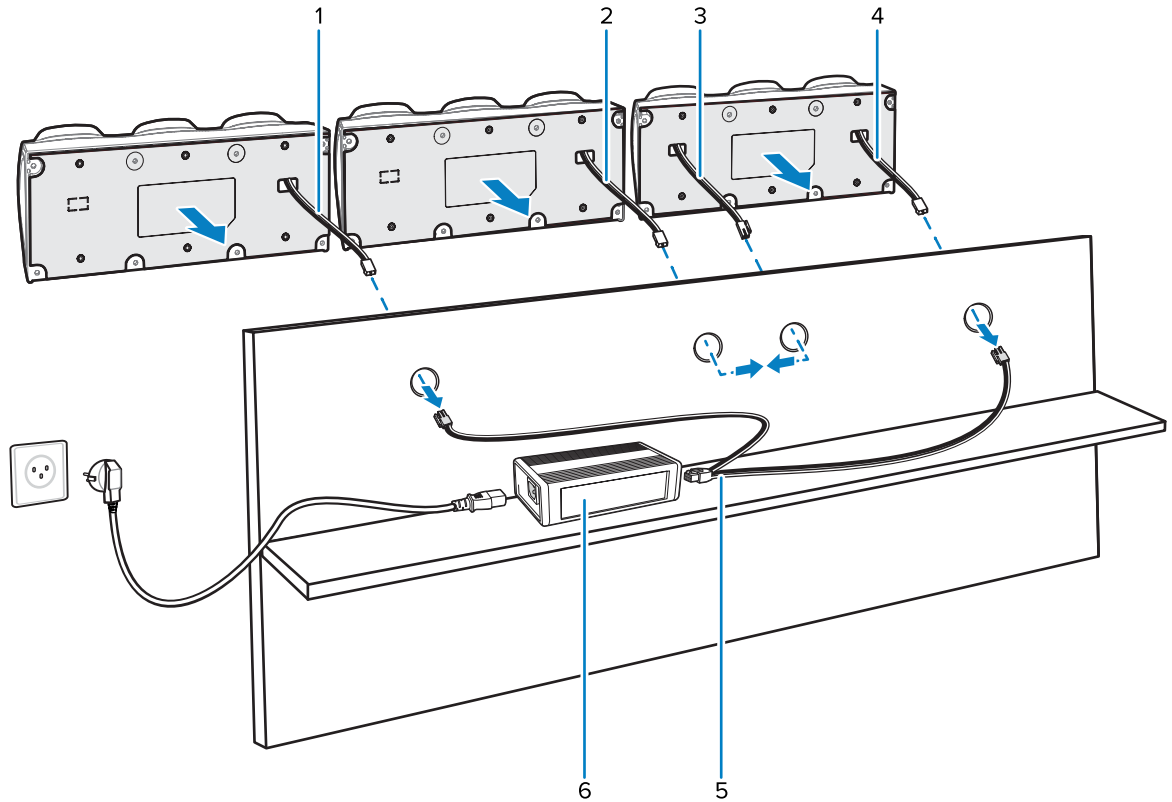

| | |
|---|---|
| 1 | Power extension cable (p/n CBL-MC18-EXINT1-01) |
| 2 | Power extension cable (p/n CBL-MC18-EXINT1-01) |
| 3 | Interconnect cable (p/n 25-66431-01R) |
| 4 | Cradle interconnection extension cable (p/n CBL-MC18-EXINT1-01) |
| 5 | DC “Y” charging cable long (CBL-DC-392A1-02) |
| 6 | Power supply unit (PWR-BGA12V108W0WW) |

12. Place the socket onto the cradle and secure the four screws.
13. Place the socket cover onto the cradle and secure the two screws.

Charging the Device

To achieve optimal charging results, use only Zebra charging accessories and batteries. Charge batteries at room temperature with the device in sleep mode.

The device or accessory always performs battery charging in a safe and intelligent manner. The device or accessory indicates when charging is disabled due to abnormal temperatures via its LED, and a notification appears on the device display.

The battery charges from 0 to 90% depending on the following conditions, measured at room temperature:

- In normal charge mode, the charge time is less than 4 hours.
- In fast charge mode, the charge time is less than 3 hours.

| Temperature | Battery Charging Behavior |
|----------------------|--|
| 0–40°C (32 to 104°F) | Optimal charging range. |
| Above 37°C (98°F) | The device or cradle may, for small periods of time, alternately enable and disable battery charging to keep the battery at acceptable temperatures. |

1. Connect the charging accessory to the appropriate power source.
2. Insert the device into a cradle.

Figure 29 3-Slot Cradle, Desktop Configuration

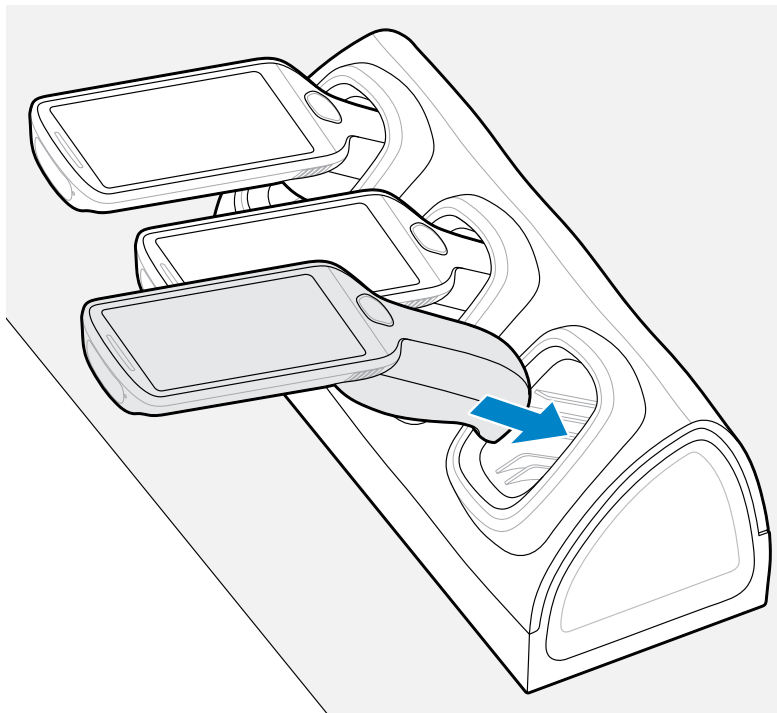

The device turns on and begins charging, and the LED status bar blinks green.

Releasing the Device from Locking Charging Cradles

Use one of the following methods to release the PS30 from locking charging cradles:

- [Software Release Using the Menu](#)
- [Software Release Using the Cradle Utility](#)
- [Manual Release Using a Release Key](#)



NOTE: Devices can also be removed via any customer application that uses the EMDK personal shopper interface.

Software Release Using the Menu

The device cradles contain a locking mechanism, which locks the device inside the cradle when the device is docked. The device releases from the cradle when a software command is received from the system.

1. Touch and hold .
2. Touch **Cradle unlock**.
The cradle unlocks the device.
3. Remove the device from the cradle.

Software Release Using the Cradle Utility

The device cradles contain a locking mechanism, which locks the device inside the cradle when the device is docked. The device releases from the cradle when a software command is received from the system.

1. On the Home screen, swipe up from the bottom of the screen.
2. Touch **CradleUtility**.
3. Tap the **CRADLE UNLOCK** tab to set the cradle unlock information.
4. Touch **Unlock Cradle**.
The cradle unlocks the device.
5. Remove the device from the cradle.

Manual Release Using a Release Key

The device cradles contain a locking mechanism, which locks the device inside the cradle when the device is docked. If the device fails to unlock during normal operation, use a release key (KT-MC18-CKEY-20) to unlock the device.



CAUTION: Do not use any device to unlock the cradle other than the tools described in this section. Failure to comply could result in damage to the cradle and void the warranty.

Manual Release from the 1-Slot Cradle

1. Insert the release key (1) into the slot located on the bottom of the cradle.

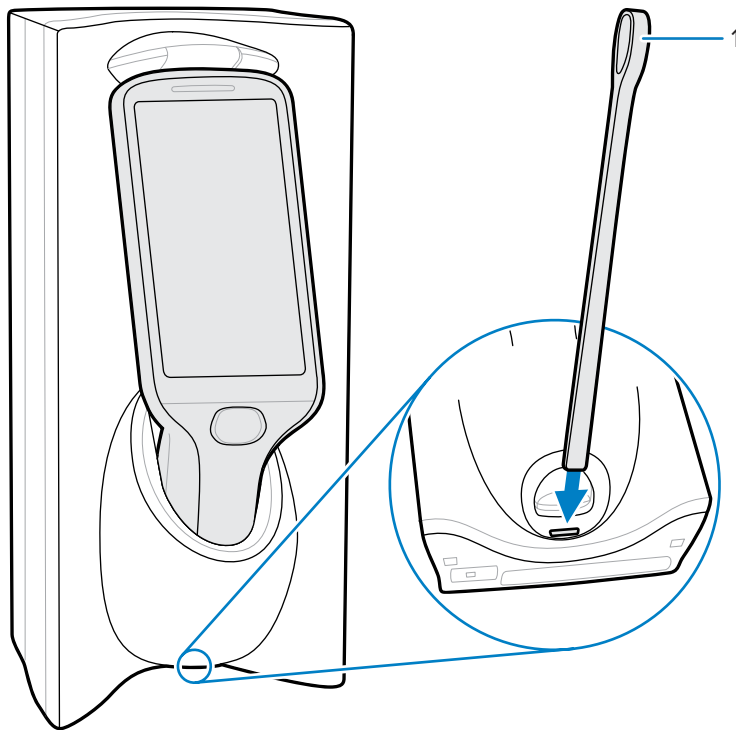

2. While pressing the release key all the way into the slot, remove the device from the cradle.

Manual Release from the 3-Slot Cradle

1. Insert the release key (1) straight into the slot in front of the device, to a point where the bend stops.

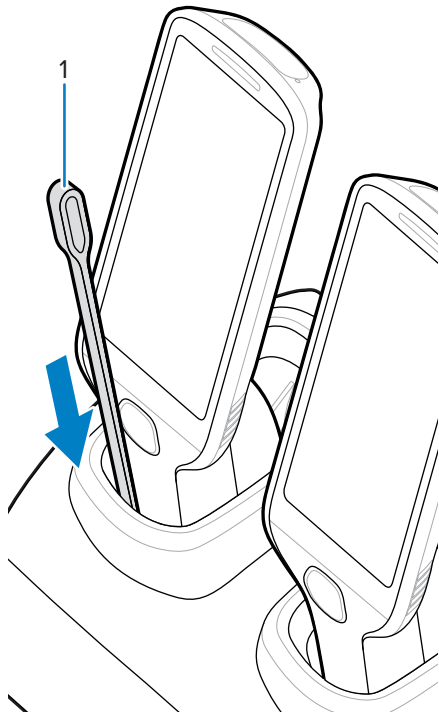

2. While holding the release key inside the slot, remove the device.

USB Programming Cable

The USB programming cable is attached to a battery cover. Use this cable to connect the device to a host computer.

Installing the USB Programming Cable

Use the USB programming cable to program and charge the PS30 personal shopper. This section provides instructions for installing the cable.

1. Touch and hold the scan key to wake the device.
2. Touch and hold .
3. Touch **Power off**.
4. Remove the standard battery cover that comes installed on the device, if it is not already removed.
 - a) Using a Phillips (PH00) screwdriver, loosen the captive screw that secures the battery cover.
 - b) Rotate the battery cover up, and remove it from the handle.

5. Slide the tab at the top of the battery cover with the USB programming cable into the slot on the back of the device.

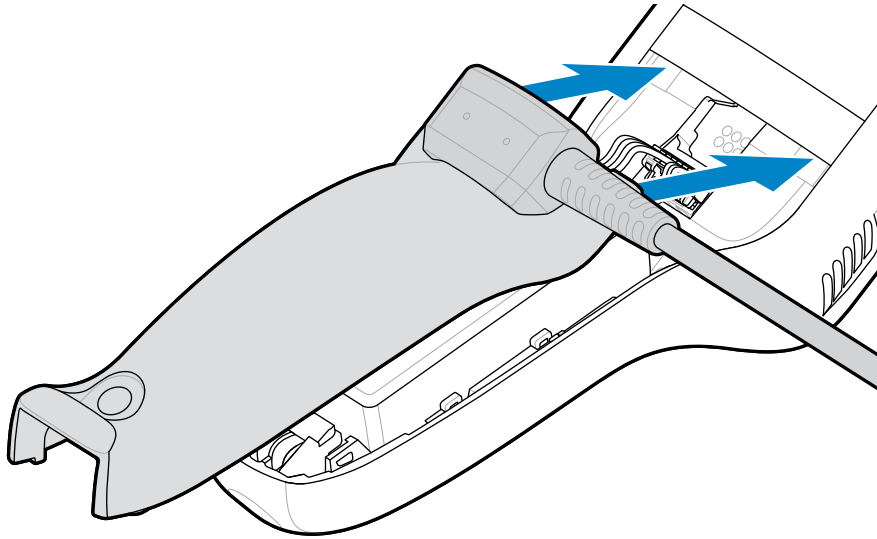

6. Push the bottom of the cover down until it snaps into place.

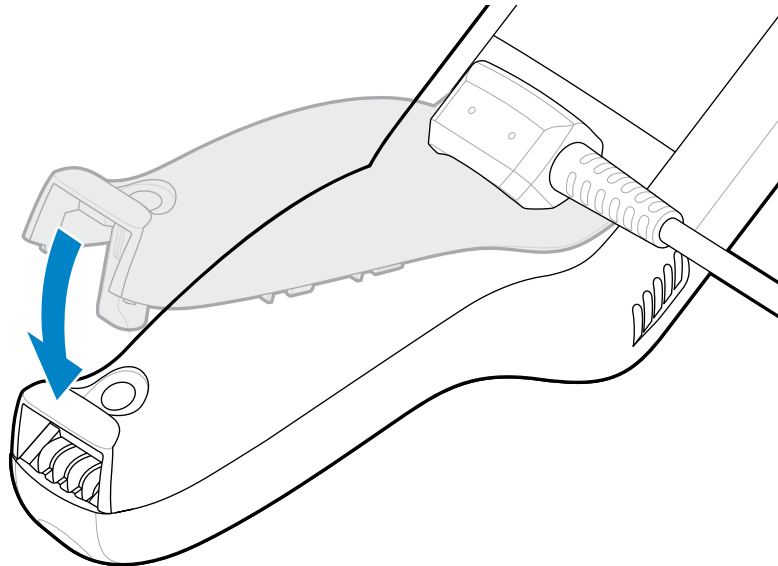

Connecting the Device to the Host Computer

The USB programming cable can be used to connect the device to a computer for charging or data exchange.

To connect the device to the host computer, insert the USB programming cable from the device into USB slot on the host computer.

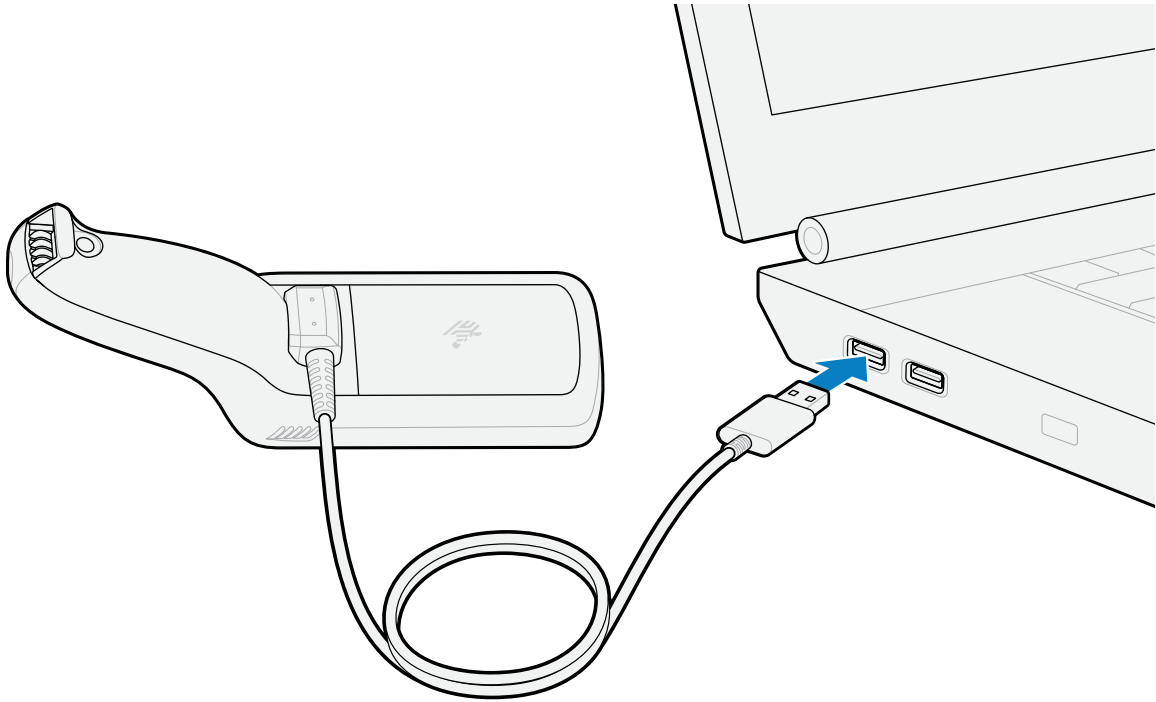

Removing the USB Programming Cable

This section provides instructions for removing the USB programming cable and reinstalling the device's battery cover.

1. Touch and hold the scan key to wake the device.
2. Touch and hold .
3. Touch **Power off**.
4. Rotate the battery cover portion of the programming cable up, and remove it from the handle.

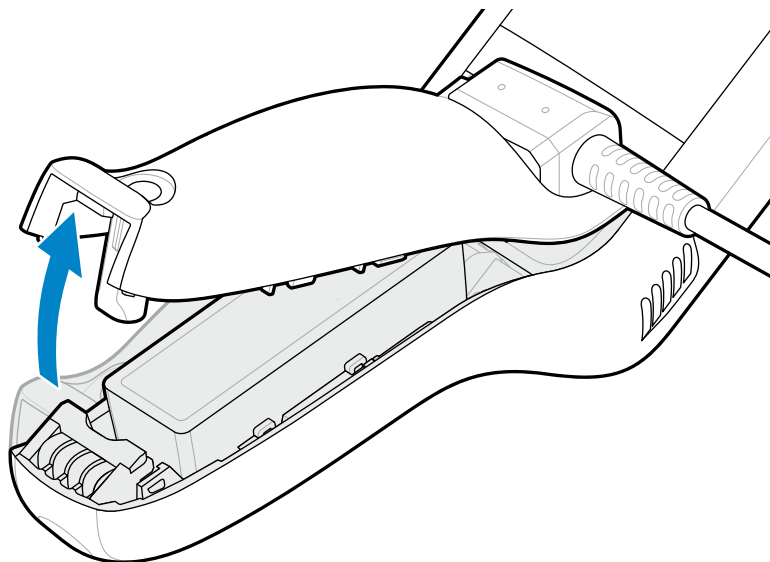

5. Insert the tabs on the battery cover into the handle, and then push the bottom of the battery cover down.

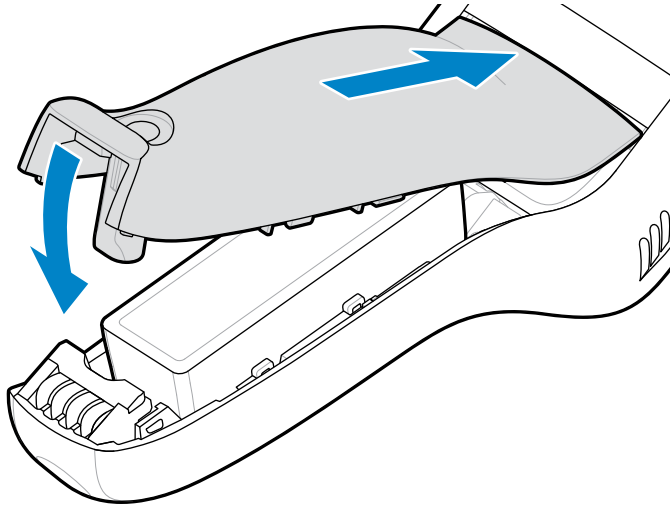

6. Using a Phillips (PH00) screwdriver, tighten the screw that secures the battery cover to the device.

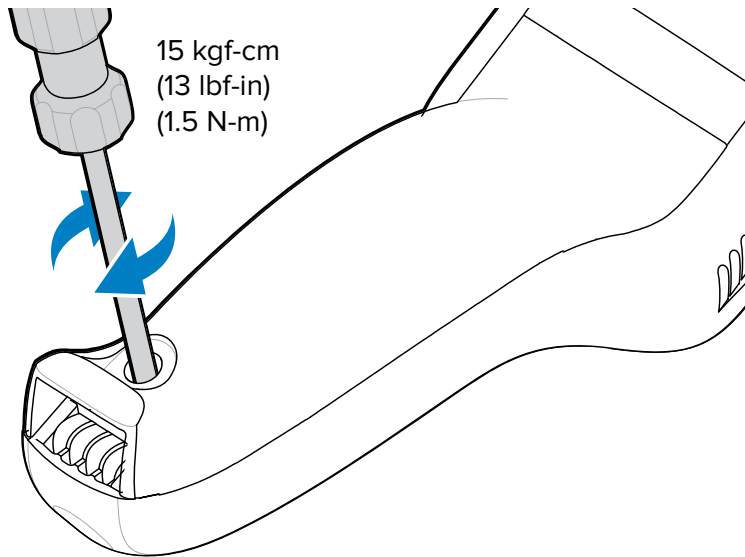

Soft Holster

The soft holster serves as a holder for the device. It allows you to wear the device on your hip (using a belt clip) or crossbody (using the detachable shoulder strap).

Always place the device with the correct orientation when using the soft holster with a belt clip or shoulder strap, as shown in the following diagrams.

Using the Belt Clip

Use a belt clip with a soft holster to wear the device on a belt or waistband.

1. Secure the belt clip on the soft holster, if it is not already attached.

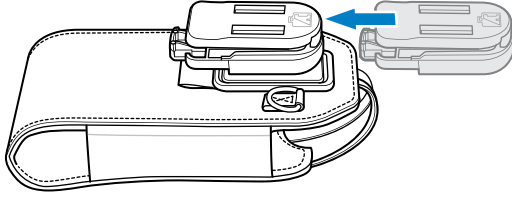

2. Secure the belt clip on the belt or waistband.

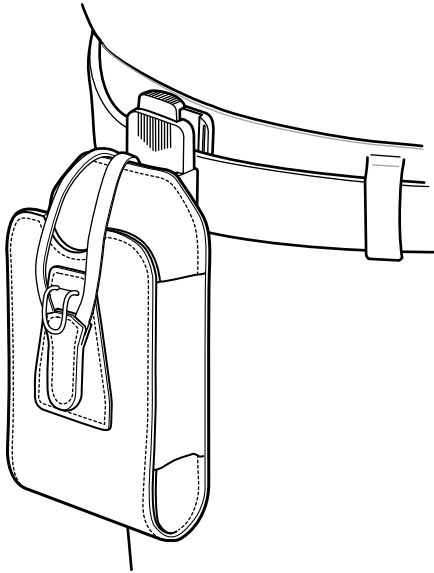

3. To insert the device, slide the device into the soft holster, with the screen facing you.

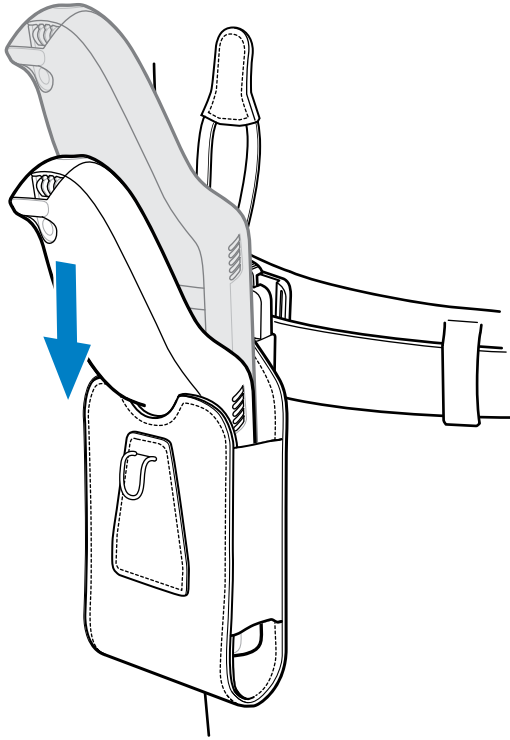

4. Pull the restraining strap over the device, and hook it to the bottom of the holster to secure the device in place.

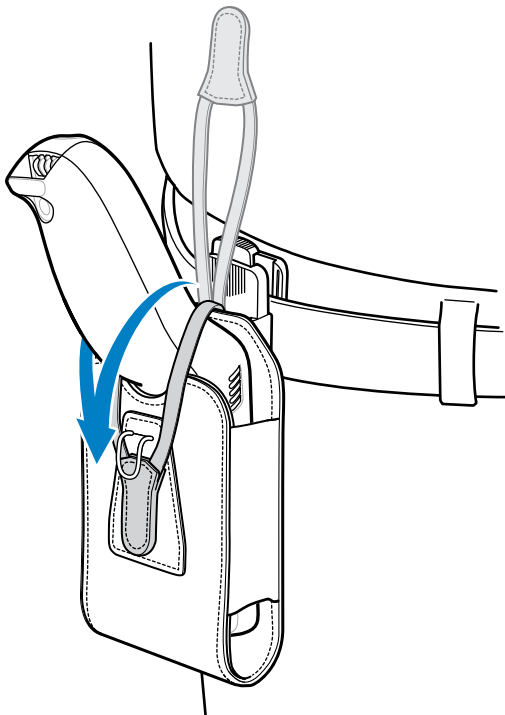

5. To remove the device, unhook and lift the restraining strap. Lift the device out of the soft holster.

Using the Shoulder Strap

Use a shoulder strap with a soft holster to wear the device crossbody.

1. Connect the clips on the shoulder strap to the rings on the soft holster, if not already attached.
2. Place the shoulder strap over your head, and rest the strap on your shoulder.

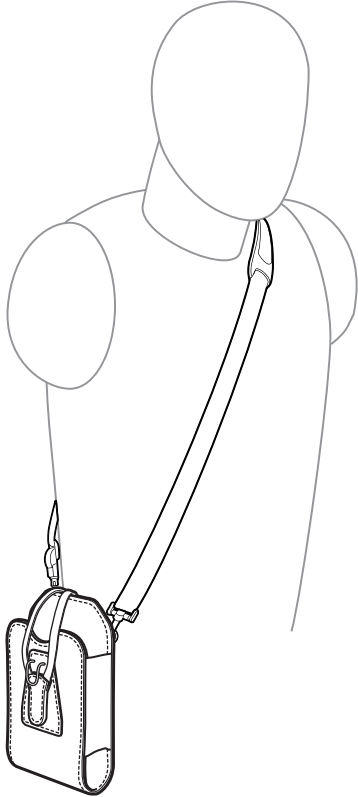

3. To insert the device, lift the strap and slide the device into the soft holster, with the screen facing you.

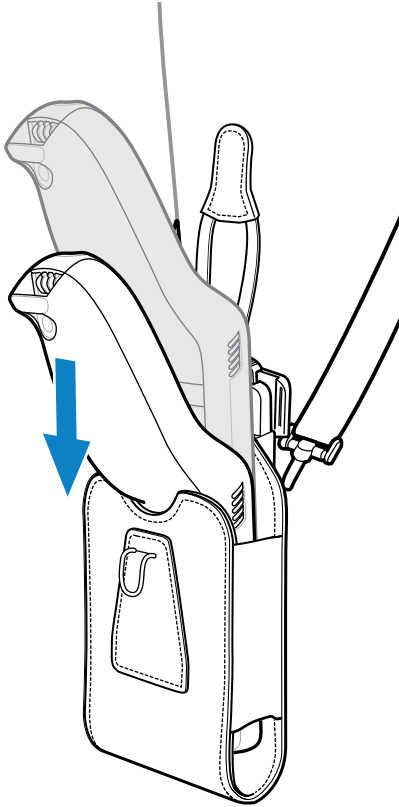

4. Pull the restraining strap over the device, and hook it to the bottom of the holster to secure the device in place.

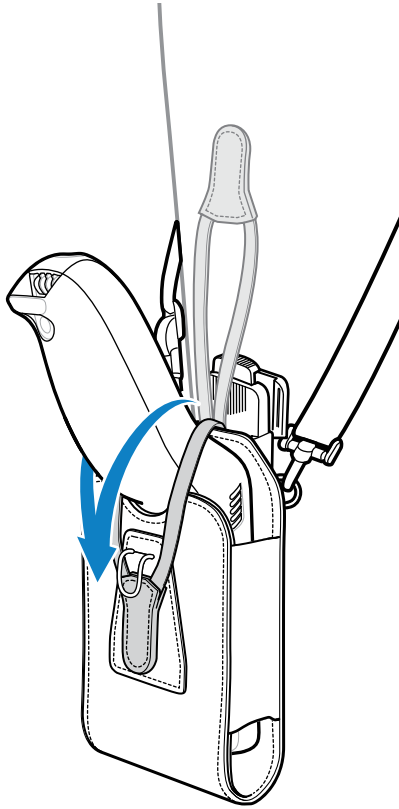

Application Deployment

This section provides steps on device security, app development, and app management. It also provides instructions for installing apps and updating the device software.



NOTE: Ensure that the date is set correctly before installing certificates or when accessing secure websites.

Security

The device implements a set of security policies that determine whether an application is allowed to run and, if allowed, with what level of trust. To develop an application, you must know the security configuration of the device, and how to sign an application with the appropriate certificate to allow the application to run (and to run with the needed level of trust).



NOTE: Ensure the date is set correctly before installing certificates or when accessing secure web sites.

Secure Certificates

If the VPN or Wi-Fi networks rely on secure certificates, obtain the certificates and store them in the device's secure credential storage before configuring access to the VPN or Wi-Fi networks.

If downloading the certificates from a web site, set a password for the credential storage. The device supports X.509 certificates saved in PKCS#12 key store files with a .p12 extension (if key store has a .pfx or other extension, change to .p12).

The device also installs any accompanying private key or certificate authority certificates contained in the key store.

Installing a Secure Certificate

If required by the VPN or Wi-Fi network, install a secure certificate on the device.

1. Copy the certificate from the host computer to the root of the device's internal memory.
2. Go to **Settings**.
3. Touch **Security > Encryption & credentials**.
4. Touch **Install a certificate**.
5. Navigate to the location of the certificate file.
6. Touch the filename of the certificate to install.

7. If prompted, enter the password for credential storage. If a password has not been set for the credential storage, enter a password for it twice, and then touch **OK**.
8. Enter a name for the certificate and in the Credential use drop-down, select **VPN and apps** or **Wi-Fi**.
9. Touch **OK**.

The certificate can now be used when connecting to a secure network. For security, the certificate is deleted from the internal memory.

Configuring Credential Storage Settings

Configure credential storage from the device settings.

1. Go to **Settings**.
2. Touch **Security > More security settings > Encryption & credentials**.
3. Select an option.
 - Touch **Trusted credentials** to display the trusted system and user credentials.
 - Touch **User credentials** to display user credentials.
 - Touch **Install from storage** to install a secure certificate from the internal storage.
 - Touch **Clear credentials** to delete all secure certificates and related credentials.

Android Development Tools

Development tools for Android include Android Studio, EMDK for Android, and StageNow.

Android Development Workstation

Android development tools are available at developer.android.com.

To start developing applications for the device, download Android Studio. Development can take place on a Microsoft® Windows®, Mac® OS X®, or Linux® operating system.

Applications are written in Java or Kotlin, but compiled and executed in the Dalvik virtual machine. Once the Java code is compiled cleanly, the developer tools make sure the application is packaged properly, including the AndroidManifest.xml file.

Android Studio contains a full featured IDE as well as SDK components required to develop Android applications.

Enabling Developer Options

The **Developer options** screen sets development-related settings. By default, the Developer Options are hidden.

1. Go to **Settings**.
2. Touch **About phone**.
3. Scroll down to **Build number**.
4. Tap **Build number** seven times.

The message **You are now a developer!** appears.

5. Touch **Back**.
6. Touch **System > Developer options**.
7. Slide the **USB debugging** switch to the **ON** position.

EMDK for Android

EMDK for Android provides developers with tools to create business applications for enterprise mobile devices. It is designed for use with Google's Android Studio and includes Android class libraries such as Barcode, sample applications with source code, and the associated documentation.

EMDK for Android allows applications to take full advantage of the capabilities that Zebra devices have to offer. It embeds Profile Manager technology within Android Studio IDE, providing a GUI-based development tool designed specifically for Zebra devices. This allows fewer lines of code, resulting in reduced development time, effort, and errors.

For more information, go to techdocs.zebra.com.

StageNow for Android

StageNow is Zebra's next-generation Android Staging Solution built on the MX platform. It allows quick and easy creation of device profiles and can deploy to devices simply by scanning a barcode or reading a tag.

The StageNow Staging Solution includes the following components:

- The StageNow Workstation tool installs on the staging workstation (host computer) and lets the administrator easily create staging profiles for configuring device components, and perform other staging actions such as checking the condition of a target device to determine suitability for software upgrades or other activities. The StageNow Workstation stores profiles and other created content for later use.
- The StageNow Client resides on the device and provides a user interface for the staging operator to initiate staging. The operator uses one or more of the desired staging methods (print and scan a barcode or read an NFC tag) to deliver staging material to the device.

For more information, go to techdocs.zebra.com.

GMS Restricted

GMS Restricted mode deactivates Google Mobile Services (GMS). All GMS apps are disabled on the device and communication with Google (analytics data collection and location services) is disabled.

Use StageNow to disable or enable GMS Restricted mode. After a device is in GMS Restricted mode, enable and disable individual GMS apps and services using StageNow. To ensure GMS Restricted mode persists after an Enterprise Reset, use the Persist Manager option in StageNow.

For more information on StageNow, go to techdocs.zebra.com.

ADB USB Setup

To use the Android Debug Bridge (ADB), install the development SDK on the host computer then install the ADB and USB drivers.

Before installing the USB driver, make sure that the development SDK is installed on the host computer. Go to developer.android.com/sdk/index.html for details on setting up the development SDK.

The ADB and USB drivers for Windows and Linux are available on the Zebra Support Central web site at zebra.com/support. Download the ADB and USB Driver Setup package. Follow the instructions with the package to install the ADB and USB drivers for Windows and Linux.

Enabling USB Debugging

By default, USB debugging is disabled.

1. Go to **Settings**.
2. Touch **About phone**.
3. Scroll down to **Build number**.
4. Tap **Build number** seven times.
The message **You are now a developer!** appears.
5. Touch **Back**.
6. Touch **System > Developer options**.
7. Slide the **USB debugging** switch to the **ON** position.
8. Touch **OK**.
9. Connect the device to the host computer using the Rugged Charge/USB Cable.

The **Allow USB debugging?** dialog box appears on the device.

If the device and host computer are connected for the first time, the **Allow USB debugging?** dialog box with the **Always allow from this computer** check box displays. Select the check box, if required.

10. Touch **OK**.
11. Touch **OK** or **Allow**.
12. On the host computer, navigate to the **platform-tools** folder and open a command prompt window.
13. Type `adb devices`.

The following displays:

```
List of devices attached          XXXXXXXXXXXXXXXXXX device
```

Where XXXXXXXXXXXXXXXXXX is the device number.



NOTE: If device number does not appear, ensure that ADB drivers are installed properly.

14. Return to the Home screen.

Application Installation Methods

After an application is developed, install the application onto the device using one of the supported methods.

- USB connection
- Android Debug Bridge
- Mobile device management (MDM) platforms that have application provisioning. Refer to the MDM software documentation for details.

Installing Applications Using the USB Connection

Use the USB connection to install applications onto the device.

1. Connect the device to a host computer using the USB Programming Cable. See [Installing the USB Programming Cable](#) on page 115 and [Connecting the Device to the Host Computer](#) on page 116.
2. On the device, pull down the Notification panel and touch **Charging this device via USB**.
By default, **No data transfer** is selected.
3. Touch **File Transfer**.
4. On the host computer, open a file explorer application.
5. On the host computer, copy the application APK file from the host computer to the device.
6. Disconnect the device from the host computer. See [Disconnecting from the Host Computer](#) on page 42.
7. Swipe the screen up and select  to view files on the Internal Storage.
8. Locate the application APK file.
9. Touch the application file.
10. Touch **Continue** to install the app or **Cancel** to stop the installation.
11. To confirm installation and accept what the application affects, touch **Install**. Otherwise, touch **Cancel**.
12. Touch **Open** to open the application or **Done** to exit the installation process.
The application appears in the App list.
13. Disconnect the USB programming cable. See [Removing the USB Programming Cable](#) on page 117.

Installing Applications Using the Android Debug Bridge

Use ADB commands to install applications onto the device.

1. Ensure that the ADB drivers are installed on the host computer.
2. Connect the device to a host computer using the USB Programming Cable. See [Installing the USB Programming Cable](#) on page 115 and [Connecting the Device to the Host Computer](#) on page 116.
3. Go to **Settings > System > Developer options**.
4. Slide the **USB debugging** switch to the **ON** position.
5. Touch **OK**.
6. If the device and host computer are connected for the first time, the **Allow USB debugging?** dialog box with the **Always allow from this computer** check box displays. Select the check box, if required.
7. Touch **OK** or **Allow**.
8. On the host computer, navigate to the **platform-tools** folder and open a command prompt window.
9. Type `adb install <application>`.
where: <application> = the path and filename of the apk file.
10. Disconnect the USB programming cable. See [Removing the USB Programming Cable](#) on page 117.

Uninstalling an Application

Free up device memory by removing unused apps.

1. Go to **Settings**.
2. Touch **Apps & notifications**.
3. Touch **See all apps** to view all apps in the list.
4. Scroll through the list to the app.
5. Touch the app.
The **App info** screen displays.
6. Touch **Uninstall**.
7. Touch **OK** to confirm.

Android System Update

System Update packages can contain either partial or complete updates for the operating system. Zebra distributes the System Update packages on the Zebra Support & Downloads website. Perform a system update using the USB Programming Cable and ADB.

Performing a System Update Using ADB

Use ADB to perform a system update.

1. Connect the device to a host computer using the USB Programming Cable. See [Installing the USB Programming Cable](#) on page 115 and [Connecting the Device to the Host Computer](#) on page 116.
2. Go to **Settings**.



NOTE: If you are unable to go to **Settings** because the device is locked, perform the steps in [Entering into Recovery Mode](#), and then proceed to the next step.

3. Touch **System > Developer options**.
4. Slide the **USB debugging** switch to the **ON** position.
5. Touch **OK**.
6. If the device and host computer are connected for the first time, the **Allow USB debugging?** dialog box with the **Always allow from this computer** check box displays. Select the check box, if required.
7. Touch **OK** or **Allow**.
8. On the host computer, navigate to the **platform-tools** folder and open a command prompt window.
9. Type `adb devices`.



NOTE: If the device number does not appear, ensure that the ADB drivers are installed properly.

10. Type `adb reboot recovery`.
11. Press **Enter**.
The System Recovery screen appears on the device.

12. Tap the touch panel to advance to the next menu choice and navigate to **apply upgrade from adb**.



IMPORTANT: If **Apply downgrade from ADB** is selected, an Enterprise Reset is performed on whatever upgrade or downgrade package is provided.

13. Press **Scan**.
14. Tap the touch panel to navigate to **Full OTA Package or Diff OTA Package**.
15. Press **Scan**.
16. On the host computer command prompt window type `adb sideload <file>`.
where: <file> = the path and filename of the zip file.
17. Press **Enter**.
The System Update installs (progress appears as a percentage in the Command Prompt window) and then the System Recovery screen appears on the device.
18. Press **Scan** to reboot the device.
19. Disconnect the USB programming cable. See [Removing the USB Programming Cable](#) on page 117.

Entering into Recovery Mode

Use the terminal reboot tool to place the device in Recovery Mode when you upgrade the device's software.

1. Insert the Terminal Reboot Tool into the Power Connector.
2. Press and hold the Scan key for 10 seconds until the display powers off.
3. Hold the Scan key and Terminal Reboot Tool for one to three seconds.
4. Release the Scan key.

The device enters into Recovery Mode.

Verifying System Update Installation

Verify that the system update was successful.

1. Go to **Settings**.
2. Touch **About phone**.
3. Scroll down to **Build number**.
4. Ensure that the build number matches the new system update package file number.

Android Enterprise Reset

An Enterprise Reset erases all user data in the /data partition, including data in the primary storage locations (/sdcard and emulated storage), while preserving the contents of the /enterprise folder and its subfolders. The contents of the /enterprise folder and its subfolders are preserved. Zebra distributes the Enterprise Reset packages on the Zebra Support & Downloads website.

Before performing an Enterprise Reset, provision all necessary configuration files and restore after the reset.

Performing an Enterprise Reset From Device Settings

Perform an Enterprise Reset from the device settings.

1. Go to **Settings**.
2. Touch **System** > **Reset Options** > **Erase all data (enterprise reset)**.
3. Touch **Erase all data** twice to confirm the Enterprise Reset.

Performing an Enterprise Reset Using ADB

Use the Android Debug Bridge to reset the device as part of a system update or debugging process.

1. Connect the device to a host computer using the USB Programming Cable. See [Installing the USB Programming Cable](#) on page 115 and [Connecting the Device to the Host Computer](#) on page 116.
2. Go to **Settings**.



NOTE: If you are unable to go to **Settings** because the device is locked, perform the steps in [Entering into Recovery Mode](#), and then proceed to the next step.

3. Touch **System** > **Developer options**.
4. Slide the **USB debugging** switch to the **ON** position.
5. Touch **OK**.
6. If the device and host computer are connected for the first time, the **Allow USB debugging?** dialog box with the **Always allow from this computer** check box displays. Select the check box, if required.
7. Touch **OK** or **Allow**.
8. On the host computer, navigate to the **platform-tools** folder and open a command prompt window.
9. Type `adb devices`.

The following displays:

```
List of devices attached
XXXXXXXXXXXXXXXXX device
```

Where XXXXXXXXXXXXXXXXXXXX is the device number.



NOTE: If the device number does not appear, ensure that the ADB drivers are installed properly.

10. Type `adb reboot recovery`.
11. Press **Enter**.
The System Recovery screen appears on the device.
12. Tap the touch panel to advance to the next menu choice and navigate to **Apply upgrade from ADB**.
13. Press **Scan**.
14. On the host computer command prompt window type `adb sideload <file>`
where: <file> = the path and filename of the zip file.
15. Press **Enter**.

The Enterprise Reset package installs and then the System Recovery screen appears on the device.

16. Press **Scan** to reboot the device.
17. Disconnect the USB programming cable. See [Removing the USB Programming Cable](#) on page 117.

Android Factory Reset

A Factory Reset erases all data in the /data and /enterprise partitions in internal storage and clears all device settings. A Factory Reset returns the device to the last installed operating system image. To revert to a previous operating system version, re-install that operating system image. Zebra distributes the Factory Reset packages on the Zebra Support & Downloads website.

Performing a Factory Reset Using ADB

Perform a Factory Reset using ADB.

1. Connect the device to a host computer using the USB Programming Cable. See [Installing the USB Programming Cable](#) on page 115 and [Connecting the Device to the Host Computer](#) on page 116.
2. Go to **Settings**.



NOTE: If you are unable to go to **Settings** because the device is locked, perform the steps in [Entering into Recovery Mode](#), and then proceed to **Settings**.

3. Touch **System** > **Developer options**.
4. Slide the **USB debugging** switch to the **ON** position.
5. Touch **OK**.
6. If the device and host computer are connected for the first time, the **Allow USB debugging?** dialog box with the **Always allow from this computer** check box displays. Select the check box, if required.
7. Touch **OK** or **ALLOW**.
8. Type `adb devices`.

The following displays:

```
List of devices attached
XXXXXXXXXXXXXXXXXX device
```

Where XXXXXXXXXXXXXXXXXXXX is the device number.



NOTE: If the device number does not appear, ensure that the ADB drivers are installed properly.

9. Type `adb reboot recovery`.
10. Press **Enter**.
The System Recovery screen appears on the device.
11. Tap the touch panel to advance to the next menu choice and navigate to **Apply upgrade from ADB**.
12. Press **Scan**.
13. On the host computer command prompt window type `adb sideload <file>`.
where: <file> = the path and filename of the zip file.

14. Press **Enter**.

The Factory Reset package installs, and then the System Recovery screen appears on the device.

15. Press **Scan** to reboot the device.
16. Disconnect the USB programming cable. See [Removing the USB Programming Cable](#) on page 117.

Android Storage

The device contains multiple types of file storage.

- Random Access Memory (RAM)
- On-device Storage
- Internal storage
- Enterprise folder.



NOTE: For more information, refer to Knowledge Articles - Best Practices in Mobile Computing: Flash at zebra.com/ps30-info.

Random Access Memory

Executing programs use RAM to store data. Data stored in RAM is lost upon a reset.

The operating system manages how applications use RAM. It only allows applications and component processes and services to use RAM when required. It may cache recently used processes in RAM, so they restart more quickly when opened again, but it will erase the cache if it needs the RAM for new activities.

The screen displays the amount of used and free RAM.

- **Performance** - Indicates memory performance.
- **Total memory** - Indicates the total amount of RAM available.
- **Average used (%)** - Indicates the average amount of memory (as a percentage) used during the period of time selected (default - 3 hours).
- **Free** - Indicates the total amount of unused RAM.
- **Memory used by apps** - Touch to view RAM usage by individual apps.

Viewing Memory

View the amount of memory used and free RAM.

1. Go to **Settings**.
2. Touch **System > Developer options**.
3. Touch **Memory**.

Internal Storage

The device has internal storage. The internal storage content can be viewed and files copied to and from when the device is connected to a host computer. Some applications are designed to be stored on the internal storage rather than in internal memory.

Viewing Internal Storage

View available and used internal storage on the device.

1. Go to **Settings**.
2. Touch **Storage**.

It displays the total amount of space on internal storage and amount used.

If the device has removable storage installed, touch **Internal shared storage** to display the amount of internal storage used by apps, photos, videos, audio, and other files.

Enterprise Folder

The Enterprise folder (within internal flash) is a super-persistent storage that is persistent after a reset and an Enterprise Reset.

The Enterprise folder is erased during a Factory Reset. The Enterprise folder is used for deployment and device-unique data. The Enterprise folder is approximately 128 MB (formatted). Applications can persist data after an Enterprise Reset by saving data to the enterprise/user folder. The folder is ext4 formatted and is only accessible from a host computer using ADB or from an MDM.

Managing Apps

Apps use two kinds of memory: storage memory and RAM. Apps use storage memory for themselves and any files, settings, and other data they use. They also use RAM when they are running.

1. Go to **Settings**.
2. Touch **Apps & notifications**.
3. Touch **See all XX apps** to view all apps on the device.
4. Touch **⋮ > Show system** to include system processes in the list.
5. Touch an app, process, or service in the list to open a screen with details about it and, depending on the item, to change its settings, permissions, notifications and to force stop or uninstall it.

App Details



Apps have different kinds of information and controls.

- **Force stop** - Stop an app.
- **Disable** - Disable an app.
- **Uninstall** - Remove the app and all of its data and settings from the device.
- **Notifications** - Set the app notification settings.
- **Permissions** - Lists the areas on the device that the app has access to.
- **Storage & cache** - Lists how much information is stored and includes buttons for clearing it.

- **Mobile data & Wi-Fi** - Provides information about data consumed by an app.
- **Advanced**
 - **Screen time** - Displays the amount of time the app has displayed on the screen.
 - **Battery** - Lists the amount of computing power used by the app.
 - **Open by default** - If you have configured an app to launch certain file types by default, you can clear that setting here.
 - **Display over other apps** - Allows an app to display on top of other apps.
 - **App details** - Provides a link to additional app details on the Play store.
 - **Additional settings in the app** - Opens settings in the app.
 - **Modify system settings** - Allows an app to modify the system settings.

Managing Downloads

Files and apps downloaded using the Browser or Email are stored in Internal storage in the Download directory. Use the Downloads app to view, open, or delete downloaded items.

1. Swipe the screen up and touch .
2. Touch  > **Downloads**.
3. Touch and hold an item to delete, and then touch .

The item is deleted from the device.

Maintenance and Troubleshooting

This section explains how to maintain and troubleshoot the device and accessories.

Maintaining the Device and Accessories

Follow these guidelines to maintain the device and accessories properly.

- To avoid scratching the screen, use a Zebra-approved, capacitive-compatible stylus intended for use with a touch-sensitive screen. Never use an actual pen, pencil, or other sharp object on the surface of the device screen.
- The device's touch-sensitive screen is made of glass. Do not drop the device or subject it to strong impact.
- Protect the device from temperature extremes. Do not leave it on the dashboard of a car on a hot day, and keep it away from heat sources.
- Do not store the device in any dusty, damp, or wet location.
- Use a soft lens cloth to clean the device. If the surface of the device screen becomes soiled, clean it with a soft cloth moistened with an approved cleanser.
- Periodically replace the rechargeable battery to ensure maximum battery life and product performance. Battery life depends on individual usage patterns.
- Periodically inspect accessory cables, connectors, and power supply units. Check the inside and outside of cradles to ensure good electrical contact. Replace any charging accessories that show signs of wear.

Battery Safety Guidelines

To use the device safely, you must follow the battery guidelines.

- The area in which the units are charged should be clear of debris and combustible materials or chemicals. Particular care should be taken when the device is charged in a non-commercial environment.
- Follow the battery usage, storage, and charging guidelines found in this guide.
- Improper battery use may result in a fire, explosion, or other hazard.
- To charge the mobile device battery, the ambient battery and charger temperatures must be between +32°F and +104°F (0°C and +40°C).

- Do not use incompatible batteries and chargers, including non-Zebra batteries and chargers. Use of an incompatible battery or charger may present a risk of fire, explosion, leakage, or other hazard. If you have any questions about the compatibility of a battery or a charger, contact the Global Customer Support Center.
- For devices that utilize a USB port as a charging source, the device shall only be connected to products that bear the USB-IF logo or have completed the USB-IF compliance program.
- Do not disassemble, open, crush, bend, deform, puncture, or shred the battery.
- Severe impact from dropping any battery-operated device on a hard surface could cause the battery to overheat.
- Do not short-circuit a battery or allow metallic or conductive objects to contact the battery terminals.
- Do not modify or remanufacture, attempt to insert foreign objects into the battery, immerse or expose to water or other liquids, or expose to fire, explosion, or other hazard.
- Do not leave or store the equipment in or near areas that might get very hot, such as in a parked vehicle or near a radiator or other heat source. Do not place a battery into a microwave oven or dryer.
- Battery usage by children should be supervised.
- Please follow local regulations to properly dispose of used rechargeable batteries.
- Do not dispose of batteries in a fire.
- In the event of a battery leak, do not allow the liquid to come in contact with the skin or eyes. If contact has been made, wash the affected area with water for 15 minutes, and seek medical advice.
- If you suspect damage to your equipment or battery, contact Customer Support to arrange for inspection.

Cleaning Instructions

Use caution and avoid damaging the device when using cleaning materials.



CAUTION: Always wear eye protection. Read the warning label on alcohol product before using. If you have to use any other solution for medical reasons please contact the Global Customer Support Center for more information.



WARNING: Avoid exposing this product to contact with hot oil or other flammable liquids. If such exposure occurs, unplug the device and clean the product immediately in accordance with these guidelines.

Approved Cleanser Active Ingredients

100% of the active ingredients in any cleaner must consist of one or some combination of the following: isopropyl alcohol, bleach/sodium hypochlorite (see important note below), hydrogen peroxide, ammonium chloride, or mild dish soap.²



IMPORTANT: Use pre-moistened wipes and do not allow liquid cleaner to pool.

² When using sodium hypochlorite (bleach) based products, always follow the manufacturer's recommended instructions: use gloves during application and remove the residue afterward with a damp alcohol cloth or a cotton swab to avoid prolonged skin contact while handling the device.

Due to the powerful oxidizing nature of sodium hypochlorite, the metal surfaces on the device are prone to oxidation (corrosion) when exposed to this chemical in the liquid form (including wipes). In the event that these types of disinfectants come in contact with metal on the device, prompt removal with an alcohol-dampened cloth or cotton swab after the cleaning step is critical.

Approved cleaners include:

- Purell Ethanol Wipes
- 409 Glass Cleaner
- Windex Blue
- Diversey D10 Disinfectant (1% concentration)

Harmful Ingredients

The following chemicals are known to damage the plastics on the device and should not come in contact with the device: acetone; ketones; ethers; aromatic and chlorinated hydrocarbons; aqueous or alcoholic alkaline solutions; ethanolamine; toluene; trichloroethylene; benzene; carboric acid and TB-lysoform.

Many vinyl gloves contain phthalate additives, which are often not recommended for medical use and are known to be harmful to the housing of the device.

Device Cleaning Instructions

Do not apply liquid directly to the device. Dampen a soft cloth or use pre-moistened wipes. Do not wrap the device in the cloth or wipe, instead gently wipe the unit. Be careful not to let liquid pool around the display window or other places. Before use, allow the unit to air dry.



NOTE: For thorough cleaning, it is recommended to first remove all accessory attachments, such as hand straps or cradle cups from the mobile device and to clean them separately.

Special Cleaning Notes

Do not handle the device while wearing vinyl gloves containing phthalates. Remove vinyl gloves and wash hands to eliminate any residue left from the gloves.

If products containing any of the harmful ingredients listed above are used prior to handling the device, such as a hand sanitizer that contains ethanolamine, hands must be completely dry before handling the device to prevent damage to the device.



IMPORTANT: If the battery connectors are exposed to cleaning agents, thoroughly wipe off as much of the chemical as possible and clean with an alcohol wipe. It is also recommended to install the battery in the terminal prior to cleaning and disinfecting the device to help minimize buildup on the connectors. When using cleaning/disinfectant agents on the device, it is important to follow the directions prescribed by the cleaning/disinfectant agent manufacturer.

Cleaning Materials Required

- Alcohol wipes with 70% isopropyl alcohol
- Lens tissue
- Cotton-tipped applicators
- 70% Isopropyl alcohol

- Can of compressed air for electronics with a dispenser tube

Cleaning Frequency

The cleaning frequency is at the customer's discretion due to the varied environments in which the mobile devices are used and may be cleaned as frequently as required. When dirt is visible, it is recommended to clean the mobile device to avoid the build-up of particles, which makes the device more difficult to clean later on.

For consistency and optimum image capture, it is recommended to clean the exit window periodically, especially when used in environments prone to dirt or dust.

Cleaning the Device

This section describes how to clean the housing, display, and exit window for the device.

Housing

Thoroughly wipe the housing, including all buttons and triggers, using an approved alcohol wipe.

Display

The display can be wiped down with an approved alcohol wipe, but care should be taken not to allow any pooling of liquid around the edges of the display. Immediately dry the display with a soft, non-abrasive cloth to prevent streaking.

Exit Window

Wipe the exit window periodically with lens tissue or other material suitable for cleaning optical material such as eyeglasses.

Cleaning Battery Connectors

1. Remove the main battery from the mobile computer.
2. Dip the cotton portion of the cotton-tipped applicator in isopropyl alcohol.
3. To remove any grease or dirt, rub the cotton portion of the cotton-tipped applicator back and forth across the connectors on the battery and terminal sides. Do not leave any cotton residue on the connectors.
4. Repeat at least three times.
5. Use a dry cotton-tipped applicator and repeat steps 3 and 4. Do not leave any cotton residue on the connectors.
6. Inspect the area for any grease or dirt and repeat the cleaning process if necessary.



CAUTION: After cleaning the battery connectors with bleach-based chemicals, follow the Battery Connector Cleaning instructions to remove bleach from the connectors.

Cleaning Cradle Connectors

1. Remove the DC power cable from the cradle.

2. Dip the cotton portion of the cotton-tipped applicator in isopropyl alcohol.
3. Rub the cotton portion of the cotton-tipped applicator along the pins of the connector. Slowly move the applicator back and forth from one side of the connector to the other. Do not leave any cotton residue on the connector.
4. All sides of the connector should also be rubbed with the cotton-tipped applicator.
5. Remove any lint left by the cotton-tipped applicator.
6. If grease and other dirt can be found on other areas of the cradle, use a lint-free cloth and alcohol to remove.
7. Allow at least 10 to 30 minutes (depending on ambient temperature and humidity) for the alcohol to air dry before applying power to cradle.

If the temperature is low and humidity is high, longer drying time is required. Warm temperature and low humidity requires less drying time.



CAUTION: After cleaning the cradle connectors with bleach-based chemicals, follow the Cleaning Cradle Connectors instructions to remove bleach from the connectors.

Troubleshooting

In rare circumstances, to troubleshoot the device, you may need to reset the device.

Resetting the Device

This section describes options to reset the device.

There are four reset functions:

- Soft reset
- Hard reset
- Enterprise reset.
- Factory reset.

Performing a Soft Reset

Perform a soft reset if applications stop working.

1. Press and hold the soft **Power** button until the menu appears.
2. Touch **Restart**.

The device reboots.

Performing a Hard Reset - Device in Cradle



CAUTION: Perform a hard reset only if the device stops responding.

1. Ensure power is applied to the cradle.
2. Press and hold the Scan key for 10 seconds until the display powers off.
3. Release the Scan key.

4. Briefly press and release the Scan key.

The device reboots.

Performing a Hard Reset - Device Out of Cradle



CAUTION: Perform a hard reset only if the device stops responding.

1. Insert the Terminal Reboot Tool into the Power Connector.

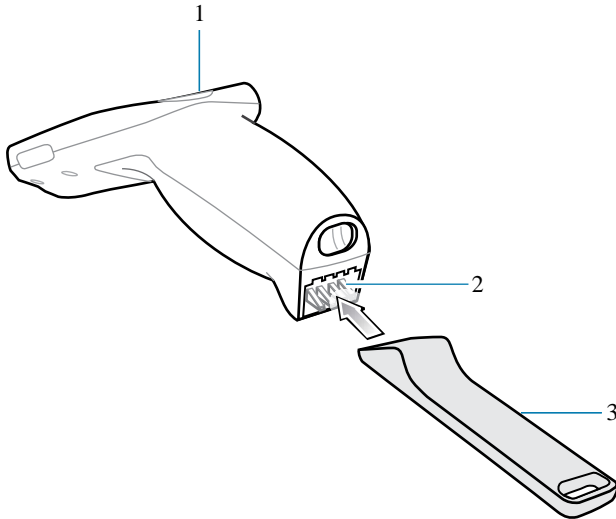

| | |
|---|----------------------|
| 1 | Scan key |
| 2 | Power connector |
| 3 | Terminal reboot tool |

2. Press and hold the Scan key for 10 seconds until the display powers off.
3. Release the Scan key.
4. Remove the Terminal Reboot Tool.

The device reboots.

Entering into Recovery Mode

Use the terminal reboot tool to place the device in Recovery Mode when you upgrade the device's software.

1. Insert the Terminal Reboot Tool into the Power Connector.
2. Press and hold the Scan key for 10 seconds until the display powers off.
3. Hold the Scan key and Terminal Reboot Tool for one to three seconds.
4. Release the Scan key.

The device enters into Recovery Mode.

Troubleshooting the Device

Provides solutions to common device issues.

Table 19 Troubleshooting the Device

| Problem | Cause | Solution |
|--|---|--|
| When pressing the power button the device does not turn on. | The battery is not charged. | Charge or replace the battery in the device. |
| | The battery is not installed properly. | Install the battery properly. |
| | System crash. | Perform a soft reset. If the device still does not turn on, perform a hard reset. |
| The battery did not charge. | Battery failed. | Replace battery. If the device still does not operate, perform a reset. |
| | The device was removed from the cradle while the battery was charging. | Insert the device in the cradle. The battery fully charges in approximately four hours. |
| | Extreme battery temperature. | The battery does not charge if the ambient temperature is below 0°C (32°F) or above 40°C (104°F). |
| During data communication with a host computer, no data transmitted, or transmitted data was incomplete. | The device was removed from the cradle or was disconnected from the host computer during communication. | Replace the device in the cradle, or reattach the communication cable and retransmit. |
| | Incorrect cable configuration. | See the system administrator. |
| | Communication software was incorrectly installed or configured. | Perform setup. |
| The device shuts off. | The device is inactive. | When the device ships, by default, the Sleep period is Never. If the device is running on battery power, this period can be changed to 15 seconds, 30 seconds, 1 minute, 2 minutes, 5 minutes, 10 minutes, or 30 minutes. The device turns off after the set period of inactivity. Change the setting if you need a longer delay before the automatic shutoff feature activates. |
| | The battery is depleted. | Replace the battery. |
| | The battery is not inserted properly. | Install the battery properly. |
| | The device's battery is low and it powers down to protect memory content. | Place the device in the cradle to recharge the battery. |

Table 19 Troubleshooting the Device (Continued)

| Problem | Cause | Solution |
|---|--|---|
| A message appears stating that the device's memory is full. | Too many files are stored on the device. | Delete unused memos and records. If necessary, save these records on the host computer (or use an SD card for additional memory). |
| | Too many applications are installed on the device. | Remove user-installed applications on the device to recover memory. Select Storage > FREE UP SPACE > REVIEW RECENT ITEMS . Select the unused program(s), and then touch FREE UP . |

Cradle Troubleshooting

Provides solutions to common cradle issues.

Table 20 Cradle Troubleshooting

| Symptom | Possible Cause | Action |
|---|--|---|
| The device battery is not charging. | The device was removed from the cradle or the cradle was unplugged from the AC power too soon. | Ensure that the cradle is receiving power. Ensure that the device is seated correctly. Confirm that the main battery is charging. The battery fully charges in approximately 4 hours. |
| | The battery is faulty. | Verify that other batteries charge properly. If so, replace the faulty battery. |
| | The device is not fully seated in the cradle. | Remove and re-insert the device into the cradle, ensuring it is firmly seated. |
| | Extreme battery temperature. | The battery does not charge if the ambient temperature is below 0°C (32°F) or above 40°C (104°F). |
| When the device is placed in the cradle, the cradle LED does not blink. | The cradle is not powered. | Ensure that the cradle is receiving power. |
| | The cradle firmware is corrupted. | Contact the system administrator. |
| | The device is not operational. | Contact the system administrator. |
| | Communication error between the cradle and device. | Contact the system administrator. |
| The cradle LED blinks red. | The cradle is issued an unlock command and it fails to unlock. | Contact the system administrator. |
| | The cradle is overheating due to continuous lock/unlock or other cradle faults. | Contact the system administrator. |

Specifications

For device technical specifications, go to www.zebra.com.

Data Capture Supported Symbologies

This table shows the data capture supported symbologies.

| Item | Description |
|-------------|--|
| 1D Barcodes | Code 39, Code 128, Code 93, Codabar, MSI, UPC/EAN, Interleaved 2 of 5, RSS, Composite, TLC-39 |
| 2D Barcodes | PDF-417, Micro PDF-417, Composite, TLC-39, Datamatrix, DotCode, QR Code, Micro QRCode, Maxicode, Postal codes, Aztec Code, Han Xin |

Interface Connector Pin-Outs

The interface connector pin-outs are located at the end of the device handle.

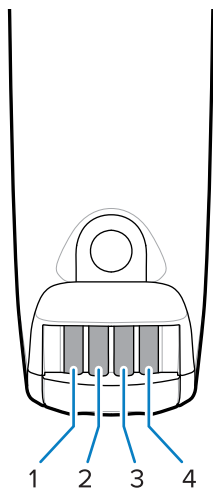

Table 21 Power Connector Pin-Outs

| Pin | Signal | Description |
|-----|--------|-------------|
| 1 | GND | Ground |

Table 21 Power Connector Pin-Outs (Continued)

| Pin | Signal | Description |
|-----|--------|---------------------------|
| 2 | RX | Receive Input from Cradle |
| 3 | TX | Transmit Output to Cradle |
| 4 | +5V | Input power |

Accessory Specifications

This section describes the device's accessory specifications.

1-Slot Cradle Technical Specifications

This table shows the technical specifications for the 1-slot cradle.

| Item | Description |
|-------------------------------|---|
| Operating Temperature | 0°C to 40°C (32°F to 104°F) |
| Storage Temperature | -20°C to 60°C (-4°F to 140°F) |
| Battery Charging Temperature | 0°C to 40°C (32°F to 104°F) ambient temperature |
| Humidity | 10% to 95% non-condensing |
| Size (L x W x H) | 98 mm x 127 mm x 272 mm (4 in. x 5 in. x 10.7 in.) |
| Weight | 620 g (21.87 oz) |
| Power Supply | 12.0 VDC, 9.0 A |
| Electrostatic Discharge (ESD) | +/- 15 k VDC air discharge +/- 8 k VDC contact discharge |

3-Slot Cradle Technical Specifications

This table shows the technical specifications for the 3-slot cradle.

Table 22 3-Slot Cradle Technical Specifications

| Item | Description |
|------------------------------|--|
| Operating Temperature | 0°C to 40°C (32°F to 104°F) |
| Storage Temperature | -20°C to 60°C (-4°F to 140°F) |
| Battery Charging Temperature | 0°C to 40°C (32°F to 104°F) ambient temperature |
| Humidity | 10% to 95% non-condensing |
| Size (L x W x H) | 129 mm x 134 mm x 310 mm (5 in x 5.2 in x 12.2 in) |
| Weight | 1550 g (54.67 oz) |
| Power Supply | 12.0 VDC, 9.0 A |

Table 22 3-Slot Cradle Technical Specifications (Continued)

| Item | Description |
|-------------------------------|---|
| Electrostatic Discharge (ESD) | +/- 15 k VDC air discharge +/- 8 k VDC contact discharge |

Cable Specifications

This section describes the device's cable specifications.

Power Supply Cable, Y-type Specifications

The 16 AWG wire should have the following specifications: UL1007, 300 Volt, PVC, -40° C to 80° C operating temperature.

Table 23 Wire Run List & Specifications

| Wire Color | AWG | Connector 1 Molex 39-01-2060 housing; 4x, 39-00-0211 contacts | Connector 2 Molex 39-01-2025 housing; 2x, 39-00-0211 contacts | Connector 3 Molex 39-01-2025 housing; 2x, 39-00-0211 contacts | Function |
|------------|-----|---|---|---|----------|
| Red | 16 | 1 | 1 | | (+) term |
| Black | 16 | 6 | 2 | | (-) term |
| Red | 16 | 2 | | 1 | (+) term |
| Black | 16 | 5 | | 2 | (-) term |

Cradle Interconnection Cable Specifications

The 16 AWG wire should have the following specifications: UL1007, 300 Volt, PVC, -40° C to 80° C operating temperature.

Table 24 Wire Run List & Specifications

| Wire Color | AWG | Connector 1 Molex 39-01-2025 housing; 2x, 39-00-0211 contacts | Connector 2 Molex 39-01-2025 housing; 2x, 39-00-0211 contacts | Function |
|------------|-----|---|---|----------|
| Red | 16 | 1 | 1 | (+) term |
| Black | 16 | 2 | 2 | (-) term |

