

Zebra 4Sight XV7



ZEBRA

Product Reference Guide

2025/12/01

ZEBRA and the stylized Zebra head are trademarks of Zebra Technologies Corporation, registered in many jurisdictions worldwide. All other trademarks are the property of their respective owners. ©2025 Zebra Technologies Corporation and/or its affiliates. All rights reserved.

Information in this document is subject to change without notice. The software described in this document is furnished under a license agreement or nondisclosure agreement. The software may be used or copied only in accordance with the terms of those agreements.

For further information regarding legal and proprietary statements, please go to:

SOFTWARE: zebra.com/informationpolicy.

COPYRIGHTS: zebra.com/copyright.

PATENTS: ip.zebra.com.

WARRANTY: zebra.com/warranty.

END USER LICENSE AGREEMENT: zebra.com/eula.

Terms of Use

Proprietary Statement

This manual contains proprietary information of Zebra Technologies Corporation and its subsidiaries ("Zebra Technologies"). It is intended solely for the information and use of parties operating and maintaining the equipment described herein. Such proprietary information may not be used, reproduced, or disclosed to any other parties for any other purpose without the express, written permission of Zebra Technologies.

Product Improvements

Continuous improvement of products is a policy of Zebra Technologies. All specifications and designs are subject to change without notice.

Liability Disclaimer

Zebra Technologies takes steps to ensure that its published Engineering specifications and manuals are correct; however, errors do occur. Zebra Technologies reserves the right to correct any such errors and disclaims liability resulting therefrom.

Limitation of Liability

In no event shall Zebra Technologies or anyone else involved in the creation, production, or delivery of the accompanying product (including hardware and software) be liable for any damages whatsoever (including, without limitation, consequential damages including loss of business profits, business interruption, or loss of business information) arising out of the use of, the results of use of, or inability to use such product, even if Zebra Technologies has been advised of the possibility of such damages. Some jurisdictions do not allow the exclusion or limitation of incidental or consequential damages, so the above limitation or exclusion may not apply to you.

About this Guide

This guide provides information on using the Zebra 4Sight XV7.

Notational Conventions

The following notational conventions make the content of this document easy to navigate.

- **Bold** text is used to highlight the following:
 - Dialog box, window, and screen names
 - Dropdown list and list box names
 - Checkbox and radio button names
 - Icons on a screen
 - Key names on a keypad
 - Button names on a screen
- Bullets (•) indicate:
 - Action items
 - List of alternatives
 - Lists of required steps that are not necessarily sequential
- Sequential lists (for example, those that describe step-by-step procedures) appear as numbered lists.

Icon Conventions

The documentation set is designed to give the reader more visual clues. The following visual indicators are used throughout the documentation set.



NOTE: The text here indicates information that is supplemental for the user to know and that is not required to complete a task.



IMPORTANT: The text here indicates information that is important for the user to know.



CAUTION: If the precaution is not heeded, the user could receive a minor or moderate injury.



WARNING: If danger is not avoided, the user CAN be seriously injured or killed.



DANGER: If danger is not avoided, the user WILL be seriously injured or killed.

Service Information

If you have a problem with your equipment, contact Zebra Global Customer Support for your region. Contact information is available at: zebra.com/support.

When contacting support, please have the following information available:

- Serial number of the unit
- Model number or product name
- Software/firmware type and version number

Zebra responds to calls by email, telephone, or fax within the time limits set forth in support agreements.

If your problem cannot be solved by Zebra Customer Support, you may need to return your equipment for servicing and will be given specific directions. Zebra is not responsible for any damages incurred during shipment if the approved shipping container is not used. Shipping the units improperly can possibly void the warranty.

If you purchased your Zebra business product from a Zebra business partner, contact that business partner for support.

Getting Started

The Zebra 4Sight XV7 unit is an expandable vision controller (imaging computer) that integrates processing and display capabilities, along with image capture from USB3 Vision and/or GigE Vision cameras. Zebra 4Sight XV7 supports networking and industrial communication (over GigE Ethernet ports or RS-232 ports connected through the serial port headers)¹. There are also additional PCIe, M.2, and RAM slots available to add additional boards, storage, and memory, respectively.



Zebra 4Sight XV7 includes a motherboard, UDIMM memory modules, an M.2 solid state mass storage device and two fans, all of which are encased within a rugged metal chassis. You can install Zebra or third-party full-height, half-length PCIe boards in the Zebra 4Sight XV7 unit (such as frame grabbers and I/O boards).

¹ The PROFINET protocol is not supported natively. For support, you can install a Zebra board that supports hardware-assisted PROFINET communication (such as Zebra Indio).

Figure 1 Zebra XV7 motherboard

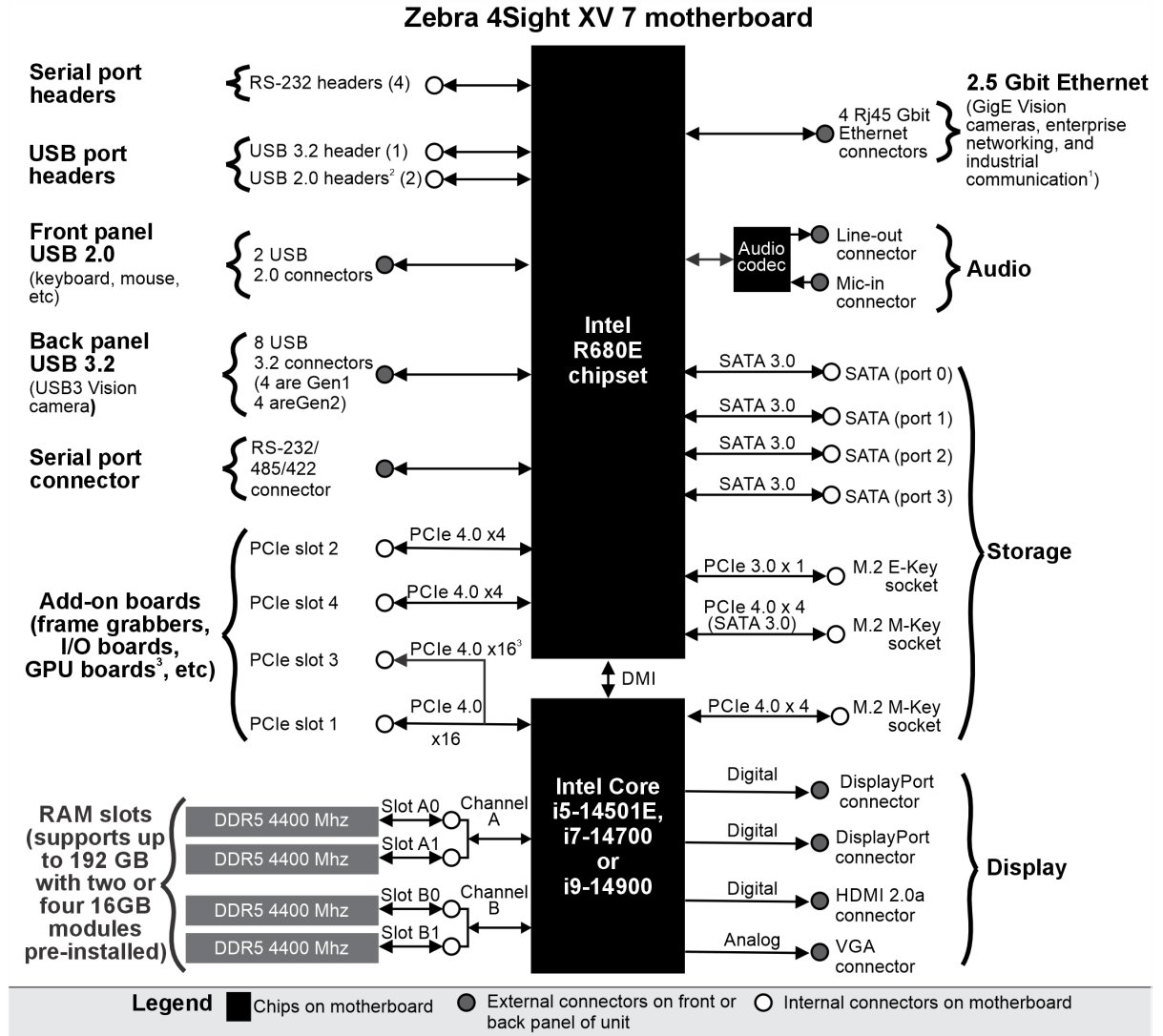

1 Note that the PROFINET protocol and PoE are not supported.

2 Note that the two USB 2.0 connectors on the front panel are already connected to one of the three USB 2.0 headers.

3 Note that this slot is mechanically x16, but electrically it only supports x8 PCIe lanes. 8 lanes are shared with Slot 1, so if you use a board in Slot 3, then Slot 1 will only support x8 lanes.

Unpacking

The following tables list standard items that are included in the Zebra 4Sight XV7 package, as well as additional items that are available from Zebra. If anything is missing or damaged, contact Zebra for assistance.

Standard Items

Your Zebra 4Sight XV7 package should include the following standard items:

Standard package item	Details
Zebra 4Sight XV7	<p>Encases the following components:</p> <ul style="list-style-type: none"> • The Zebra 4Sight XV7 motherboard. • An i5-14501E, i7-14700, or i9-14900 Intel CPU. • 32 or 64 Gbytes of DDR5 non-ECC UDIMM RAM. • An M.2 connected 256-Gbyte NVME SSD. • Two cooling fans: one fan for the CPU and one fan for the unit. • 600W AC or 24V DC power supply.
Zebra 4Sight XV7 power cable	<ul style="list-style-type: none"> • Standard AC power cable for your region (US, EU, or UK).
Zebra 4Sight XV7 software package	<p>Includes the following:</p> <ul style="list-style-type: none"> • An operating system license (Windows only). • Drivers and utilities. These are pre-installed, but if you require their installation files, contact your Zebra representative.
Regulatory guide	A booklet that includes regulatory information and warning symbols related to your unit.

Additional Components

Additional component	Details
Zebra frame grabbers and Zebra industrial communication and I/O boards.	Contact your Zebra sales representative for availability.
Zebra video, GigE, and USB cables	Used to connect video sources to Zebra 4Sight XV7 units or Zebra frame grabber boards. Contact your Zebra sales representative for availability.
Zebra 4Sight XV7 accessory parts	<ul style="list-style-type: none"> • Two SATA3 cables. • Two mounting brackets. • Bag of screws (these are used to mount up to two 2.5" drives onto the drive bracket found inside the chassis) • Four rubber pads for the base of the unit.

Operating System Overview

Zebra 4Sight XV7 comes pre-installed with either Microsoft Windows or Linux.



NOTE: When secure boot is enabled, ensure all installed drivers are properly signed for operating with the secure boot. If your drivers are not properly signed to operate with secure boot, you might have driver issues (for example, driver issues with USB devices). See the documentation accompanying the operating system for more information.

Be aware that each end user is responsible for secure configuration, patch management, and overall security of the system. It is up to the end user to obtain and apply any necessary patches and updates that are made available through the update service offered by the operating system (for example, Windows Update).

Windows

If you have a Windows SKU, your Zebra XV7 is pre-installed with Microsoft Windows 11 IoT Enterprise 2024 (64-bit version). Zebra Technologies designed the Zebra 4Sight XV7 unit for a specific use (such as, creating and installing software to process images). You may only use the operating system and associated software on the unit for that use.

You may use other programs with the operating system as long as the other programs:

- Directly support the manufacturer's specific use for the device, or
- Provide system utilities, resource management, or anti-virus or similar protection.

Software that provides consumer or business tasks or processes might not run on the device. This includes email, word processing, spreadsheet, database, scheduling, and personal finance software. The device can use Remote Desktop Services to access such software running on a server.

If you acquired the operating system and associated software on the unit, or on a disc or other media, a genuine Certificate of Authenticity label with a genuine copy of the software identifies licensed software. To be valid, this label must be affixed to the device or included on or in Zebra's software packaging. If you receive the label separately, it is not valid. You should keep the label on the device or packaging to prove that you are licensed to use the operating system and associated software.

The Microsoft operating system and associated software was designed for systems that do not require fail-safe performance. You may not use the Microsoft operating system and associated software in any device or system in which a malfunction of the software would result in foreseeable risk of injury or death to any person. This includes operation of nuclear facilities, aircraft navigation or communication systems, and air traffic control.

Linux

If you have a Linux SKU, your Zebra XV7 is pre-installed with a custom version of Linux (MIOS).

Operating, Mounting, and Installing Devices on the Zebra 4Sight XV7 Unit

This section provides instructions on how to get started with your Zebra 4Sight XV7.

Operating Zebra 4Sight XV7 for the First Time

Perform the following steps to operate Zebra 4Sight XV7 for the first time:

1. Mount the unit to your equipment so that it is not prone to being knocked off of its surface. For information see the [Zebra 4Sight XV7 mounting](#) section.
2. Connect your display device, keyboard, and mouse to the unit.

Depending on which power supply you are using, you will need to connect the 4Sight XV7 to either the AC or DC power supply. For information on how to connect your unit to power, see [Powering the Zebra 4Sight XV7 unit](#). Once the power supply and external devices are connected turn the unit on using the power switch on the front panel.

3. Once the unit boots, use the presented drop-down menu to select your language. Once you have selected the language, you cannot change your selection (you will have to reinstall the operating system to change the language).



NOTE: Zebra 4Sight XV7 assumes that your keyboard language is the same as the language you selected.

4. Verify that your connected devices are operating correctly.
5. Once your devices are operational, you can power down the unit to connect devices to the motherboard. For information on adding hardware to the Zebra 4Sight XV7 motherboard, see [Installing Full-Height, Three-Quarter Length PCIe Boards](#).
6. Connect any required peripheral devices.

Zebra 4Sight XV7 Mounting

The Zebra 4Sight XV7 unit comes with two external mounting brackets that can be attached to the unit. These brackets are used to attach the unit to shelves or other static parts of your production environment. Use these brackets so that the Zebra 4Sight XV7 unit is not prone to being knocked off of its surface.

To attach the mounting brackets, perform the following:

1. Decide how to attach both mounting brackets. The mounting brackets can be attached to the bottom or sides of the unit.

Figure 2 Zebra 4Sight XV7 mounting holes

Zebra 4Sight XV7 side mounting

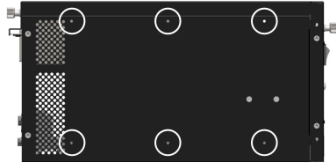

Zebra 4Sight XV7 bottom mounting



2. Align the three holes on each bracket with the mounting holes on the Zebra 4Sight XV7 unit. Use the screws in the mounting bracket bag to attach the mounting brackets to the Zebra 4Sight XV7 unit.

Attaching brackets to the bottom

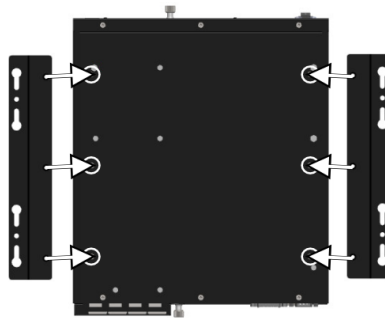

Attaching brackets to the side

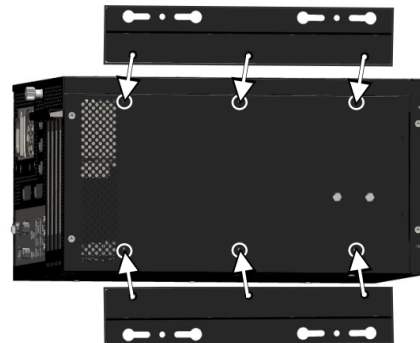

3. Fasten the mounting brackets to your equipment using the key holes on the brackets. Use fasteners of appropriate size and length to mount securely. Ensure that Zebra 4Sight XV7 is mounted to equipment that is sturdy and durable (for example, metallic equipment).

Powering the Zebra 4Sight XV7 Unit

To power your unit, you can either use an AC or DC power supply, depending on the Zebra 4Sight XV7.

Powering Using AC Power Supply

To power a Zebra 4Sight XV7 unit that comes with an installed AC power supply, connect the female end of the power cable to the AC power connector found on the back of your Zebra 4Sight XV7 unit and connect the male end of the power cable to your AC source. The AC power connector port on the back of your unit is shown below:

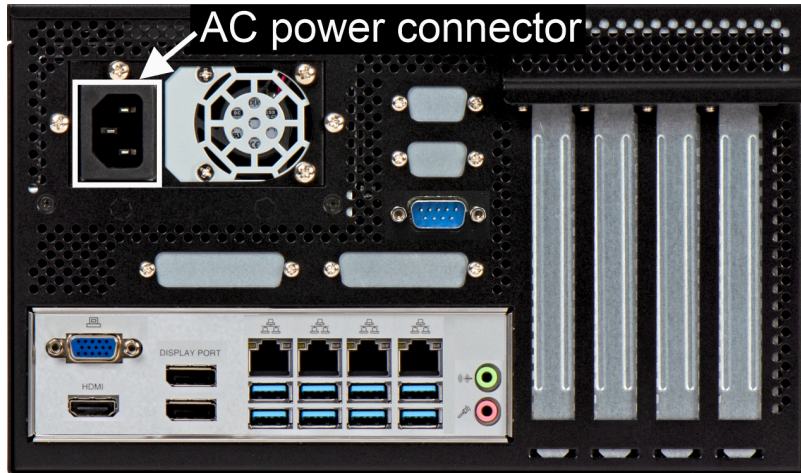

IMPORTANT: When connecting your Zebra 4SightXV7 to AC power, ensure that you are connecting your power cable to a power source that provides an earthing connection.

Powering Using DC Power Supply

To power a Zebra 4Sight XV7 unit that comes with an installed DC power supply, connect one cable to each of the 0V, 24V, and ground connectors found on the back of your Zebra 4Sight XV7 unit.



Each cable will need a crimped ring terminal on the end that connects to the back of the Zebra 4Sight XV7 unit. Once the ring terminals are secured to the cables, slide the cable terminals onto the 24 V and 0 V connectors, and use a Philips screwdriver to tighten the cables to the power supply connectors. The last connector is the ground connector and the cable terminal must be secured with a nut instead of a Philips screw.



NOTE: When connecting your Zebra 4Sight XV7 to DC power, ensure that the selected power supply, wire gauge, and length of cable meet the requirement of your setup. You must also account for any voltage drop that might occur when connecting your power supply. The power supply equipment shall be supplied by an Approved/Listed/Certified vendor and be isolated from the Mains by Reinforced Insulation. For information on the requirements to run the XV7 power supply, see the [Electrical Specifications](#) section.

Once the DC power cables are secured to the 4Sight XV7 power connector at the back of the unit, connect the other ends of the cables to the DC power source that you are using.



IMPORTANT: The DC source shall have a 40A all-pole circuit breaker available at the building DC power source.

Turning Off the Zebra 4Sight XV7 Unit

To turn off the Zebra 4Sight XV7 unit, flip the power switch to off. You can also shut down the unit by shutting down Windows with the Shut Down command.

Rebooting the Unit

When the unit is on, you can reboot the unit by pressing the Control+Alt+Delete on your keyboard simultaneously, or you can select the **Restart** option from the Windows Start menu.

If you need to enter the UEFI Setup utility, you must press Esc during power-on self-test (POST). You only have a few moments to press the F12 key before the boot-up process continues.



NOTE: On legacy computers, the UEFI was referred to as a BIOS. In some menu items, BIOS and UEFI are still used interchangeably.

Connecting Peripheral Devices

The following sections describe how to connect various devices to the external connectors of the Zebra 4Sight XV7 unit.



CAUTION: Be sure to turn off the power to the unit and all peripherals, as well as unplug the power from the unit before adding or removing devices.

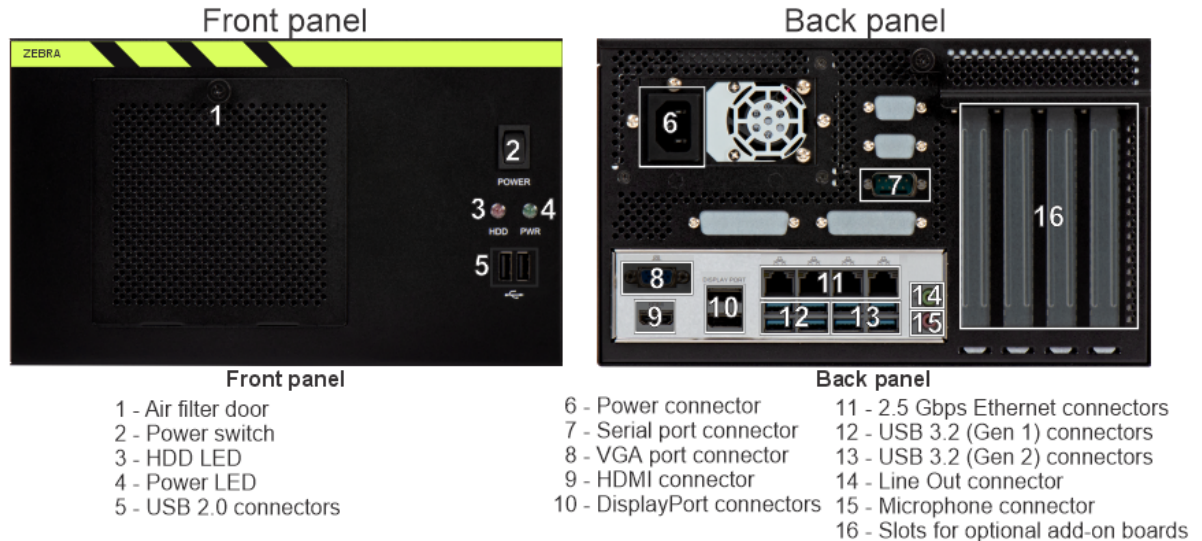

Zebra 4Sight XV7 has connectors on its front and back panel to connect to the following devices:

- Eight USB 3.2 connectors are available to connect to devices such as USB3 Vision cameras, a USB mouse, a keyboard, a printer, or a flash drive. Four USB connectors are Gen 1, which support speeds of up to 5 Gbps, and four connectors are Gen 2, which support speeds of up to 10Gbps. USB hubs can also be used to connect multiple USB devices to a USB connector.

- Four 2.5 Gigabit Ethernet connectors² are available to connect to your enterprise network and possibly your industrial network or a GigE Vision camera.
- Four video output connectors to which you can connect up to four display devices:
 - One VGA connector, with support for resolutions up to 1920x1200 @ 60Hz. You can connect one high-resolution analog display device (such as an analog monitor or analog flat panel) to this connector.
 - One HDMI 2.0a connector, with support for resolutions up to 4096x2160 @ 24Hz. You can connect a high-resolution digital display device (such as a digital flat panel) to this connector.
 - Two DP connectors, with support for resolutions up to 4096x2304 @ 60Hz. You can connect a high-resolution digital display device (such as a digital flat panel) to this connector.
- Two 3.5 mm minijacks (TRS) used for audio output and input.

To connect additional cameras or other types of cameras, you can install a frame grabber in the unit. See [Installing Full-Height, Three-Quarter Length PCIe Boards](#).



NOTE: Be aware that you should secure the cables connected to the Zebra 4Sight XV7, especially in vibrating environments. To do so either use zip-ties or dedicated cable harnesses to organize your cables.

Status Indicators (LEDs)

There are a total of ten LEDs on the Zebra 4Sight XV7 unit.

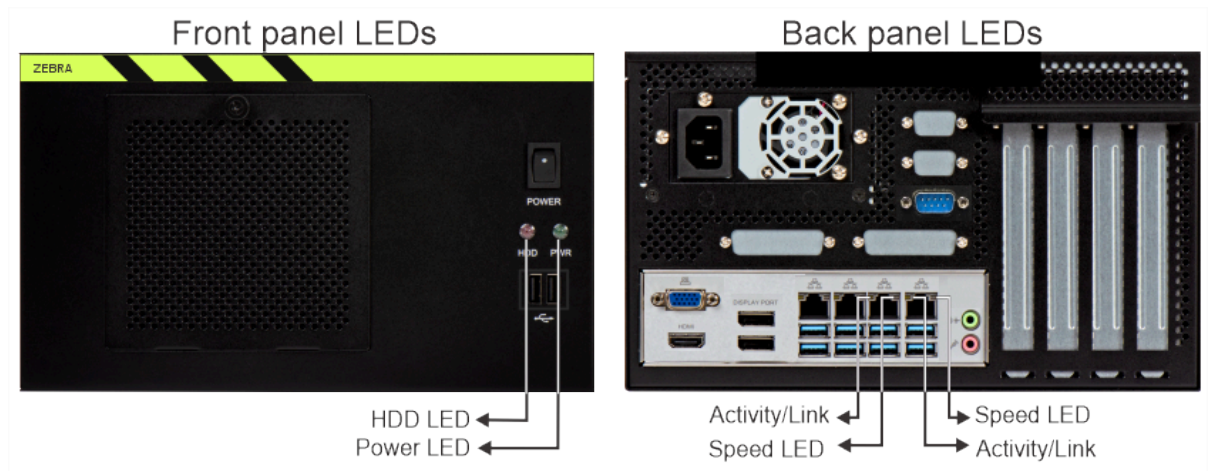

The following table describes the LEDs of each connector:

LED	Description
HDD LED	Turns green when any mass storage drive is active.
Power LED	Turns red when Zebra 4Sight XV7 is receiving power and turned on.

² Be aware that PoE is not supported.

LED	Description
Activity/Link LED	Turns on when connected to a network. Blinks whenever packets are being transmitted or received. Turns off when no network connection is present.
10/100/1000 LED	Turns off when one of the following conditions is true: - No network connection is present. - The unit is operating in 10 BaseT mode. If the unit is operating in 10 BaseT mode, the Activity/Link LED will be solid or blinking.

Networking Connections

You can connect Zebra 4Sight XV7 to your local area network (LAN), via 2.5 Gigabit Ethernet, or Fast Ethernet (100 BaseT). To do so, connect a network cable to one of the four Gigabit Ethernet connectors, located on the back panel of the chassis.

To make the connection, use an appropriate network cable. The required type of network cable depends on the type of connection:

Connection	Minimum category for network cable
Gigabit Ethernet	Category 5e (CAT5e)/ Category 6 (CAT6) cable
Fast Ethernet (100 Mbits/sec)	Twisted Pair Category 5 (UTP5) cable
10 Mbits/sec	UTP5/UTP3 cable

An RJ45 connector (shown below) must be attached to each end of the cable.

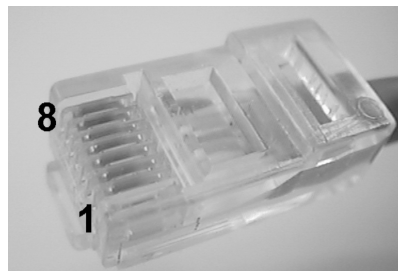

Each of the Gigabit Ethernet connectors on Zebra 4Sight XV7 has 2 LEDs to convey network activity and speed information. For information on how to read the LEDs, see the [Light emitting diodes \(LEDs\)](#) section.

Devices that can be Added to your Zebra 4Sight XV7 Motherboard

Zebra 4Sight XV7 is designed to accommodate selected hardware additions. The Zebra 4Sight XV7 motherboard has connectors to connect the following devices:

- Four SATA3 data connectors for connecting additional mass storage devices. For information on how to connect devices to the SATA3 data connectors, see the [Connecting a device to the SATA3 data connectors](#) section.

- Three M.2 sockets, one is E-Key and two are M-Key. One of the M-Key connector already has a 256 Gbyte NVMe SSD attached to it. For information on how to install a mini-board to one of the M.2 sockets, see the [Replacing the M.2 SSD attached to the M.2 socket](#) section.
- Four PCIe 4.0 connectors, two are PCIe x4, one is mechanically a PCIe x16 but electrically x8, and one is PCIe x16. These are used for connecting Zebra (or third party) full-height, three-quarter length add-on boards. For example, you can connect frame grabbers, digital I/O boards, and/or a Zebra board that supports hardware-assisted PROFINET communication (for example, Zebra Indio). For information on how to install add-on boards to the PCIe connectors, see the [Installing full-height, three-quarter length PCIe boards](#) section.
- Four 288-pin UDIMM memory slots. Two or four memory modules, with a total of 32 or 64 Gbytes of memory combined, come pre-installed in the slots, depending on what was ordered. For information on how to install UDIMM memory slots, see the [Installing or removing RAM](#) section.
- Four serial port headers. These 9-pin male connectors support the RS-232 standard and can be used with a custom adapter bracket that has a standard D-subminiature 9-pin (DB-9) connector so it can be accessed from outside the chassis. One of these headers is already in use.

The following diagram provides a reference to motherboard connectors:

Zebra 4Sight XV 7 motherboard

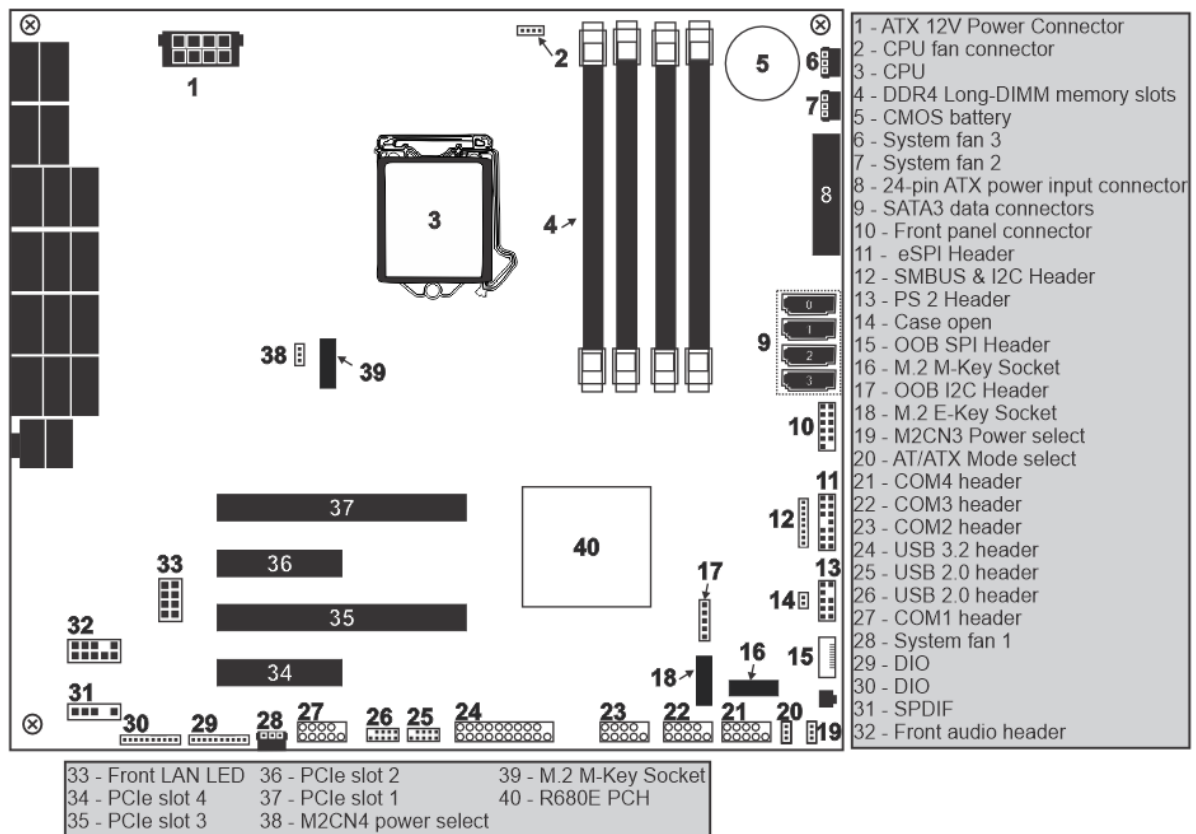

Removing the Zebra 4Sight XV7 Chassis Cover to Add Devices to your Motherboard

Follow the steps listed below to remove the chassis cover.

1. Power Zebra 4Sight XV7 down and unplug the Zebra 4Sight XV7 power cord.
2. Unscrew the knob on the Zebra 4Sight XV7 unit's back panel (see the following illustration).

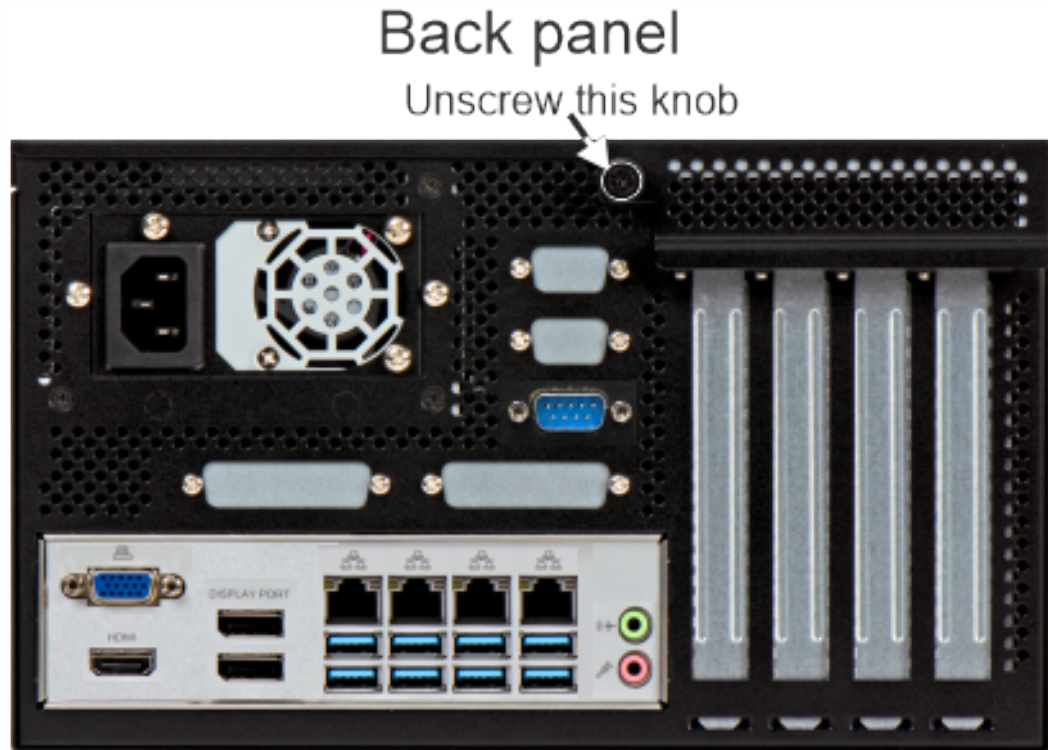

3. Slide the cover back and pull up to remove the lid.

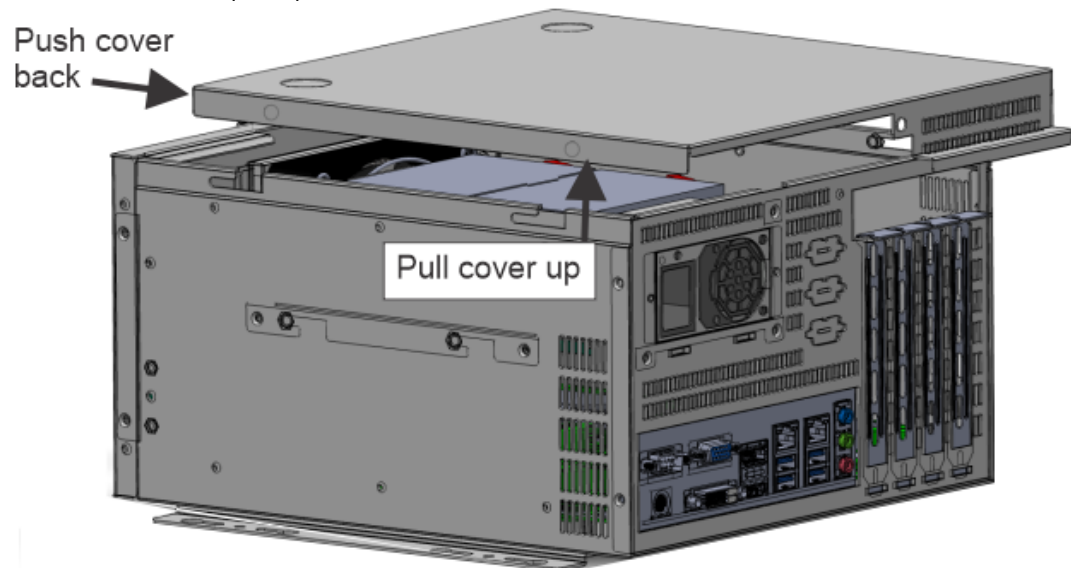

WARNING: Once you have removed the cover and exposed the motherboard, do not touch the heat sink or fans while the unit is running, or soon after the unit has been turned off; they might be very hot.

Installing Full-Height, Three-Quarter Length PCIe Boards

The Zebra 4Sight XV7 motherboard has the following PCIe connectors, which allow you to connect up to four Zebra (or third-party) full-height, three-quarter length PCIe boards to your Zebra 4Sight XV7:

Slot #	Description
1	PCIe 4.0 x16 ^a (only x8 if slot 3 is used)
2	PCIe 4.0 x4 (open-ended)
3	PCIe 4.0 x16 ^a (electrically x8)
4	PCIe 4.0 x4 (open-ended)

^a The first PCIe 4.0 x16 connector (slot 1) will operate at a x8 width when a board is present in the second PCIe 4.0 x16 connector (slot 3). The second PCIe 4.0 x16 connector (slot 3) is electrically wired as a PCIe x8 slot, so PCIe x16 boards will operate at a maximum of PCIe x8.



NOTE: Depending on the slot in which you install the board, it might not operate at full speed of the slot.

Zebra 4Sight XV7 supports PCIe boards with a single or a double bracket. You can install four boards with a single bracket, or two boards with a double bracket.



PCIe board
with a single bracket

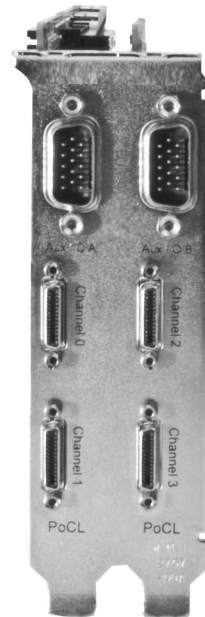

PCIe board
with a double bracket

To connect your PCIe board to the motherboard:

1. Remove the chassis cover. For instructions, see the [Removing the Zebra 4Sight XV7 chassis cover](#) section, earlier in this chapter.
2. Using a Phillips #2 screwdriver, remove the metal cover from the appropriate slot's opening on the back panel of your Zebra 4Sight XV7.

3. Ensure that the PCIe locks are open before installing or removing a board, and closed once the board is installed. Slide the PCIe lock to the right to open it and slide it to the left to close it.

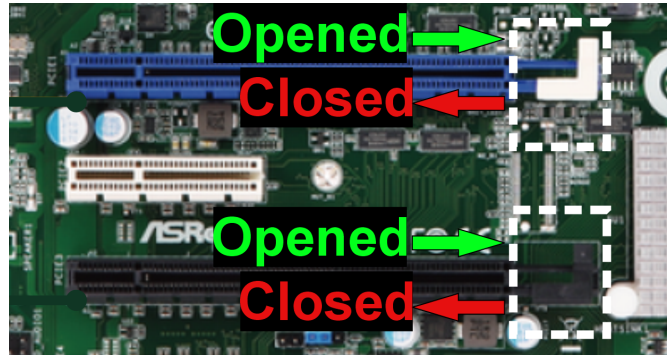

4. Position your PCIe board in the selected slot, as illustrated below.

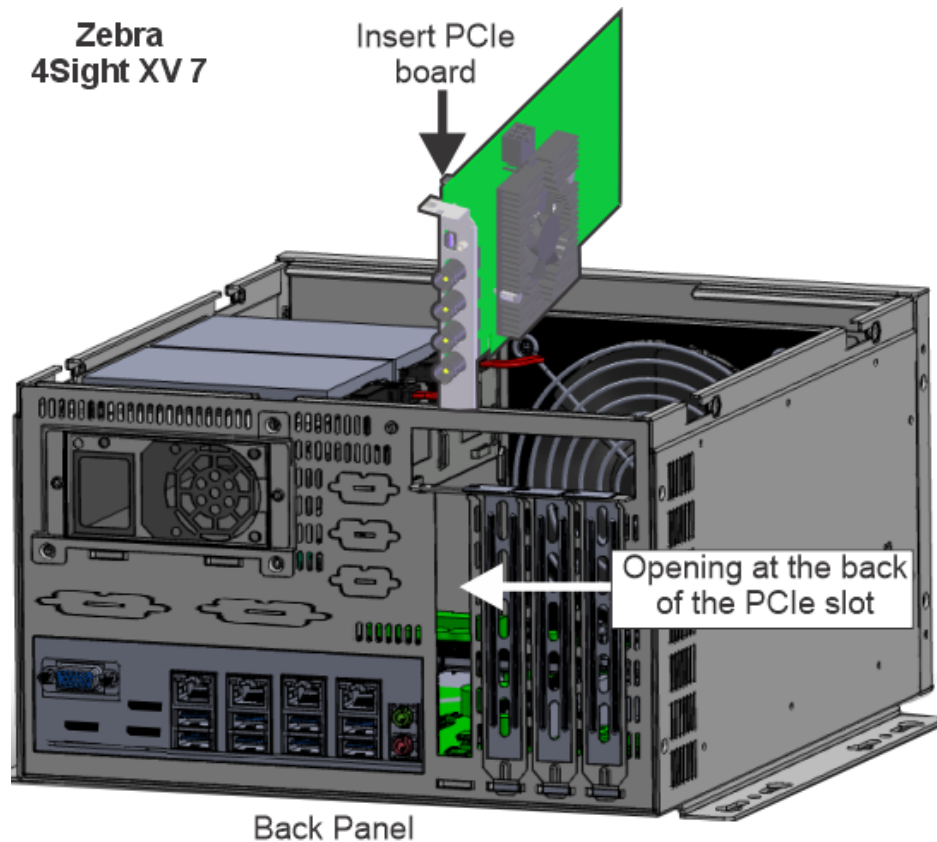

5. Press the board firmly but carefully straight down into the connector of the slot.
6. Close the PCIe locks (as illustrated above). Remember to reopen them if you need to uninstall the board(s).
7. If required by the add-on board, you can connect it to auxiliary power. There are two 15-pin SATA power connectors and two 6+2 pin PCIe power connectors available from the power supply for auxiliary

power. To access these power connectors, release the zip tie that holds all the cables coming from the power supply and connect the appropriate cable to your add-on board.

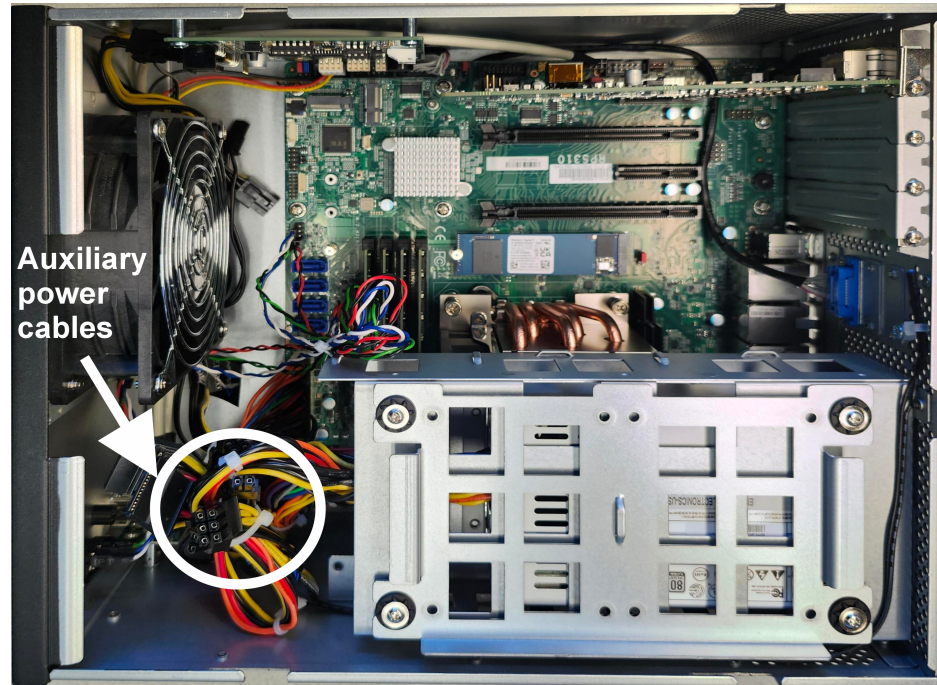

For information on the power provided by the power supply, see the [Electrical specifications](#) section.

Connecting a Device to the SATA3 Data Connectors

Besides the M.2-connected solid state drive (SSD) pre-installed in the unit, the Zebra 4Sight XV7 motherboard provides four 7-pin SATA3 data connectors for connecting additional storage devices, such as hard disk drives or solid-state drives (SSDs). If you chose to connect a device to one of these connectors, note that the unit only has space for a maximum of two SATA 2.5" HDD or SSD devices up to 9.5 mm thick. In addition, SATA3 connector 1 is shared with the M.2M-key socket; therefore, this connector is unusable when the M.2 SSD is installed.

Drive Assignments

When you connect a mass storage device to one of the 7-pin SATA3 data connectors, the operating system and UEFI⁴ identify it by the SATA connector (port) to which it is connected.



NOTE: SATA connector 1 is shared with the M.2 module and it is therefore unusable when an M.2 module is installed.

Replacing the M.2 SSD Attached to the M.2 Socket

An M.2 SSD comes pre-installed in the Zebra 4Sight XV7 unit's M.2 M-key socket. This SSD comes pre-loaded with your software and licensing. You should make a backup of this SSD before replacing it.

To replace the M.2 SSD in the Zebra 4Sight XV7 unit, perform the following:

⁴ On legacy computers, this was referred to as a BIOS, and in some menu items, BIOS and UEFI are still used interchangeably.

1. Unplug the power supply from your unit.
2. Remove the chassis cover.
3. Remove the screw that holds the M.2 SSD to the motherboard. The board will spring up at a 20 degree angle. Pull the board out at the same angle.
4. Slip the edge of the new M.2 SSD into the connector from which you removed the previous mass storage device. The connecting edge will fit neatly into the socket, leaving the board at a 20 degree angle from the motherboard.

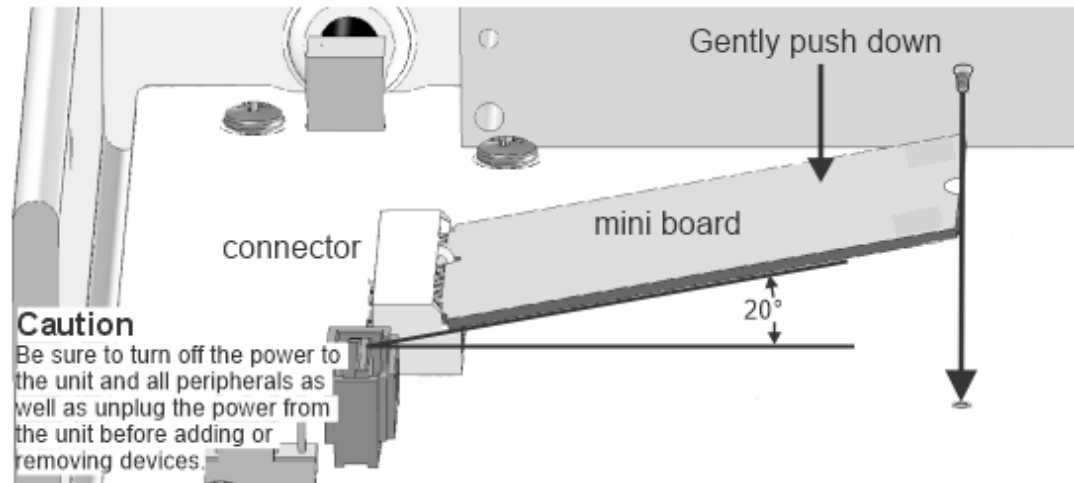

5. Press the mass storage device down and attach it to the motherboard with the same screw you removed in step 3.
6. Once the SSD is seated, reassemble the case.
7. Reconnect the power to your unit.



NOTE: Note that, the M.2 SSD will draw its power directly through the motherboard.

8. After your Zebra 4Sight XV7 boots, run the UEFI Setup program to verify that the SSD is identified correctly.

Installing or Removing RAM

The Zebra 4Sight XV7 motherboard features four 288-pin UDIMM slots in which you can install random access memory (RAM) modules. Each slot can support one DDR5 4800 Mbps SDRAM module up to 192 Gbytes in size. Contact Zebra for a list of supported modules.



NOTE: The motherboard supports dual-channel memory technology. This means that for optimal performance and reliability, when installing new memory modules, you should install the modules in pairs, starting with slots A0 and B0. Install identical memory modules in slots A0 and B0 and identical memory modules in slots A1 and B1. Mixing different models is not recommended.

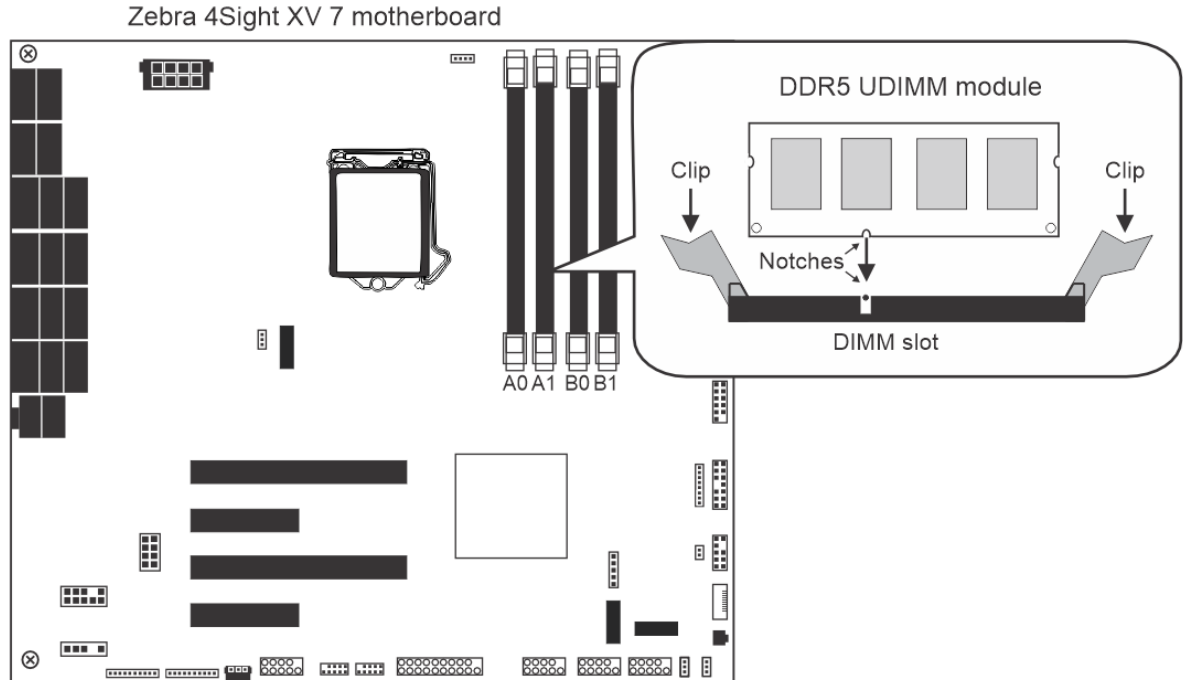

Installing memory

To install a memory module in the Zebra 4Sight XV7 unit:

1. Ensure that the clips at each end of the UDIMM slot are spread.
2. Position the module over the UDIMM slot, such that the notch along the module's bottom edge is aligned with the notch of the UDIMM slot. If installing additional memory modules, ensure they are the same model as the ones already installed.
3. Gently insert the bottom edge of the module into the slot.
4. Carefully close the two clips over the side notches of the module.

Removing memory

To remove a memory module from the Zebra 4Sight XV7 unit:

1. Spread the clips at each end of the UDIMM slot.
2. Lift the module out of the slot.

Memory settings

After installing memory in your Zebra 4Sight XV7, you must adjust the unit's new memory settings using the Aurora Imaging Configurator utility. See the Aurora Imaging Library User Guide for more information on using this utility.

Installing SATA Hard Drives

You can install up to two additional SATA hard drives, using the hard drive bracket found inside the unit. This bracket supports hard drives that are 2.5" wide and is mounted on top of the installed power supply.

Adding two hard drives can be useful in cases where you would like to use RAID configuration or need additional storage for your needs. When adding new hard drives to your system, ensure that you have them set up appropriately to work with your 4Sight XV7.

To install SATA hard drives onto the hard drive bracket, follow the steps below:

1. Power down your unit and ensure that it is unplugged from the main power supply.
2. Remove the chassis cover, as described in [Removing the Zebra 4Sight XV7 chassis cover](#).
3. Use a Phillips screwdriver to remove the four screws found on the top of the hard drive bracket, as outlined in the following image.

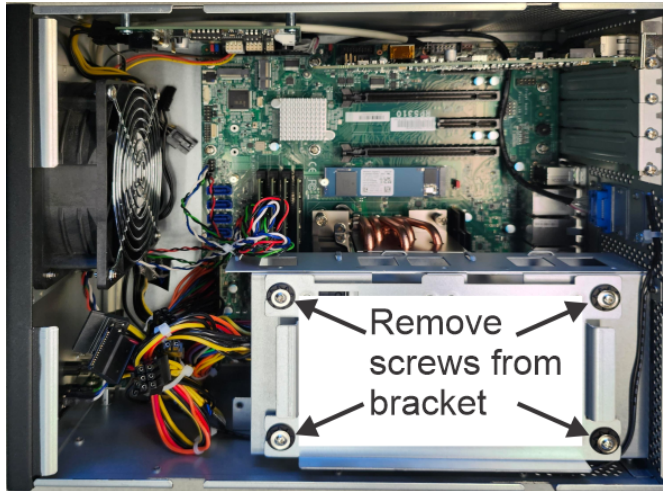

4. Using the screws provided in your accessory bag, you can attach up to two SATA hard drives. Ensure to line up the screw holes of the bracket with those found on the SATA hard drives and also orient your hard drive so that the power and data ports are facing away from the edge with a metal lip.

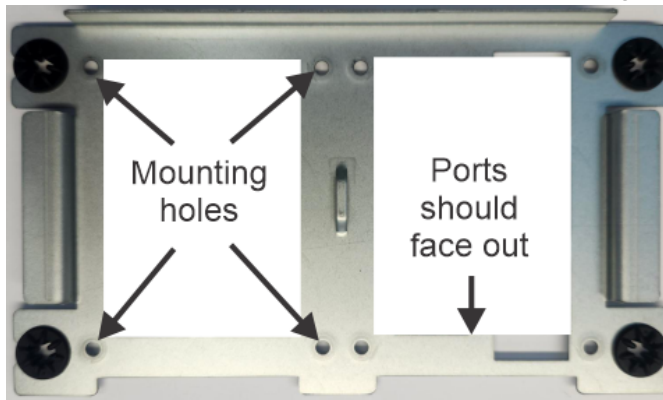

5. With the SATA hard drives mounted to the hard drive bracket, re-attach the bracket to the power supply bracket in the same way you took it off.
6. Connect the hard drives to the SATA power cables that come from the internal power supply.

7. Use the red SATA data cables provided in the accessory bag to connect the SATA hard drives to the SATA data ports on the motherboard.

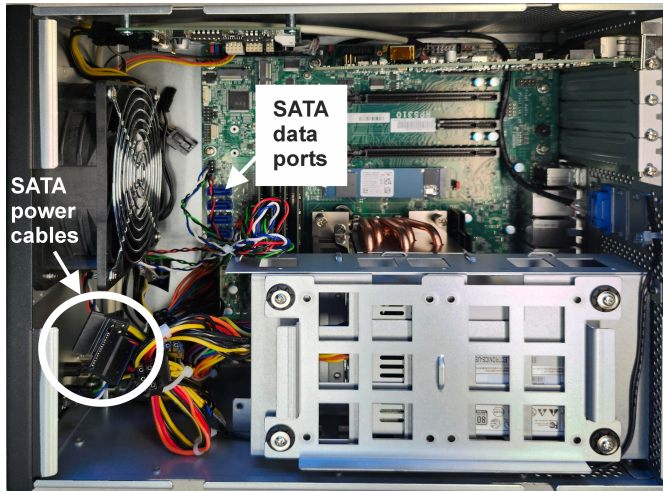

8. Close the chassis lid and turn the power on to your Zebra 4Sight XV7 unit.

Operation System Recovery and RAID Configuration

Zebra 4Sight XV7 with Windows comes with the Windows 11 IoT Enterprise operating system pre-installed. RAID configuration is also supported, which allows your system to have some backup redundancy. This chapter will discuss how to backup, restore, and recover your operating system, as well as how to configure your hard drives to use RAID.

Rescue Utility for System Backup and Recovery

To backup and restore Zebra 4Sight XV7 units the Zebra 4Sight XV7 Rescue utility and the Zebra 4Sight XV7 Windows IoT Enterprise configuration utility (OSConfig) come pre-installed; these utilities allow you to:

- Capture for deployment. Creates a master image of your Zebra 4Sight XV7 unit's operating system partition so that you can deploy the unit's operating system, applications, and user settings, to multiple Zebra 4Sight XV7 units. The capture process creates a rescue USB key with a capture-for-deployment backup .wim file. When you deploy the image, Out-Of-Box-Experience customization steps are also performed, which assign a new unique ID to the new unit.
- OS backup. Creates a backup image of your Zebra 4Sight XV7 unit's operating system partition and saves it to a USB key or specified drive. This process makes a backup (.wim) file similar to the capture-for-deployment backup, except it retains the unit's ID. This backup is only useful to restore the same unit from which the original backup was made, because it will also restore the unit's unique ID. When creating this type of backup, you have the option to simply save the backup file, or to create a rescue USB key (that is, to also configure the key with other files necessary for installing the backup image).
- Restore. Reverts Zebra 4Sight XV7 to its factory default settings, restores an OS backup, or restores a capture-for-deployment backup.



NOTE: The default mass storage device shipped with your Zebra 4Sight XV7 (M.2 SSD) has 4 partitions. The partitions are labeled as follows:

- RECOVERY. This partition is not assigned a drive letter.
- OS. This partition is assigned to the C: drive.
- SYSTEM. This partition is not assigned a drive letter.
- MSR. This partition is not assigned a drive letter.

This chapter only deals with the RECOVERY and OS partitions.

The RECOVERY partition houses the Zebra 4Sight XV7 Rescue utility and factory image, and does not get reformatted if you restore an OS backup .wim file from the Zebra Rescue utility console. However, if you use a rescue USB key with a capture-for-deployment backup .wim file (W11XV7.wim), then both the RECOVERY and SYSTEM partitions are reformatted and restored to their original factory-configured state provided by Zebra.

To perform any of the backup, capture, or restore tasks, you must access your Zebra 4Sight XV7 directly since remote desktop is not available in the recovery environment. To access the unit directly, connect a display device, keyboard, and mouse to your Zebra 4Sight XV7. For information, see the [Connecting peripheral devices](#) section.

For the latest information on backup, capture, and restore features, see the OSreleasenotes.txt file, found on the C: drive of your Zebra 4Sight XV7.

Configuration Utility Interface

To launch the configuration utility, open the run dialog by holding the Windows key + R. Type OSConfig.exe in the run dialog and press enter to launch the utility. Be aware that the configuration utility only runs with administrator privileges. Once the configuration utility is open, the interface will display a number of tabs that are used to confirm various settings and information. The tabs that are available in the configuration utility are listed below:

- **Global settings:** This tab displays essential information such as software version #, Windows version #, Aurora Imaging library version #, Zebra production version, Zebra BIOS version, Windows product ID, computer name, IP address, Windows defender status, Window update status, Mitigate protection status, and Automatic popup status.
- **Write Filter:** This tab provides options for the Unified Write Filter (UWF). After making your selection to change the status of the UWF, the unit must be rebooted for the changes to apply. When this feature is enabled, all writes directed to disk C: are redirected to RAM, the recycling bin is turned off, and the paging file is disabled. When the UWF is enabled, saving large files on your hard drive may overflow the UWF RAM overlay, which is why it is advised to create an extra partition for holding large files to avoid possible RAM overflow when UWF is enabled. If the overlay gets filled to its maximum capacity, the system will display an error (low memory) and the system will restart. To see which folders are not protected by the UWF, refer to the OSreleasenotes.txt file.
- **Capture OS:** This tab provides the option to backup the operating system. This is useful for creating a general backup, or a backup with specific customization already applied to your unit.
- **Languages:** This tab provides option to add or remove additional display languages.
- **SSD:** This tab provides options about the wear on your SSD drive. In this tab you can see the % of wear on your SSD drive and enable statistics to be logged about your drive on a daily basis.
- **EULA:** This tab displays the Microsoft Software License Terms and the Zebra Software License Agreement.
- **GigE Vision:** This tab provides options to configure and optimize the ports that you use to connect to your GigE Vision device.
- **Others:** This tab provides options to create a factory restore USB key. There are also options to change settings such as time zone, date, time. The Recommended actions window is available in this tab as well.

Microsoft Windows Out-Of-Box-Experience (OOBE)

When you start your Zebra 4Sight XV7 for the first time, Microsoft Windows performs its Out-Of-Box-Experience (OOBE) customization steps. The OOBE automatically performs initial customizations (such as setting the date and time), creates a default user and password, as well as generating a unique ID for your Zebra 4Sight XV7.

The following are some default settings set during the OOBE:

- User account: ZUser

- Password: Zebra
- Machine name: XV7AABBCC (AABBCC represent the last 6 digits of the MAC address)
- Auto logon is disabled
- The firewall is enabled with an exclusion for Remote Control
- File and Printer Sharing are enabled and already configured
- Timezone set for UTC with Daylight saving time disabled
- Remote Desktop feature access is enable

At the end of your OOBE, a Recommended actions window pops up and prompts you to set your time zone. After you have set your time zone accordingly, ensure that User Account Control (UAC) is off, and optionally choose to create a restore USB. To find the Recommended actions window after completing the OOBE, open the OSConfig utility and go to the Others tab. For information on the OOBE default settings, see the OSreleasenotes.txt file on your Zebra 4Sight XV7 unit's C: drive.

Capturing the Zebra 4Sight XV7 Operating System Partition for Deployment

You can capture an image of your Zebra 4Sight XV7's operating system partition (the operating system, application, and some settings) and then deploy it on multiple Zebra 4Sight XV7 units. The capture-for-deployment process will save the image to a capture-for-deployment backup .wim file, while also creating a rescue USB key so that you can deploy the capture to other Zebra 4Sight XV7 units. The capture-for-deployment backup .wim file does not contain the user settings and unique ID of the original unit. When you deploy the capture to the target units and reboot them, Microsoft Windows OOBE will assign them their own unique ID and allow you to configure their user settings.

To capture an image of your Zebra 4Sight XV7 unit's operating system partition, you must access your Zebra 4Sight XV7 directly; you cannot perform this task remotely. To access the unit directly, connect a display device, keyboard, and mouse to your Zebra 4Sight XV7. For information, see the [Connecting peripheral devices](#) section.

To make a capture-for-deployment backup of your Zebra 4Sight XV7, perform the following steps directly on your Zebra 4Sight XV7:

1. Log into the default local admin account (ZUser) and from the Windows Start menu, launch the OSConfig utility. Disable the Unified Write Filter (UWF) (if it is on), so that you can write to the drive. This option is found on the Write Filter tab of the OSConfig dialog.
2. Configure your Zebra 4Sight XV7 unit to your required specifications and ensure that you do not need to make any more changes.
3. Open the OSConfig utility from the Windows Start menu and select the **Capture OS** tab. In this tab, the **Click on the Reboot and launch Capture tool to create USB for deploy** option is grayed out, and to enable this option you must first click on the **Read this first** link.
4. Click on the **Reboot and launch Capture tool to create USB for deploy** option. Your Zebra 4Sight XV7 will reboot in audit mode (administrative mode).
5. When the reboot process completes, the System preparation tool (Sysprep) dialog opens to reseal the image. Once this is complete, the system will reboot to the System Recovery Options page.
6. When the reboot process completes, a list of possible options are displayed. Click on the Troubleshoot option and then on the Zebra Rescue Utility option.

7. When the Zebra Rescue Utility dialog opens, you must read the license agreement. When done, click on the I agree button to accept the license agreement.
8. The next page is presented, with an option already selected: **Capture the OS for deployment**; leave this option as is. Below this, you can specify the location of your USB key. Ensure your USB key has a minimum of 16 Gbytes. If you do not already have your USB key connected, you can do so now. Once you have selected the location of the USB key, you can press OK and the process will begin.



WARNING: This will reformat your USB key and all data will be erased.

The Zebra 4Sight XV7 Rescue utility configures the USB key to be a rescue USB key with all the necessary settings to restore your capture-for-deployment backup .wim file onto other Zebra 4Sight XV7 units.

9. When the process completes, a message dialog opens, explaining what was done. Click on the OK button to perform a shut down and reboot of Windows 11 IoT Enterprise.

To use the configured USB key to restore the operating system partition of your Zebra 4Sight XV7, or to configure another Zebra 4Sight XV7, see the [Restore Windows 11 IoT Enterprise](#) section.

OS Backup of Zebra 4Sight XV7 Windows 11 IoT Enterprise

You can create an OS backup .wim file of your Zebra 4Sight XV7 unit's operating system partition and save the file to a specified location. It is useful to do this procedure if you need to save any changes made to the specific Zebra 4Sight XV7 unit. Note that the OS backup process will copy the unique ID of the unit. This ID will be applied to any Zebra 4Sight XV7 that is restored with this backup .wim file; therefore, an OS backup should only be applied to the same unit from which it was taken. If two units with the same unique ID are running on the same network, there will be network conflicts. Be aware of this limitation when performing an OS backup.

To perform an OS backup, you must access your Zebra 4Sight XV7 directly; you cannot perform this task remotely. To access the unit directly, connect a display device, keyboard, and mouse to your Zebra 4Sight XV7. For information, see the [Connecting peripheral devices](#) section.

To backup your operating system partition, perform the following directly from your Zebra 4Sight XV7:

1. Save all your work and close all running applications.
2. From the Windows Start menu, launch the OSConfig utility.
3. Go to the **Write Filter** tab. If the Unified Write Filter (UWF) option is enabled, disable it.
4. Click on the **Capture OS** tab.
5. On the Capture OS tab, click on the **Reboot and launch backup tool** button that is found in the Backup for this unit area. Your Zebra 4Sight XV7 will reboot.
6. When the reboot process completes, it will display a screen asking you to choose an option. Click on the **Troubleshoot** option, and then on the **Zebra ResQDisk Utility** option.
7. When the Zebra ResQDisk Utility dialog opens, you must read the license agreement. When done, click on the **I agree** button to accept the license agreement.
8. The next page is presented with an option already selected: Backup the OS for this unit; leave this option as is. Below this, you can specify the location of your USB key. If you do not already have your USB key connected, you can do so now. It is not recommended to save the backup in the current operating system partition, or to a virtual drive. It is recommended to save to a USB key with at least 16 Gbytes free. Once you have selected the location of the USB key, click on **OK** and the Zebra ResQDisk utility will copy the information to the destination specified.

9. When the process completes, a message dialog will open, explaining what was done. Click on the **OK** button.
10. After the reboot, if UWF was enabled before you started the OS backup process, launch the OSConfig utility from the Windows Start menu, and re-enable UWF.



NOTE: Note that to restore the OS backup without a working copy of the operating system on your Zebra 4Sight XV7, additional files are required. The OS backup .wim file can either be used with the Zebra ResQDisk utility, if the RECOVERY partition is not corrupt, or with a rescue USB key, if the RECOVERY partition is corrupt. To restore your Zebra 4Sight XV7 with the Zebra ResQDisk utility, see the [Restore Windows 11 IoT Enterprise](#) section. To create a rescue USB key, see the [Making a rescue USB key for Windows 11 IoT Enterprise](#) section.

Making a Rescue USB Key for Windows 11 IoT Enterprise

In the case that your Zebra 4Sight XV7 operating system partition becomes corrupt, the easiest way to restore your unit is to use a rescue USB key containing the Zebra ResQDisk utility and a backup of your operating system partition. This procedure requires a USB key with at least 16 Gbytes.

To create a rescue USB key, you must access your Zebra 4Sight XV7 directly; you cannot perform this task remotely. To access the unit directly, connect a display device, keyboard, and mouse to your Zebra 4Sight XV7. For information, see the [Connecting peripheral devices](#) section.

When creating a rescue USB key, you must already have a backup file that you want to use for the recovery. This could either be the Zebra default factory settings backup .wim file (W11Ex64XV7.wim) that comes in your recovery partition, or an OS backup file that you have created (W11XV7.wim) using the procedure in the OS backup of Zebra 4Sight XV7 Windows 11 IoT Enterprise section earlier in this chapter.

To create a rescue USB key of your operating system partition, perform the following:

1. From the Windows Start menu, select **Settings**. From the presented window, select **Update & Security** and then **Recovery**. Under Advanced Startup, select **Restart now**. This will restart your Zebra 4Sight XV7 and then display the Zebra ResQDisk utility.
2. When the reboot process completes, it will display a screen asking you to choose an option. Click on the **Troubleshoot** option, and then on the **Zebra ResQDisk Utility** option.



NOTE: If you don't have access to the Zebra ResQDisk utility, contact Zebra support.

3. When the Zebra ResQDisk Utility dialog opens, you must read the license agreement. When done, click on the I agree button to accept the license agreement.
4. In the following dialog, select **Create USB drive for factory restore**.
5. Insert a USB key into your USB drive. If using a backup file that you have previously made and stored on a USB key, you will need to insert a second USB key with that backup.
6. The Zebra ResQDisk utility will open. In the **Select OS image** field, select to use the factory image or browse to the location where your required OS backup .wim file is found and use that file. In the Select USB storage device location field, select the USB drive that will be reformatted to a bootable USB drive.



NOTE: Note that this will reformat your USB key and all its data will be erased.

7. Select **Go** and the process of making a bootable USB drive will begin. When this operation completes successfully, your rescue USB key can then be used to either deploy a capture-for-deployment backup, restore an OS backup, or recover the operating system of your Zebra 4Sight XV7 unit to factory settings, depending on the .wim file that you used to make the bootable USB.

Restore Windows 11 IoT Enterprise

You can restore the Windows 11 IoT Enterprise operating system partition of your Zebra 4Sight XV7 unit, using the Zebra ResQDisk utility with an OS backup .wim file or a capture-for-deployment backup .wim file.



WARNING: The restore operation will reformat and erase all data currently on the Zebra 4Sight XV7 storage drive (SSD). If you have two (or more) partitions on your Zebra 4Sight XV7 storage drive, or have external drives connected, select the correct drive or disconnect from all external hard drives to prevent data being erased by accident.



NOTE: The RECOVERY partition houses the Zebra ResQDisk utility and does not get reformatted if you restore an OS backup .wim file from the Zebra ResQDisk utility console. However, if you use a rescue USB key with a capture-for-deployment backup .wim file (W11XV7.wim), or restore to factory default settings file (W11Ex64XV7.wim), then both the RECOVERY and OS partitions are reformatted.

To perform any of the backup, capture, or restore tasks, you must access your Zebra 4Sight XV7 directly since remote desktop is not available in the recovery environment. To access the unit directly, connect a display device, keyboard, and mouse to your Zebra 4Sight XV7. For information, see the [Connecting peripheral devices](#) section.

To restore your Zebra 4Sight XV7 unit's operating system partition, perform the following:

1. From the Windows Start menu, select **Settings**. From the presented window, select **Update & Security** and then **Recovery**. Under **Advanced Startup**, select **Restart now**. This will restart your Zebra 4Sight XV7 and then display the Zebra ResQDisk utility.
2. When the reboot process completes, it will display a screen asking you to choose an option. Select **Zebra 4Sight XV7 - Restore OS**.
3. Select which .wim file (W11XV7.wim) to restore.



NOTE: Note that these files are created with the OS backup or capture-for-deployment backup options, described earlier in this chapter.

4. Follow all on-screen instructions.

RAID Configuration

RAID configuration allows your system to have built in redundancy to protect against defective sectors of your drive or read errors. This configuration does not protect against catastrophic failures (for example, fire or water). Depending on your requirements there are different RAID levels, which provide different ways for the data to be split across the two hard drives. Before you attempt to setup RAID configuration, ensure that you have two 2.5 SATA hard drives that are identical. Before you attempt to setup RAID configuration, ensure that you have two 2.5 SATA hard drives already installed in the unit. For information on how to install multiple hard drives, refer to [Installing or removing SATA hard drives](#).



NOTE: The two hard drives that you use for RAID configuration must be the same size and model.

To configure RAID on the 4Sight XV7 unit, follow the steps below:

1. Ensure two hard drives are mounted, powered, and connected to the inside of your chassis. For information on how to install multiple hard drives, refer to [Installing or removing SATA hard drives](#).

- Restart your unit and boot into the UEFI⁵ setting by pressing F12 at the boot screen.
- Navigate to the **Advanced** screen and select **Intel® Rapid Storage Technology**.

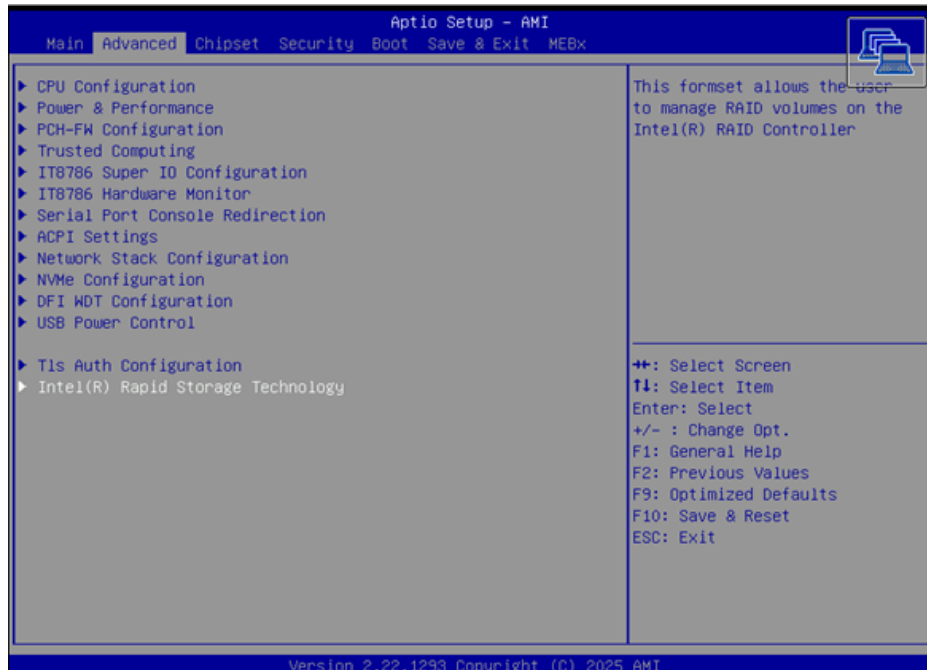

- On this screen select **Create RAID volume**.

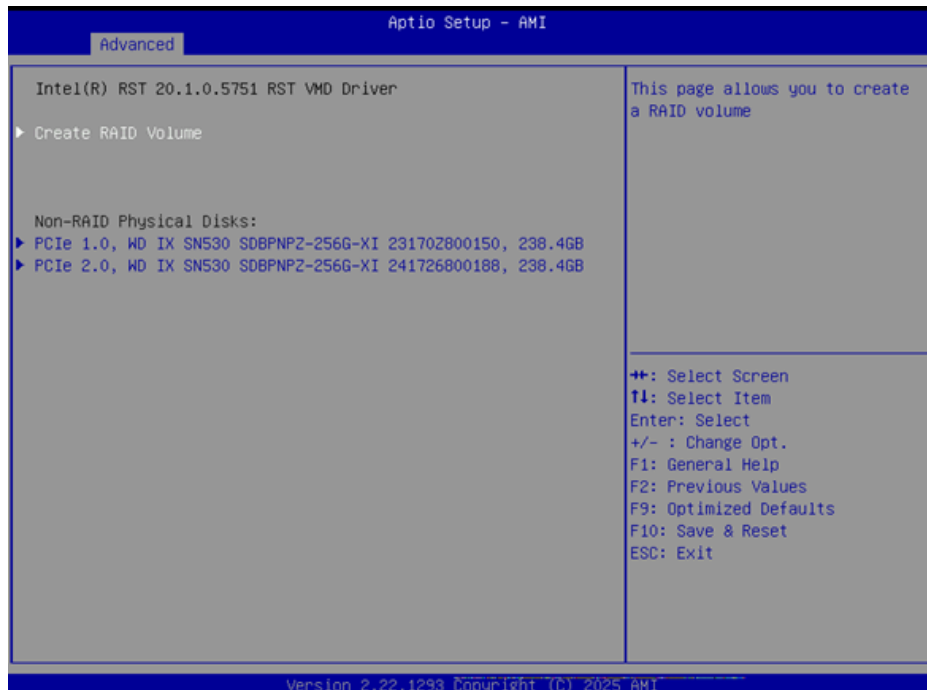

⁵ On legacy computers, the UEFI was referred to as a BIOS. In some menu items, BIOS and UEFI are still used interchangeably.

5. Enter a name for your RAID volume, select the RAID level, and select the hard drive to use to create the volume. Once this is done you can select **create volume** and the configuration will begin.



NOTE: RAID levels 0 and 1 are supported by the 4Sight XV7

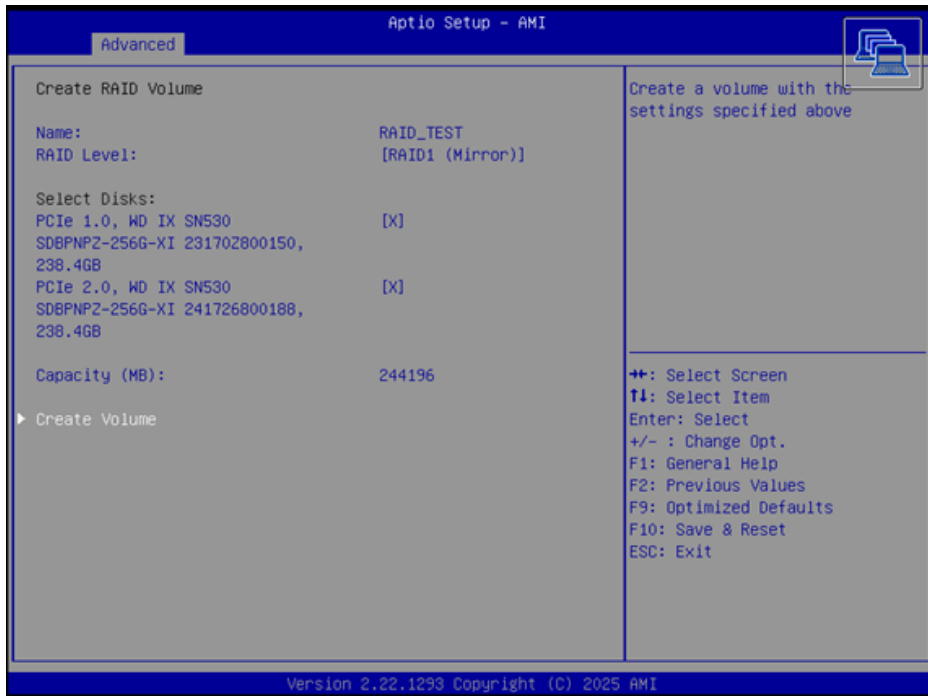

6. Once the configuration is complete, it will appear in the **Advanced** screen under the listed RAID volumes. Press F10 to Save the configuration and your unit will restart.

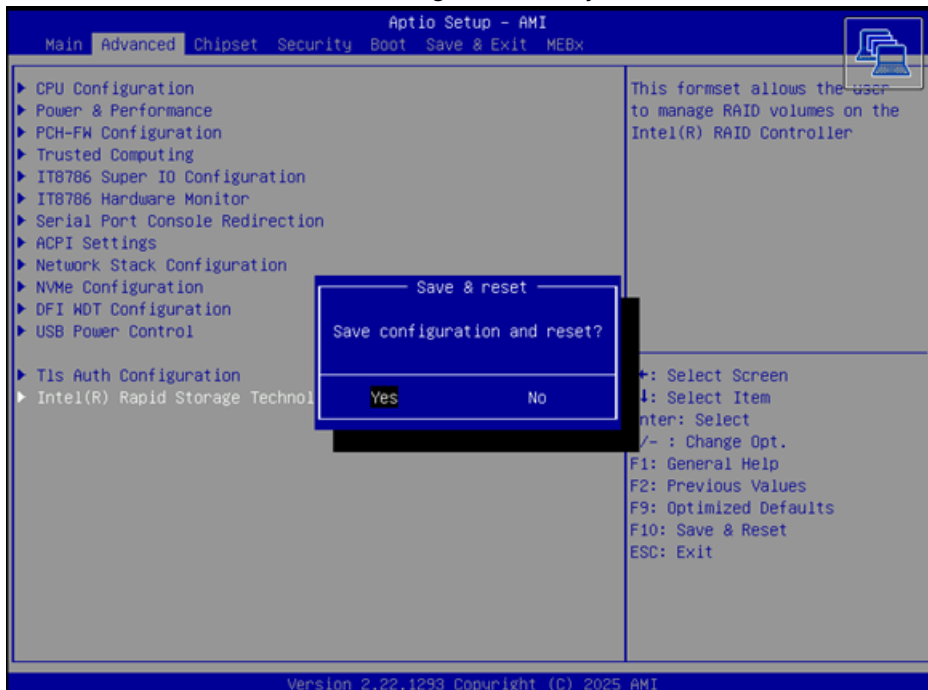

Cleaning the Air Filter

The Zebra 4Sight XV7 unit contains a polyurethane air filter. The air filter prevents dust and dirt from entering the unit. To ensure efficient cooling of the Zebra 4Sight XV7 unit, you must regularly clean the air filter as follows:

1. Before cleaning, turn off the Zebra 4Sight XV7 unit and unplug the power cord.
2. Using a household vacuum, turned on at a low setting, position the vacuum nozzle in front of the air vents on the front panel of Zebra 4Sight XV7. Excess dust and particles will be safely removed through the air vents.

Alternatively, the air filter can be cleaned and washed with water, but it must be dried completely before being reinstalled in the 4Sight XV7. To wash the air filter with water, you must remove it from the chassis, by following the steps below:

1. Unscrew the thumb screw holding the air filter door at the front of the unit.
2. Swing down the air filter door bracket and remove the air filter from the unit.

Technical Reference

This section summarizes the key features of the Zebra 4Sight XV7 unit. In addition, this appendix provides descriptions for external and internal connectors of the Zebra 4Sight XV7 unit.

Motherboard

- Micro-ATX based form factor.
- One of the following processors:
 - Intel i5-14501-E
 - Intel i7-14700
 - Intel i9-14900
- Intel Platform Controller Hub (PCH) 680E chipset.
- Supports up to four devices, which can be connected to the available video output connectors: HDMI, DisplayPort, and VGA. The video output connectors support the following maximum resolutions:

Connector	Maximum resolution
VGA	1920 x 1200 @ 60 Hz
HDMI version 2.0a	4096 x 2160 @ 24 Hz
DP	4096 x 2304 @ 60 Hz

- Four Gigabit Ethernet interfaces that use standard RJ-45 Ethernet connectors⁶. Three use an I226-V Gigabit Ethernet controller, and one uses a I226-LM controller. Each supports 2.5GbE connections.
- Ten USB interfaces. There are two USB 2.0 connectors on the front of the unit and eight USB 3.2 connectors on the back, four of which are Gen 2 and four are Gen 1. Inside the unit on the motherboard, there are two USB 2.0 headers⁷ and one USB 3.2 header, each of which support two USB ports per header.
- One serial port connector on the outside of the unit; you can connect a device through either the RS-232, RS-422, or RS-485 standard. There are also three additional RS-232 serial port headers available on the motherboard inside the unit.
- Support for stereo audio output, and a microphone.

⁶ PoE is not supported on either Ethernet connector.

⁷ The external 2.0 USB connectors are connected to one of the internal USB 2.0 headers.

- Four PCIe 4.0 slots:

Slot #	Description
1	PCIe 4.0 x16 ^a (only x8 if slot 3 is used)
2	PCIe 4.0 x4 (open-ended)
3	PCIe 4.0 x16 ^a (electrically x16)
4	PCIe 4.0 x4 (open-ended)

^a The first PCIe 4.0 x16 connector (slot 1) will operate at a x8 width when a board is present in the second PCIe 4.0 x16 connector (slot 3). The second PCIe 4.0 x16 connector (slot 3) is electrically wired as a PCIe x8 slot, so PCIe x16 boards will operate at a maximum of PCIe x8.

- Three M.2 sockets. One is E-Key with support for PCIe x1, CNVI, and USB 2.0 for wireless. Two are M-Key and the one closest to the CPU is used to connect the 256 Gbytes NVME SSD.
- Four 288-pin UDIMM slots supporting dual-memory channel DDR5-4400 MHz RAM (ECC/Non-ECC). Each slot supports a memory module up to 192 Gbytes in size.
- Four SATA3 data connectors. One SATA3 data connector is shared with the M.2 M-Key socket.

Memory

Zebra 4Sight XV7 supports UDIMM DDR5 SDRAM. Zebra 4Sight XV7 ships with either two or four 16-Gbyte DDR5 SDRAM modules that are non-ECC and run at up to 5600 Mbps.

Default Storage Drive

- M.2 NVME SSD.
- Storage capacity: 256 Gbytes.



NOTE: Drive specifications are subject to change without notice.

Fans

The fans, which are used to cool the unit, operate at speeds controlled by the on-board fan controller, based on the temperatures of the processor and the motherboard.



NOTE: When the unit is first turned on, or restarted, the fans will initially operate at their maximum speed.

Air Filter

The Zebra 4Sight XV7 unit contains a polyurethane air filter. The air filter will need to be cleaned on a regular basis. If you operate your Zebra 4Sight XV7 in a dusty environment, you might notice that the unit is overheating, or that the fan is running faster and noisier than usual. These are indicators that the filter needs to be cleaned. For information on how to clean it, see the [Cleaning the air filter and adding devices to Zebra 4Sight XV7](#) section.

Environmental Specifications

- Minimum/maximum ambient operating temperature: 0 to 45°C (32 to 113°F).
- Minimum/maximum storage temperature: -40 to 70°C (-40 to 158°F).
- Operating altitude: up to 2000 meters.

- Operating humidity:
 - For DC power supply: 20 to 80% (non-condensing).
 - For AC power supply: 20 to 85% (non-condensing).
- Storage humidity: 20 to 85% (non-condensing).
- Pollution degree 2 environment.
- Designed for indoor use only.

Electrical Specifications

The AC power supply has the following specifications. This only applies to the Zebra 4Sight XV7 SKUs that use AC power:

Specification	Value
Input current at min and max voltage	8A @ 100Vac to 4A @ 240Vac, 60- 50Hz
Output power	440W

The DC power supply has the following specifications. This only applies to the Zebra 4Sight XV7 SKUs that use DC power:

Specification	Value
Input current at min and max voltage	33A @ 18Vdc to 16A @ 36Vdc
Output power	336W

Warning

- In addition to the PSU power limits documented on the PSU and in the manual, the wires in the cable harness, used to bring power to motherboard components and computer peripherals, have a current rating that must be met at all times for each individual wire in the harness.
- The unit ships with a number of cables in the PSU harness already connected to the motherboard and peripherals. These cables should not be disconnected by the user.
- Do not use cable splitters or cable adapters that would allow exceeding the current rating of the harness.
- Only use the cable adapters in the accessory kit supplied with the unit.
- Before connecting power to user add-in board and peripherals, make sure the unit is off and the AC cord is disconnected.

Coin Cell Battery

A coin cell battery installed in the motherboard. This battery should not be removed and if you do need to replace it contact a Zebra technical support specialist.

- Used to maintain time and date settings of the unit's real-time clock.
- Battery voltage: 3 V.
- Diameter (max): 20 mm.
- Battery type: CR2032.

Dimensions and Illustrations

Zebra 4Sight XV7 has a rugged, heavy-duty steel chassis with mounting points that allow mounting the unit to other equipment or sturdy surfaces. The dimensions of the Zebra XV7 are: 33.43 L x 15.5 H x 26.2 W cm (13.16 in x 6.1 in x 10.32 in)

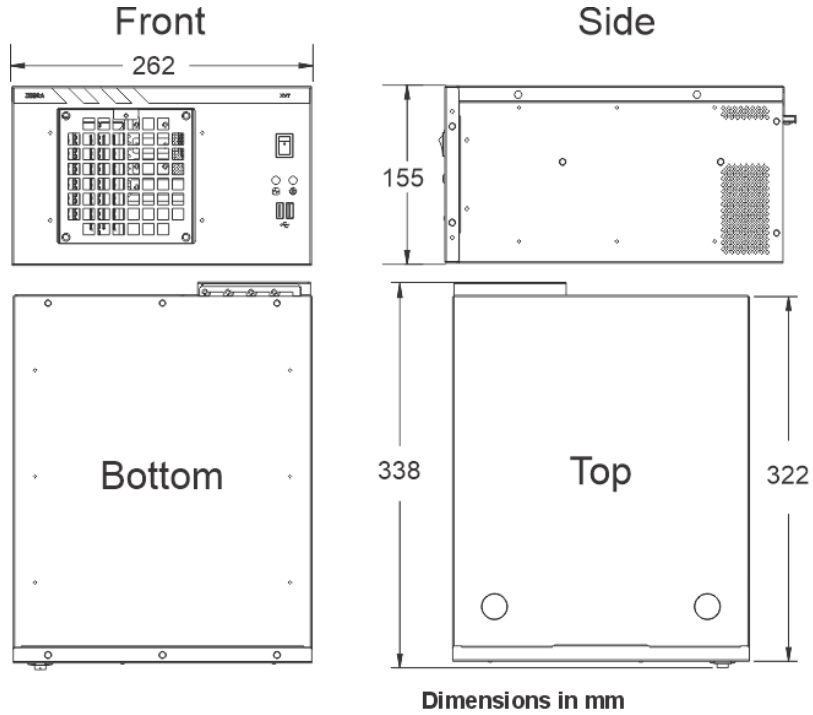

Status Indicators (LEDs)

There are a total of ten LEDs on the Zebra 4Sight XV7 unit.

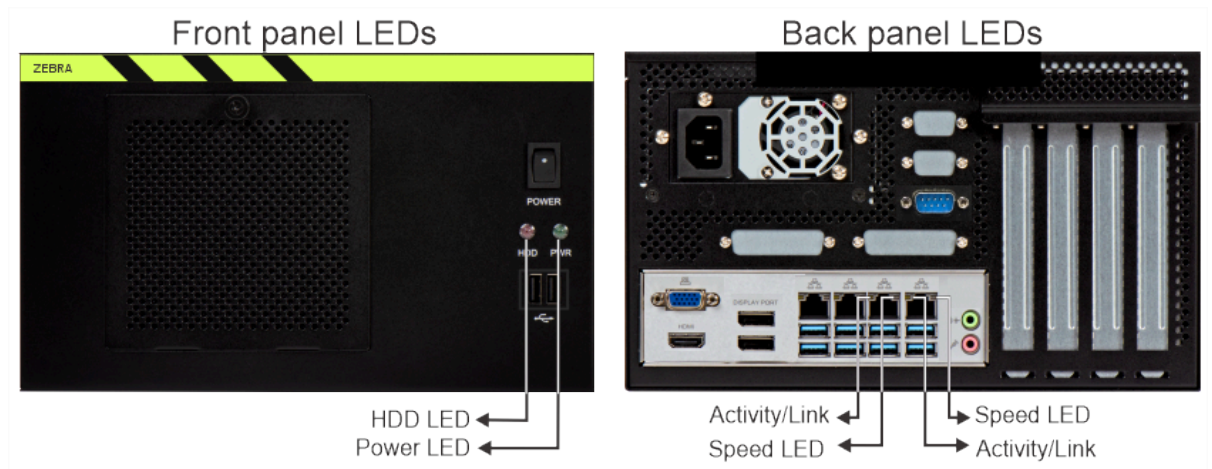

The following table describes the LEDs of each connector:

LED	Description
HDD LED	Turns green when any mass storage drive is active.
Power LED	Turns red when Zebra 4Sight XV7 is receiving power and turned on.
Activity/Link LED	Turns on when connected to a network. Blinks whenever packets are being transmitted or received. Turns off when no network connection is present.
10/100/1000 LED	Turns off when one of the following conditions is true: - No network connection is present. - The unit is operating in 10 BaseT mode. If the unit is operating in 10 BaseT mode, the Activity/Link LED will be solid or blinking.

Descriptions of External Connector

The Zebra 4Sight XV7 unit features the following external connectors:

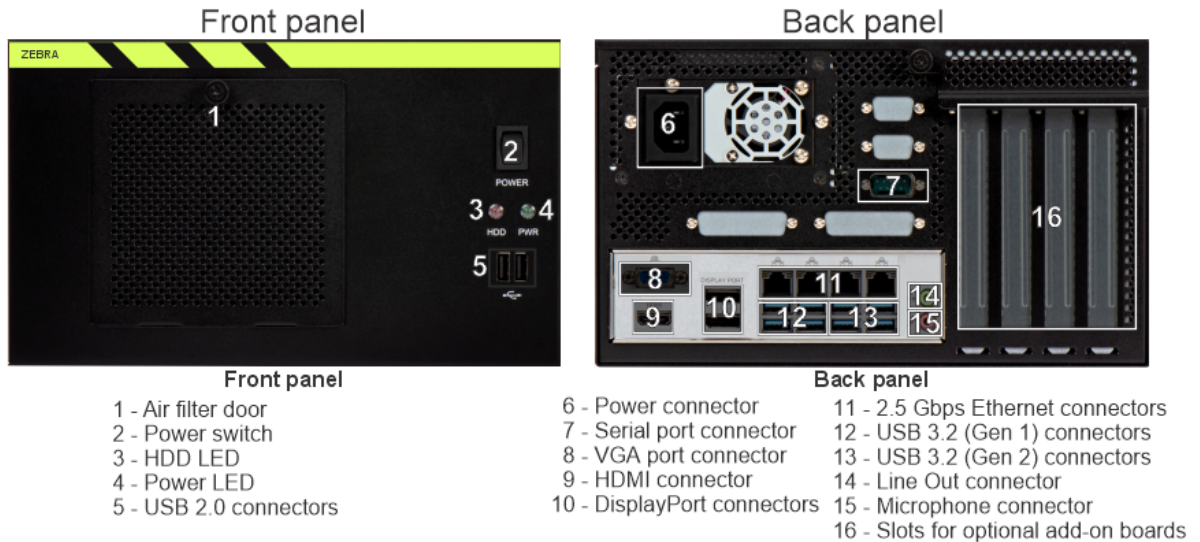

USB 2.0 Connectors

The 2 USB 2.0 connectors on the front panel are standard rectangular, Series “A”, 4-pin receptacles. The USB 2.0 interfaces run at 480 Mbps. The pinout of these standard connectors is described in the USB Specification v2.0 from the USB Implementers Forum.

- Operating voltage and maximum current: 5 V, 500 mA.
- Over-current protection: Yes.



USB 3.2 Connectors

The 8 USB 3.2 connectors on the back panel are standard rectangular, Series “A”, 9-pin receptacles, and are backwards compatible with USB 3.0/2.0/1.1. Four of the USB 3.2 connectors run at 5 Gbps (Gen 1) and four of the USB3.2 connectors run at 10Gbps (Gen 2). The pinout of these USB 3.2 connectors is described in the USB Specification v3.0 from the USB Implementers Forum.

- Operating voltage and maximum current: 5 V, 900 mA.
- Over-current protection: Yes.



Gigabit Ethernet Connectors

The 4 Gigabit Ethernet connectors are 8-pin, RJ45 connectors. The pinout of these connectors follows the 2.5 Gigabit Ethernet standard found in the IEEE 802.3-2002 standard.

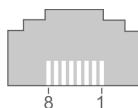

DP Connector

The DP connector is a 20-pin female connector used to connect a display device such as a monitor. This connector supports DisplayPort specification version 1.2. The pinout for this connector is standardized by the Video Electronics Standards Association.



NOTE: This port does not support DP++.

HDMI Connector

The HDMI connector is a 19-pin female connector used to connect a high definition display device such as a monitor. This connector supports HDMI version 2.0a. The pinout for this connector is standardized by the HDMI forum.

Analog Video Output (VGA) Connector

The analog video output (VGA) connector is a high-density D-subminiature 15-pin, (HD-15) female connector. The pinout is outlined in the following table.

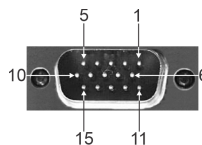

Pin	Signal	I/O	Description
1	Red	O	Red
2	Green	O	Green
3	Blue	O	Blue
4	NC	-	Not connected
5-8	GND	-	Ground
9	+5V	O	Power +5V; Includes an auto-resettable fuse. Maximum current:5V, 0.75A
10	GND	-	Ground
11	NC	-	Not connected
12	SDA	I/O	DDC serial data line
13	HSYNC	O	Horizontal synchronization
14	VSYNC	O	Vertical synchronization
15	SCL	I/O	DDC data clock line

Serial Port Connector (COM Port)

The serial port connector is a standard D-subminiature 9-pin (DB-9) male connector. Although the port is configured for the RS-232 standard by default, the configuration of the connector can be changed to accommodate either the RS-422 or RS-485 standard by adjusting the unit's UEFI setting; its pinout is outlined in the following table.



NOTE: COM2 is used for the external serial port connector that comes installed on your unit, which is what is reflected in the pinout table below.

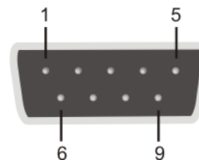

Pin	Hardware signal name	Signal
1	Modem Data Carrier detect	MDCD-
2	Modem Receive data	MSIN-
3	Modem Transmit data	MSO-
4	Modem Data terminal ready	MDTR-
5	Ground	GND
6	Modem Data set ready	MDSR-

Pin	Hardware signal name	Signal
7	Modem Request to send	MRTS-
8	Modem Clear to send	MCTS-
9	No power 5V/12V	MRI-
10	-	-

Audio Input, Audio Output, and Microphone Connectors

The audio input, audio output, and microphone connectors are 1/8" mini audio plugs. You can connect a stereo audio device to the audio input, audio output, or microphone connectors, respectively.

AC Power Connector

The Zebra 4Sight XV7 has an internal power supply. If you purchased the AC version of the 4Sight XV7 the power supply connector is a standard AC power connector, and the appropriate power cord is included with the Zebra 4Sight XV7 unit.



DC Power Connector

The Zebra 4Sight XV7 has an internal power supply. If you purchased the DC version of the 4Sight XV7 the power supply connectors are terminals found on the outside of the unit, which are connected by appropriate cables. For information on how to connect the DC power connector, see the [Powering using the DC power supply](#) section.

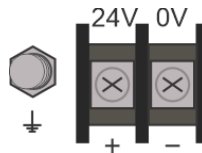

Descriptions of Internal Connectors

The Zebra 4Sight XV7 unit features the following internal connectors:

Zebra 4Sight XV 7 motherboard

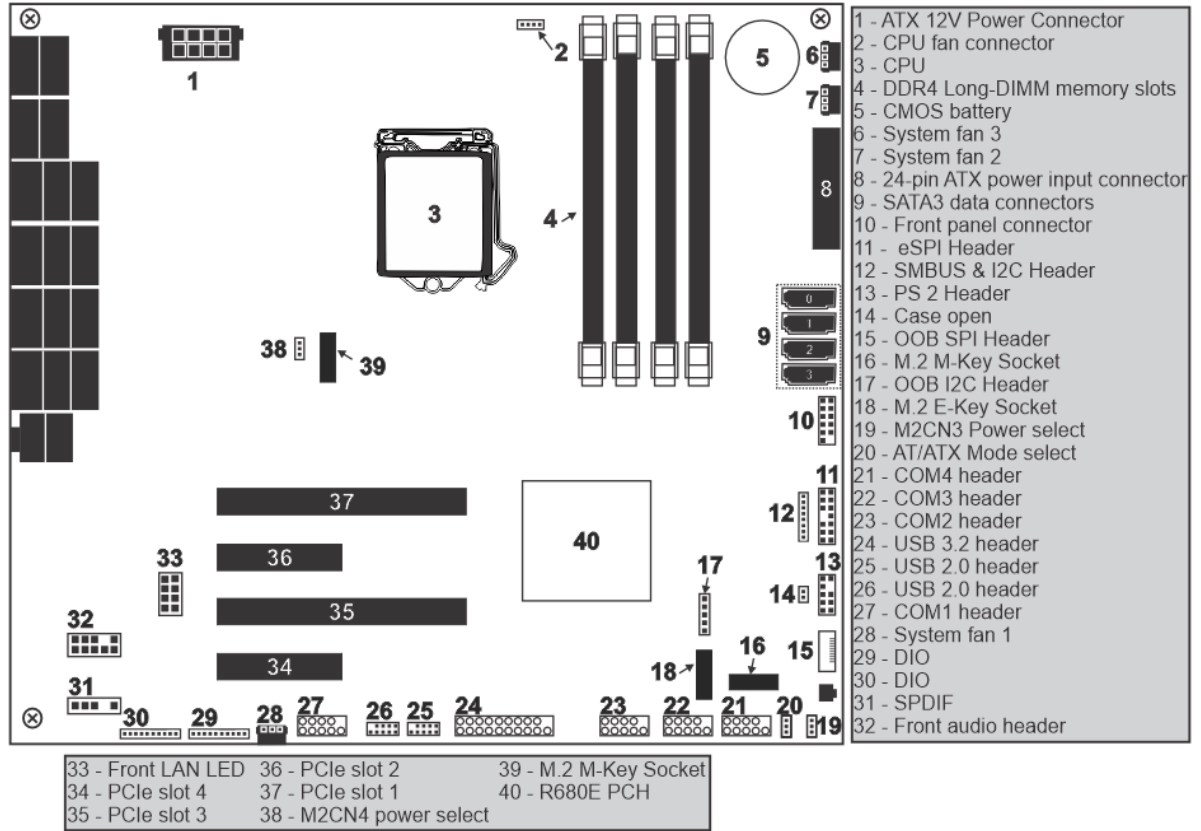

SATA3 Data Connectors for Mass Storage Devices

The four SATA3 data connectors are 7-pin, male connectors. They can be used for mass storage devices. The pinout for the SATA3 connectors is available at the website of the Serial ATA International Organization, <http://www.sata-io.org>.

Internal USB 2.0 Headers

The two USB 2.0 headers are 9-pin male connectors. Each USB 2.0 header supports two ports; you can use a custom adapter bracket with two USB 2.0 connectors to access these from the exterior of the unit.

Back of
Zebra 4Sight XV 7

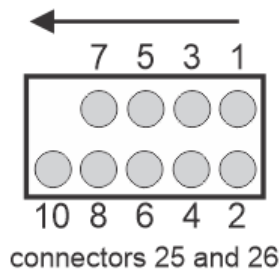

Pin	Signal
1	5V DU
2	5V DU
3	USB1N
4	USB2N
5	USB1P
6	USB2P
7	GND
8	GND
9	-
10	NC

Internal USB 3.2 Headers

The single USB 3.2 header is a 19-pin male connector. The USB 3.2 header supports two ports; you can use a custom adapter bracket with two USB 3.2 connectors to access these from the exterior of the unit. The USB 3.2 interface runs at 20 Gbps.

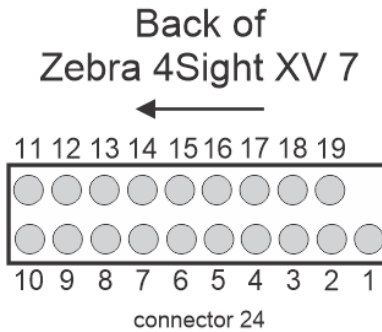

Pin	Signal
1	5V DU
2	USB3 RX1 DN
3	USB3 RX1 DP
4	GND
5	USB3 TX1 DN
6	USB3 TX1 DP
7	GND
8	USB2 1N
9	USB2 1P
10	NC

Pin	Signal
11	USB2 2P
12	USB2 2N
13	GND
14	USB3 TX2 DP
15	USB3 TX2 DN
16	GND
17	USB3 RX2 DP
18	USB3 RX2 DN
19	5V DU
20	-

Serial Port Headers

The three serial port headers are 9-pin male connectors. These connectors support RS-232/422/485 standards. You can use a custom adapter bracket with a standard D-subminiature 9-pin (DB-9) connector to access these from the exterior of the unit.

Back of Zebra 4Sight XV 7

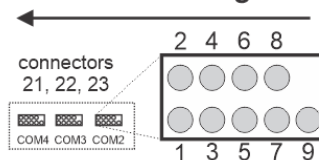

Pin	COM1	COM2, COM3, and COM4
1	MDCD-/RS422_RX+/RS485_D+	MDCD-
2	MSIN1-/RS422_RS-/RS485_D-	MSIN-
3	MSO1-/RS422_TX+	MSO-
4	MDTR1-/RS422_TX-	MDTR-
5	GND	GND
6	MDSR-	MDSR-
7	MRTS-	MRTS-
8	MCTS-	MCTS-
9	MRI-	MRI-
10	-	-

Power Supply Connectors for Peripheral Devices (System Fan)

The two system power supply connectors are 3-pin male connectors. One is connected the system fan and the other is unused.

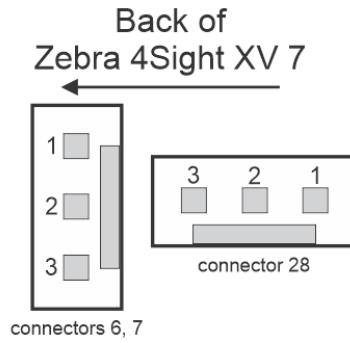

Pin	Signal
1	GND
2	PWM
3	TACH

Available Zebra 4Sight XV7 Vision Controllers

This chapter lists the available Zebra 4Sight XV7 vision controllers and the key feature changes of each SKU.

Table 1 Key features changes

SKU number	Version	Description
XV7-964W-0000-DA999-2400C	001	First shipping version of the Zebra 4Sight XV7 with i9, 64GB RAM, Win11 IoT Enterprise, full ADA license, and 24VDC power.
XV7-532W-0000-DA999-0000S	001	First shipping version of the Zebra 4Sight XV7 with i5 CPU, 32GB RAM, Win11 IoT Enterprise, full ADA license, and 600W AC power supply.
XV7-964W-0000-DA000-2400C	001	First shipping version of the Zebra 4Sight XV7, i9 CPU, 64GB RAM, Win11 IoT Enterprise, partial ADA license, and 24VDC power.
XV7-532W-0000-DA000-0000S	001	First shipping version of the Zebra 4Sight XV7, i5 CPU, 32GB RAM, Win11 IoT Enterprise, partial ADA license, and 600W AC power supply.
XV7-732L-0000-00000-0000C	001	First shipping version of the Zebra 4Sight XV7, i7 CPU, 32GB RAM, MIOS, and 600W AC power supply.

